



WIPLINE FLOATS | MODIFICATIONS | AIRCRAFT SALES
AVIONICS | INTERIORS | MAINTENANCE | PAINT



**SERVICE MANUAL AND INSTRUCTIONS FOR
CONTINUED AIRWORTHINESS
WIPLINE MODEL 10000 AMPHIBIOUS FLOATS
AT-802A FIRE BOSS CONVERSION**

Revision AJ

Wipaire | Fire Boss | Lake & Air
1700 Henry Ave – Fleming Field (KSGS), South St. Paul, MN 55075
651.451.1205 info@wipaire.com wipaire.com

THIS PAGE INTENTIONALLY LEFT BLANK

LOG OF REVISIONS

Rev	Pages	Description	Date
A-AA	All	For previous revision changes, reference Service Manual for 10000 Amphibian Floats on Air Tractor AT-802A - Fire Boss Conversion Revision AA part number 1002545.	5/10/2022
AB	15, 24-25, 103	Added note about Baldwin filter in Section 1.8 and the Inspection Checklist. Updated instructions in Shock Strut Servicing Section. Updated Shock Strut Servicing instruction step 5 and removed note.	11/3/2022
AC	23	Added note to Section 2.4.	4/6/2023
AD	7, 110	Added note to introduction about parts manual. Updated weighing procedures in Section 16.1.	7/11/2023
AE	14, 20-21, 28, 38, 92, 99, 109-110	Updated Section 1.8. Removed Section 1.15. Updated Sections 2.1 and 2.2. Added note to Section 2.8.6. Updated images in Figure 2.10. Updated Section 14.1. Updated checklist in Section 14.2. Added Section 15.3 Gear Up Landing Inspection Checklist.	1/2/2024
AF	7, 17, 20-22, 26-32, 35, 42, 44-45, 55, 76, 97-101, 103-112, 114-115	Add method of revision. Revise formatting. Update Chapter 14-16 titles. Add General Servicing, Time Limits and Maintenance Checks. Figure 2.1 was Figure 14.1. Update Figure 2.4. Update Section 2.1, 2.2, 2.3, 2.4, 2.5, 2.6, 2.7.1, 2.7.2, 2.7.5, 2.8.4, 2.8.6. Update Figure 2.11A. Add Figure 2.12 and 2.13. Add Section 14.3. Add Section 16.4 notes. Add Sections 16.5 & 16.6.	8/22/2024
AG	21, 30-31, 99, 114	Added note to section 2.2. Updated section 2.7.5. Added LPS Dry Film under General Lubricants. Changed bolt AN8-33A to AN8-32A and bolt AN7-31A to AN7-30A in section 16.4 checklist.	2/7/2025
AH	30	Updated step 2 and added note in section 2.7.5.	5/5/2025
AJ	30-31, 33, 42, 47-51, 55	Changed Cotter Pin MS26445-349 and MS26445-359 to MS24665-359 and updated step 3 in section 2.7.5. Updated Figure 2.2 schematic. Updated image in Figure 2.11A. Full rewrite of Chapter 3 for Hydraulic Pump System. Updated sections 4.5 and 4.6.	7/8/2025

View most current revision of this ICA at www.wipaire.com.

THIS PAGE INTENTIONALLY LEFT BLANK

TABLE OF CONTENTS

INTRODUCTION	7
CHAPTER 1 GENERAL INFORMATION	9
CHAPTER 2 MAIN GEAR AND NOSE GEAR OPERATION, REMOVAL AND SERVICE	19
CHAPTER 3 HYDRAULIC PUMP SYSTEM, DISASSEMBLY AND SERVICE	47
CHAPTER 4 SCOOP SYSTEM OPERATION, REMOVAL AND SERVICE	53
CHAPTER 5 FOAM DELIVERY SYSTEM OPERATION, REMOVAL AND SERVICE	61
CHAPTER 6 FLOAT BILGE SYSTEM OPERATION, REMOVAL AND SERVICE	65
CHAPTER 7 VENT AND OVERFILL PROTECTION SYSTEM	67
CHAPTER 8 FLOAT STEERING AND RETRACT SYSTEM	69
CHAPTER 9 ANGLE OF ATTACK SYSTEM	73
CHAPTER 10 AIRCRAFT WING AND CONTROL SURFACE MODIFICATIONS	75
CHAPTER 11 AUXILIARY INSTRUMENT PANEL	77
CHAPTER 12 ELECTRICAL	81
CHAPTER 13 REPAIRING FLOAT HULL SHEET METAL, BULKHEADS AND OTHER AREAS	95
CHAPTER 14 GENERAL SERVICING	97
CHAPTER 15 RESERVED	103
CHAPTER 16 TIME LIMITS & MAINTENANCE CHECKS	105
CHAPTER 17 WEIGHT AND BALANCE	117

LIST OF FIGURES

FIGURE 1.1 JACK CRADLE RECOMMENDED MODIFICATION	12
FIGURE 1.2 JACKING LOCATION.....	12
FIGURE 1.3 FLOAT SECURING LOCATIONS.....	13
FIGURE 1.4 FLOAT SECURING LOCATIONS OVERVIEW	14
FIGURE 2.1 EXAMPLE NOSE SPRING CRACK MEASUREMENTS (NOT TO SCALE).....	21
FIGURE 2.2 SCHEMATIC - HYDRAULIC SYSTEM	33
FIGURE 2.3 SCHEMATIC - ELECTRICAL SYSTEM	34
FIGURE 2.4 LAYOUT – MAIN GEAR	35
FIGURE 2.5 CARRIAGE ASSEMBLY – MAIN GEAR	36
FIGURE 2.6 ASSEMBLY – MAIN GEAR SHOCK STRUT	37
FIGURE 2.7 ASSEMBLY – MAIN GEAR ASSEMBLY	38
FIGURE 2.8 ASSEMBLY – MAIN GEAR DRAG LINK.....	39
FIGURE 2.9 ASSEMBLY – MAIN GEAR WHEEL AND BRAKE	40
FIGURE 2.10 ASSEMBLY – NOSE GEAR BOX AND RETRACTION	41
FIGURE 2.11A ASSEMBLY – NOSE GEAR LOWER END (NEW VERSION).....	42
FIGURE 2.11B ASSEMBLY – NOSE GEAR LOWER END (OLD VERSION).....	43
FIGURE 2.12 NOSE GEAR PIVOT RESISTANCE TEST.....	44
FIGURE 2.13 NOSE GEAR SPRING SIDE-TO-SIDE PLAY CHECK	45
FIGURE 4.1A ASSEMBLY – SCOOPING SYSTEM - COMPLETE	57
FIGURE 4.1B ASSEMBLY – SCOOPING SYSTEM.....	58
FIGURE 4.2A ASSEMBLY – CYLINDER PROBE JACK.....	59
FIGURE 4.2B – PROBE UP POSITION ADJUSTMENT	60
FIGURE 4.2C – PROBE DOWN POSITION ADJUSTMENT	60
FIGURE 5.1 SCHEMATIC – PLUMBING – FOAM SYSTEM.....	63
FIGURE 8.1 WATER RUDDER STEERING AND RETRACTION SYSTEM	71
FIGURE 11.1 INSTRUMENT PANEL.....	78
FIGURE 11.2 INSTRUMENT PANEL (CIRCUIT BREAKER).....	79
FIGURE 12.1 SCHEMATIC – AUXILIARY INSTRUMENT PANEL.....	83
FIGURE 12.2 SCHEMATIC – CIRCUIT BREAKER PANEL.....	84
FIGURE 12.3 SCHEMATIC – INSTALLATION – ANGLE OF ATTACK	85
FIGURE 12.4 AOA FLAP CALIBRATION READINGS	86
FIGURE 12.5 SCHEMATIC – INSTALLATION – FOAM TANKS/PUMPS	87
FIGURE 12.6 SCHEMATIC – INSTALLATION – BILGE PUMPS	88
FIGURE 12.7 SCHEMATIC – INSTALLATION – SCOOP/FILL SYSTEM	89
FIGURE 12.8 SCHEMATIC – INSTALLATION – PROBE POSITION	90
FIGURE 12.9 SCHEMATIC – INSTALLATION – PDR 60 AUDIO	91
FIGURE 12.10 SCHEMATIC – INSTALLATION – ITT / EXCESS POWER LIGHT	92
FIGURE 12.11 SCHEMATIC – INSTALLATION – WATER IN FLOAT SENSORS	93

INTRODUCTION

This service manual describes the general servicing and maintenance for the Model 10000 float when installed on the Air Tractor AT-802A aircraft; this includes the hull, landing gear, scooping systems, and other items installed with STC SA01795CH. Contact Wipaire Customer Service for services and repairs not covered by this manual.

When performing standard repairs for Wipline aluminum floats, refer to the "Structural Repair Manual for Wipline Aluminum Floats" part number 1008274. The repair manual is available online at www.wipaire.com.

Reference Wipaire document number 1011959 for a list of commercial parts applicable to STC SA01795CH.

The service products referred to throughout this manual are described by their trade name and may be purchased from the Wipaire Parts Department.

NOTE: For approved design data parts, reference the 10000 float parts manual part number 1002179.

To contact Wipaire for technical support or parts sales, call, write or email:

Wipaire, Inc.
Customer Service
1700 Henry Avenue – Fleming Field
South St. Paul, MN 55075
Phone: (651) 306-0459
Fax: (651) 306-0666
Website: www.wipaire.com
Email: customerservice@wipaire.com

When a part is significantly changed, or an additional inspection is recommended or required, a service letter and/or kit may be issued. If a warranty is issued, most commonly, it is for an 18 month time period. It is crucial to check for service letters at each periodic inspection to be eligible.

Service manuals and installation documents are revised periodically and need to be kept updated. This service manual is reissued in its entirety. The revision level, page number, and number of pages are marked on each page; revised text is indicated by a vertical black line along outer margin. The most current revision of service letters, service kits, and service manuals are maintained and distributed online at www.wipaire.com.

NOTE: It is critical to check for manual updates each time an inspection is executed.

THIS PAGE INTENTIONALLY LEFT BLANK

CHAPTER 1 GENERAL INFORMATION

CONTENTS

1.1 AIRPLANE	10
1.2 FLOATS	10
1.3 TOWING	11
1.4 HOISTING	11
1.5 LEVELING	12
1.6 JACKING PROCEDURES	12
1.7 JACK REMOVAL.....	14
1.8 AMPHIBIAN LANDING GEAR SYSTEM.....	14
1.8.1 LANDING GEAR HANDLE.....	15
1.8.2 INDICATOR LIGHTS	15
1.8.3 LANDING GEAR OPERATION.....	15
1.8.4 EMERGENCY PUMP HANDLE	16
1.9 SCOOP SYSTEM	16
1.10 FOAM SYSTEM.....	16
1.11 VENT AND OVERFLOW PROTECTION.....	17
1.12 HARD AND OVERGROSS LANDING AND DAMAGE INVESTIGATION.....	17
1.13 CLEANING	18
1.14 CORROSION	18

CHAPTER 1 - GENERAL

1.1 AIRPLANE

The airframe of the Fire Boss is adapted from the Air Tractor AT-802A agricultural airplane. It is an all-metal, low cantilever wing design. It is powered by a Pratt and Whitney PT6A-67AG turboprop engine of 1350 SHP or PT6A-67F of 1600 SHP. The airframe is detailed in Air Tractor publications.

To create this fire suppression version of the airplane, a number of changes to the landplane were incorporated:

1. Amphibious floats with hydraulically actuated water scoops are installed.
2. The Air Tractor Fire Retardant Delivery System (FRDS) is utilized.
3. The Air Tractor foam system and controls are utilized.
4. Additional foam tanks in the floats supplement the standard firewall tank.
5. Changes to the hopper venting system are incorporated.
6. A new upper instrument panel is added to contain some of the scoop related and system controls and indicators.
7. A bilge pumping system and a water in floats warning system are incorporated.

These changes will be briefly discussed in the following paragraphs.

1.2 FLOATS

The model 10000 amphibious float is an all aluminum constructed float with (12) watertight compartments of approximately 10,000 pounds buoyancy. As a part of the float installation, the following additional changes are made to the landplane:

1. The hydraulic landing gear retraction system components and cockpit controls are added.
2. The cockpit landing gear controls and emergency hand pump and system are added.
3. The float water rudder retraction system and cockpit controls are added. The water rudders are locked center when retracted for improved directional stability.
4. A ventral fin is added for improved directional stability.
5. Two auxiliary finlets are added to each side of the horizontal stabilizer for improved directional stability. Four total per aircraft.
6. The vertical fin is sealed to the fuselage/stabilizer top for improved directional stability.
7. The open fuselage structure near the landplane tail-wheel mount is faired over for improved directional stability.

8. Pump-out cups on float top deck are placed between each float watertight compartment to pump out any water in floats before flight.
9. Vortex generators are added to the wing upper surface leading edges for improved longitudinal controllability.
10. Vortex generators are added to the horizontal stabilizer upper surface leading edges for improved longitudinal controllability and stall speed reduction.
11. The elevator trim/servo tabs incorporate a 1-inch chord extension for improved longitudinal controllability.
12. Access to the float interior is accomplished by removing covers on the top deck and six covers inside the wheel well. When necessary, water inside the float hulls may be removed through pump-out cups located on the outboard edge of each float top skin.

1.3 TOWING

When towing the amphibian aircraft, 2 lugs are provided on the lower forward side of the nose spring.

On land, a rigid "V" frame can be fabricated to attach to these lugs for towing the aircraft with a tractor. Lake & Air Training and Pilot Shop has this tow bar available for purchase.



On water, a rope bridle arrangement can be used to tow the aircraft from the lugs described above.

1.4 HOISTING

Hoisting the aircraft can be performed using a lifting rig that attaches to the aircraft with lifting rings that are installed at the wing attach points. If the lifting rings are not installed, reference applicable aircraft maintenance/service manual for additional hoisting specifications. Lake & Air Training and Pilot Shop has this hoisting rig available for purchase. Contact Wipaire Customer Service for additional guidance in removal or installation of floats.

CAUTION!

Make sure nothing is under or above the airplane or floats when hoisting the aircraft.

1. Raise aircraft high enough to place float cradle under floats as shown in Figure 1.4.
2. Lower aircraft onto float cradle as shown in Figure 1.4.
3. Place fore and aft supports as shown in Figures 1.3 and 1.4.

1.5 LEVELING

See applicable aircraft maintenance/service manual.

1.6 JACKING PROCEDURES

CAUTION!

Make sure nothing is under or above the airplane or floats when jacking the aircraft.

1. Turn off fuel.
2. Place weighted bags above the nose gear (approximately 100 lbs. on each float to start, more may be added as needed).
3. Position 1 person at each fore and aft of each float, and 3 people at the jacking location of one float.
4. Modify jack saddle of a 3 ton minimum jack by welding as shown in Figure 1.1.

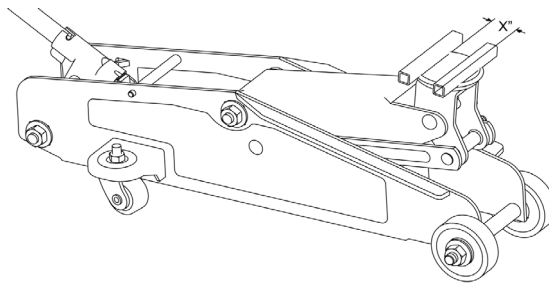

(X = WIDTH OF CRADLE)

FIGURE 1.1 JACK CRADLE RECOMMENDED MODIFICATION

NOTE: This is not required and Wipaire does not have the parts for modification. It is recommended a similar modification be performed to the jack saddle to prevent the slippage of the cradle.

1. Center cradle on saddle and position so cradle is as far aft on the main keel as possible without interfering with main gear as it decompresses as shown in Figure 1.2.

NOTE: If desired to prevent possible cosmetic damage to float, use material to separate cradle and float.



FIGURE 1.2 JACKING LOCATION

1. Jack one side at a time, taking care to check the balance of the aircraft and adding more weight to the front if needed.
2. Two people, both outboard, lift the fore and aft cradle stands up to the cradle as a 3rd person release the pressure slowly, allowing the cradle and stands to gently contact the ground.
3. Repeat previous procedure to the other float.

NOTE: A smaller jack may be needed to slightly lift the float into a high enough position for the main jack.

4. Secure floats with fore and aft supports as shown in Figures 1.3 and 1.4.



FIGURE 1.3 FLOAT SECURING LOCATIONS



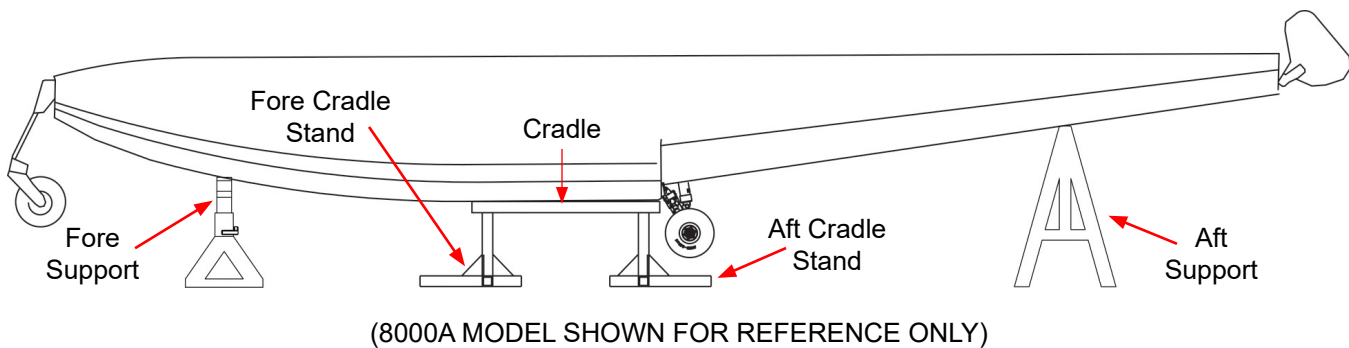

FIGURE 1.4 FLOAT SECURING LOCATIONS OVERVIEW

1.7 JACK REMOVAL

CAUTION!

Make sure nothing is under or above the airplane or floats when removing the jacks from the aircraft.

1. Turn off fuel.
2. Verify landing gear is in the down and locked position.
3. Verify weighted bags are still located above the nose gear.
4. Position 1 person at each fore and aft of each float, and 1 person at the jacking location of one float.
5. Remove all fore and aft supports as shown in Figures 1.3 and 1.4.
6. Using modified jack saddle as shown in Figure 1.1, center jack saddle in center of cradle on 1 of the floats,
7. Lift aircraft to clear fore and aft cradle stands and remove fore and aft cradle stands of lifted float.
8. Slowly lower float to the ground, remove jack from under float, and remove cradle from jack saddle.
9. Repeat previous procedure to the other float.
10. Remove weighted bags from floats.

1.8 AMPHIBIAN LANDING GEAR SYSTEM

The landing gear incorporated within the amphibious floats on this airplane is retractable, quadricycle type with two swiveling nose (or bow) wheels and four (4) (two (2) sets of dual) main wheels. Air-oil shock struts on the two main landing gear assemblies provide shock absorption.

The main landing gear on each float has dual 8:50 x 10 8-ply tires and the nose landing gear has one 6:00 x 6 8-ply tire. The gear system is hydraulically actuated and driven by two hydraulic pumps. Brakes are hydraulic and have a caliper on each main wheel for a total of four brakes. The float break system ties into the aircraft brake system.

Steering on land is accomplished by differential braking. The nose wheels are full castering.

Landing gear extension and retraction is accomplished by two (2) electrically-driven hydraulic pumps and four (4) hydraulic actuators (one (1) for each gear). The hydraulic pumps are located in fuselage aft of cockpit and the hydraulic actuators are located adjacent to each gear. Hydraulic system fluid level should be checked periodically by viewing the sight glass for fluid level in the upper one-third of the range with the hydraulic system pressurized. If fluid is low, fill with MIL-H-5606 or equivalent.

Per Service Letter 103, a spin-on type filter assembly with a Baldwin filter has been incorporated to facilitate additional filtering of the hydraulic system. Replace Baldwin filter if pop out gage (if equipped) has been released indicating bypass has been activated due to clogged filter or at time of annual inspection.

Landing gear operation is initiated by movement of the landing gear handle. When the handle is repositioned, hydraulic pressure in the system will drop and pressure switches will automatically turn on the hydraulic pump motors to maintain operating pressure in the system. When the gear cycle is completed, the pump will automatically shut off. If the pressure in the system drops to a preset value, the pressure switches turn the pump motors back on and build up the pressure to the limit again. Eight (8) position-indicator lights four (4) gear UP and four (4) gear DOWN are provided to show landing gear position. Two (2) additional indicator lights show when the landing gear pump motors are operating.

1.8.1 LANDING GEAR HANDLE

The landing gear handle controls a hydraulic selector valve within the control unit on the left-hand side of cockpit by fuel shut-off handle and has two (2) positions (UP and DOWN LAND) which give a mechanical indication of the gear position selected. From either position, the handle must be pulled out to clear a detent before it can be repositioned.

1.8.2 INDICATOR LIGHTS

Ten (10) indicator lights are mounted on the landing gear control unit adjacent to the landing gear handle. Four (4) blue indicator lights, labeled NOSE and MAIN (left-hand lights for the left float and right-hand lights for the right float), show by their illumination that the landing gear is up and locked. The four (4) green indicator lights, labeled NOSE and MAIN (left-hand lights for the left float and right-hand lights for the right float), are illuminated when the landing gear is down and locked. Neither set of lights is illuminated when the landing gear is in transit. Two (2) red indicator lights, labeled PUMP ON 1 and 2 illuminate when current is supplied to the landing gear motors.

If the motors continue running during flight or on and off repeatedly, the motors should be shut off by pulling AMPHIBIAN PUMP 1 AND AMPHIBIAN PUMP 2 circuit breakers. Continual running of the motors can result in premature motor failure. Prior to landing, the circuit breakers should be pushed in to reactivate the circuits. Troubleshoot hydraulic problem per Section 3.1.

1.8.3 LANDING GEAR OPERATION

To retract or extend the landing gear, pull out on the landing gear handle and move it to the desired position. When the handle is positioned, pressure on the hydraulic system reduces to where the hydraulic motors automatically turn on.

The motors power the hydraulic pumps and actuate the gear actuator for each gear. During operation of the landing gear motors the PUMP ON 1 and 2 indicator lights are illuminated. When the gear cycle is completed, pressure builds up in the hydraulic system and automatically shuts off the hydraulic motors. Each gear operates independently of the other, and therefore, the position lights illuminate at various times.

1.8.4 EMERGENCY PUMP HANDLE

An emergency hand pump is located on the floor to the left side of the seat for use in the event the normal hydraulic system fails. This hand pump may be used to retract or extend the land gear. Prior to utilizing the emergency hand pump, pull the AMPHIB PUMP 1 and 2 circuit breakers to deactivate the electric hydraulic pumps. Select UP and DOWN using the normal landing gear selector handle. Pump the attached handle back and forth (approximately 400 cycles). When a gear reaches the selected position, its indicator light will illuminate. After all four (4) gears are in the selected position there is a noted increase in resistance of hand pump operation.

1.9 SCOOP SYSTEM

The Wipaire 802 Fire Boss has two water scoops, one in each float. The scoops are three inches in diameter and are hydraulically operated by the 1000 psi float hydraulic system. The hydraulic system has an accumulator to enhance the speed of scoop deployment and retraction. The scoops complete down or up cycle in approximately one second. A trigger switch located on the front of the control stick grip controls the scoops. Pulling in the top of the trigger switch puts the scoops down. Releasing the trigger switch puts the scoops back up (pulling on the bottom of the trigger switch operates the smoke system; see Air Tractor Flight Manual).

The scoop system master switch is located on the glare shield panel and has three positions, auto, off, and manual. When manual is selected, the scoops move to the down position and remain there as long as the trigger switch is depressed; when the trigger switch is released, the probes move back to the up/stowed position.

CAUTION!

In the manual position, it is possible to overflow the hopper.

When auto is selected, the pilot may select how many gallons he wants to scoop by rotating the fill level selector knob located to the right side of the hopper quantity and fill level readout window (hopper quantity is on the top reading and the selected fill level is on the bottom).

When the quantity reads approximately 255 gallons the hopper empty (the scale starts at that number) with auto selected, the scoops will go down when the rocker switch is depressed and move back up automatically when the quantity selected is reached (with the rocker switch still depressed). If the rocker switch is released before the quantity is reached, the scoops will move back up.

If the pilot wants to abort the scoop operation once it is initiated, simply releasing the rocker switch will put the scoops back up, such as in an emergency or other unplanned occurrence. Scoop up and scoop down lights are provided that indicate scoop position via a pressure switch that illuminates the lights. The scoop lights (2) can be tested utilizing the test switch on the left side of the glare shield panel.

1.10 FOAM SYSTEM

The Wipaire 802A Fire Boss foam system consists of three individual tanks. The original 18-gallon firewall tank is supplemented by an additional 30 U.S. gallon tank in each float (at sta +1) of which approximately 28 U.S. gallons is usable in the automatic mode. In the manual mode all 30 gallons are usable. A total of approximately 74 U. S. gallons can be delivered to the hopper (in the automatic mode) utilizing the foam control panel located on the left side of the cockpit just below the fire gate computer. In the manual mode, a total of 78 gallons can be delivered to the hopper. The float tanks are optional and one or both can be removed depending on the type of operation. (Tank and floor 50 lbs at +1.0 each float)

To use fluid stored in the float tanks, it is necessary to pump fluid from the float tank to the fuselage firewall tank. This transfer can be accomplished manually or automatically by selecting the appropriate position with the left and right foam control switches located on the glare shield panel. When manual "on" is selected, fluid will be pumped via the electric pump located on the top of the tank to the firewall tank.

The pump does not shut off when the tank is full. In the event of an over flow, fluid would come out of the firewall tank vent fitting located just aft of the front left float strut.

When auto is selected, the float tank transfer pump will come on at approximately 7 gallons of fluid remaining in the fuselage tank. It will shut off automatically when the fuselage tank is approximately 2/3 full or whenever the selected float tank has about 2 gallons remaining.

The left and right transfer systems can be used individually or simultaneously as desired. Whenever a foam transfer pump is operating, the appropriate green Pump On light will illuminate (manual or auto). The Pump On lights can be tested utilizing the test switch on the left side of the glare shield panel.

1.11 VENT AND OVERFLOW PROTECTION

The original 802-hopper vent/door has been modified to allow for a greater venting volume during scooping operations. The original 3-inch Air Tractor vent located on the aft right side of the fire gate is supplemented with the addition of a 5-inch vent that exits at the right aft side of the rear fire gate fairing. In the event of an overflow during scoop operations, a spring loaded relief valve door is located directly aft of the main drop vent door. Water will exit the hopper to the right and forward of the cockpit windshield. The pilot can see ahead out of the left side of the windshield during an overflow condition.

The door spring needs approximately 40 pounds of pressure to open. To check this, use a hand held spring type scale. Locate scale to the center of door on outside edge.

NOTE: Before opening the main vent door for access, the door bracing turnbuckles (located inside the hopper just below the vent door) need to be disconnected. They are accessible with the drop vent door open (1 on each side).

1.12 HARD AND OVERGROSS LANDING AND DAMAGE INVESTIGATION

After a thorough cleaning of the suspected damaged area, all structural parts should be carefully examined to determine the extent of damage. Frequently the force causing the initial damage is transmitted from one member to the next causing strains and distortions. Abnormal stresses incurred by shock or impact forces on a rib, bulkhead or similar structure may be transmitted to the extremity of the structural member, resulting in secondary damage, such as sheared or stretched rivets, elongated bolt holes or wrinkled skins or bulkheads.

Points of attachment should be examined carefully for distortion and security of fastenings in the primary and secondary damaged areas at locations beyond the local damage. A checklist in the Time Limits and Maintenance Checks Chapter of this manual provides the details on areas requiring inspection when aircraft is suspected of exceeding its published landing weight.

1.13 CLEANING

The outside of the float should be kept clean by washing with soap and water. Special care should be taken to remove engine exhaust trails, waterline marks, and barnacle deposits. After saltwater operation, washing with fresh water should be done daily with special attention to hard-to-reach places such as: seams, wheel well, etc.

Alternatively, water taxiing in FRESH WATER at step-speed with the water scoops in the DOWN position and the fire gates OPEN can help to flush the entire system. This method is especially recommended as a daily cleaning for operators scooping in saltwater.

NOTE: Operators scooping saltwater are strongly cautioned – rinsing the entire aircraft & floats with fresh water inside and outside at the end of each day is critical. Failing in this cleaning will severely shorten the life of the floats.

The float interior should be flushed if saltwater enters the compartments. If the floats are being stored inside, remove inspection covers so the interior will dry out.

NOTE: The above cleaning techniques are vital for keeping corrosion to a minimum. Saltwater operations and environment are strongly linked to corrosion and must be addressed proactively.

1.14 CORROSION

Reference the Wipaire Structural Repair Manual (SRM) for allowable corrosion/material loss limits. Corrosion is a reaction that destroys metal by an electrochemical action that converts metal to oxide. Corrosion is accelerated when in contact with dissimilar metals such as aluminum and steel, or any material that absorbs moisture like wood, rubber, or dirt.

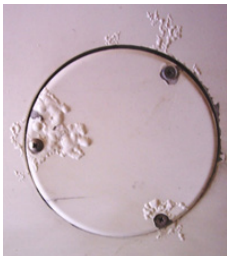

The primary means of detection of corrosion is visual. The most obvious sign is a corrosive deposit of white powder. Other signs are discoloration of the metal surface or bubbles and blisters under the painted surface. Light corrosion may be removed by light hand sanding or chromic acid. Moderate and severe corrosion (blistering, flaking, and pitting) may be removed by heavy sanding or grinding, and applying chromic acid. If significant loss of skin material thickness will result after corrosion treatment, reinforcement or replacement of the affected area may be necessary.

After removing the corroded area, restore area to original finish (prime and enamel). BOESHIELD T9, Corrosion X, or ACF-50 may also be applied to stop corrosion. Refer to manufacturer's instructions for application instructions.

Maintaining the float inside and outside finishes by washing after saltwater operations will help protect the float from corrosion. Periodically all hardware should be covered with a waterproof grease or Paralketone. Under saltwater conditions, bolts should be removed at least once a year and grease reapplied to the shafts, heads and nuts.

NOTE: The above cleaning techniques are vital for keeping corrosion to a minimum. Saltwater operations and environment are strongly linked to corrosion and must be addressed proactively.

CHAPTER 2 MAIN GEAR AND NOSE GEAR OPERATION, REMOVAL AND SERVICE

CONTENTS

2.1 DESCRIPTION AND OPERATION.....	20
2.2 SERVICE – NOSE GEAR	20
2.3 NOSE BOX TRACK WEAR.....	21
2.4 SERVICE – MAIN WHEELS AND BRAKES	21
2.5 SERVICE – MAIN GEAR OLEO	22
2.6 SERVICE NOSE AND MAIN GEAR RAMS	26
2.7 ADJUSTMENT/TEST.....	26
2.7.1 NOSE GEAR ACTUATION AND INDICATION	26
2.7.2 MAIN GEAR ACTUATION AND INDICATION	27
2.7.3 BLEEDING HYDRAULIC SYSTEM AFTER SERVICE	29
2.7.4 HYDRAULIC ACCUMULATOR SERVICE	30
2.7.5 NOSE GEAR AXLE AND PIVOT ADJUSTMENT / SHIMMY CORRECTION.....	30
2.8 MAIN AND NOSE GEAR REMOVAL AND DISASSEMBLY.....	31
2.8.1 REMOVAL OF MAIN GEAR OLEO	31
2.8.2 REMOVAL OF MAIN GEAR RETRACTION CYLINDER.....	31
2.8.3 REMOVAL OF MAIN GEAR DRAG LINK.....	31
2.8.4 REMOVAL OF NOSE GEAR TROLLEY FROM NOSE BOX.....	32
2.8.5 REMOVAL OF NOSE GEAR BOX.....	32
2.8.6 REMOVAL OF LOWER NOSE GEAR FROM PIVOT BLOCK.....	32
2.8.7 TO REMOVE THE NOSE GEAR	32

CHAPTER 2 - MAIN GEAR AND NOSE GEAR OPERATION, REMOVAL AND SERVICE

2.1 DESCRIPTION AND OPERATION

Retraction and extension of the main and nose landing gear is effected by a hydraulic actuation system shown schematically in Figure 2.2. The landing gear is driven by two hydraulic pumps located at fuselage station 159.5.

A pressure of between 525 and 1250 psi is maintained in the supply line. When the pressure falls below 525 psi, the pressure switch activates the pump solenoid, providing power to the pump. When the pressure reaches 1150-1250 psi, the pressure switch deactivates the solenoid and the pump motor stops. Figure 2.3 shows the electrical schematic of the system. A check valve on the output side of the pump retains pressure in the system while the pump is off. The pump has an internal relief valve, which directs oil back to the pump reservoir when the line pressure exceeds 1450 psi. The system also has an internal relief valve to protect against thermal expansion when line pressure exceeds 2000 psi.

A cockpit mounted control valve accomplishes the selection of gear up or gear down. Each float gear has individual indicator lights on the control valve allowing the pilot to confirm that each gear has fully retracted or extended. An emergency hand pump is provided, in case of total electric pump failure, or loss of fluid. The reservoir has additional hydraulic fluid, available only to the hand pump.

The main gear is mechanically locked in both up and down positions. Locking and unlocking is effected utilizing a small amount of lost motion of the actuator rod. Retraction takes place when pressure is exerted on the actuator piston driving the collar along the slide tube. The lock is tripped when the follower slides up the contoured track in the actuator as shown in Figure 2.5. A reverse process affects extension. Gear position light proximity switches are closed when the appropriate hook (containing the magnetic material) nests over the locking bar.

Shock absorption for the main landing gear is provided by a hydraulically dampened air spring. Figure 2.6 shows the main components. The oil and air share a common chamber. When the oleo is collapsed, the oil is forced through the main orifice, compressing the air in the upper cylinder. Extension reverses this process. The extended oleo is initially set at the factory to 250 psi no load. In-field adjustment of air pressure and oil volume is described in Section 2.2

The nose gear has an over-center down lock. Retraction occurs when pressure is applied to the forward face of the actuator piston and the carriage is drawn along the tracks in the nose box as shown in Figure 2.10. Gear position light proximity switches are closed when the piston containing the magnetic material has reached either end of its travel.

The nose gear consists of composite fiberglass beams that are attached at the bottom to casting blocks. Inside the block is a casting pin that is set into the machined fork assembly. The casting pin allows the nose wheel to pivot in a complete circle. The geometry is such that no shimmy dampers are necessary. A spring loaded ball rides in a groove machined in the casting pin. This groove has a round pocket on the back face with the result that the cam provides retention of the pin within the block and self-centering of the wheel. The casting pin and block interface with an upper sleeve bearing and a lower tapered roller bearing. A previous design utilized two spherical plain bearings.

2.2 SERVICE – NOSE GEAR

The nose gear pivot assembly should be cleaned and greased per the checklist in Section 16.1 or more frequently whenever in water for extended period of time. Nose gear tracks to be lightly greased. Apply grease to a cloth on a stick or rod and run along tracks inside of the nose box, both sides.

The nose gear springs should be inspected per the checklist in Section 16.1. If cracks extend lower than upper plate P/N 13A07212-002, remove spring and inspect holes. Replace nose spring if any one crack exceeds 1.5 inches or if any two cracks originating at one hole exceed 1.25 inches in total length as shown by Figure 2.1.

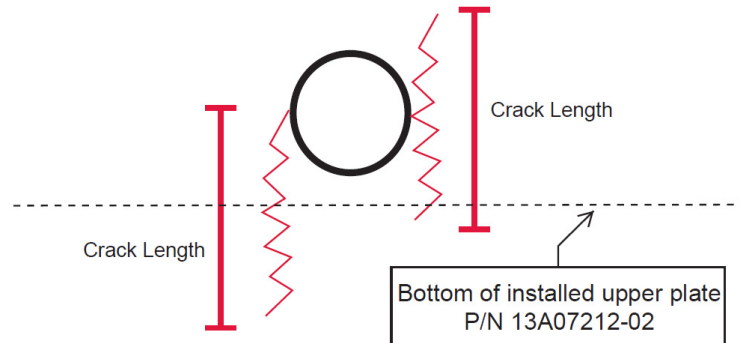

FIGURE 2.1 EXAMPLE NOSE SPRING CRACK MEASUREMENTS (NOT TO SCALE)

The nose gear pivot bearings are serviced with by zerk fittings. An EP-rated, lithium-based grease containing molybdenum disulfide (MoS₂) additives is highly recommended. See Section 14.2 for recommended lubricants.

NOTE: Earlier pivot block designs placarded for "Green Grease" may be serviced accordingly.

Pivot bearings may be replaced on condition. Note that the press fit of the bronze sleeve bushing (when equipped) can affect its inner diameter upon installation, and may therefore require honing or reaming to a diameter of 1.250 +/- 0.001" for proper clearance with the pivot pin.

The nose wheels contain grease zerks for the wheel bearings. They should be greased per the checklist in Section 16.1 or more frequently whenever in water for an extended period of time.

Nose tires are standard 6:00 x 6, 8-ply, inflated to 50 +/- 5 psi.

2.3 NOSE BOX TRACK WEAR

Due to the wear the roller/slide block places on the track as the gear are retracted, the block needs to be measured for the amount of wear. The tolerance for wear is 0.050 inches. If the wear is, or is less than the limit, it can still be used. If the wear in the track is greater than 0.050 inches, the track must be replaced. This check is to be done every annual inspection and is part of the maintenance checklist. (Reference Gear Track P/N 13A07104-001 LT, 13A07104-002 RT)

2.4 SERVICE – MAIN WHEELS AND BRAKES

Grease nipples are provided on all wheels and bearings and should be greased every 25 hours or after an extended period of time in the water. Water/heat resistant grease is recommended.

NOTE: If replacing any of the (2) bushings located within the drag brace or the (2) within the axle assembly, the internal grooves must be aligned to the zerk fitting and a grease hole must be drilled into the bushing after insertion. These are the "bearings" identified in Figure 2.8.

The dual piston brakes need no special care other than to maintain the brake disc free of rust, which causes premature brake lining wear. Bleeding is carried out from the bottom up. Since the line is "T"ed to the double brake, one must remember to bleed one segment first, then finish bleeding through the remaining segment.

At brake installation, apply CRC1003791 synthetic brake and caliper grease or equivalent to brake caliper pins.

Main wheel tires are standard 8:50 x 10, 8-ply type III aircraft tires, inflated to 50 +/- 5 psi. (Refer to Figure 2.9).

2.5 SERVICE – MAIN GEAR OLEO

WARNING!!

Release air pressure and remove air valve before attempting to service oleo. After filling, refit valve and cap, then pressurize to 250 psi.

Oil Level – The correct level is best set by draining and refilling with the correct quantity of fluid (1900 ml). This should be done with the oleo removed from the float.

Air Pressure – The correct air pressure is 250 psi (+/-10 psi) on a fully extended oleo (no load) or it can be inflated to approximately 3-4 inches on an unloaded aircraft while sitting static on level ground.

Seals – Seals should be replaced whenever the oleo is disassembled or leaking. The seals are standard “O” rings whose part numbers are depicted in Figure 2.6.

NOTE: Use only MIL-H-5606 fluid.

NOTE: When reinstalling the main gear oleo bolts, tighten so oleo is free to rotate.

Shock Strut Servicing

WARNING!!

Release pressure in strut before disassembly.

1. Disassemble the strut, removing both end caps. Take apart the gland section and metering tube so the parts can be easily inspected for wear and replacement parts can be installed as needed.



2. Inspect all parts carefully after cleaning for wear and scoring, especially the piston, gland section, and the inside of the outer cylinder. Also make sure to check the bushings in the end-caps for wear and security.

3. The metering tube does not need to be taken apart from the end-cap of the inside cylinder unless extensive cleaning is desired. If it is disassembled:
 - a. To return the metering tube height and condition to factory preset, first apply blue Loctite to the threads of the inner end-cap threads that hold the metering tube for added security until next removal.
 - b. The metering tube is threaded until the measurement from the floor of the inside of the end-cap to the end of the inserted metering tube is 13.875 inches.
 - c. Tighten the associated jam nut at that end and stake it for added security.
 - d. Set this metering tube assembly aside and move on to next steps.

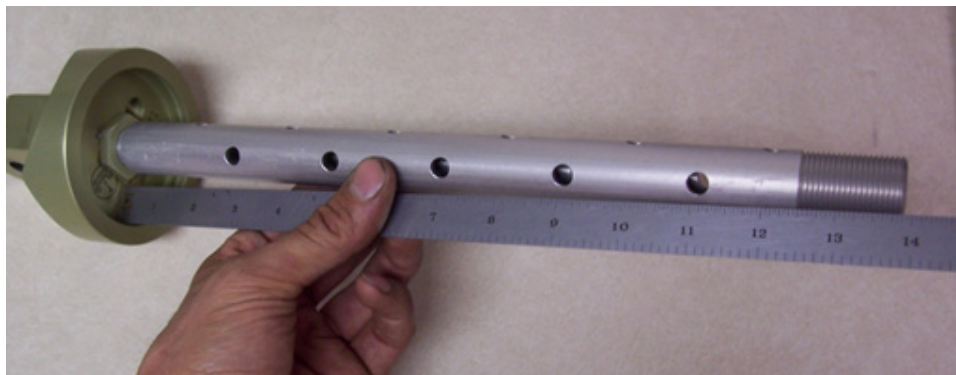

4. On the other end, install the metering tube with Loctite onto the end-cap and tighten to approx. 30 ft./lbs.
5. Install outer T-seal to end-cap with Vaseline. Install inner cylinder into top end cap with PR-1422.



6. Install the end-cap bolts with gasket sealer on the threads for added security. Tighten to 25-30 in./lbs. making sure not to over-tighten, damaging the T-seal. Set this part of the unit aside and move on to next steps.



7. To assemble the gland assembly, insert the inside T-seal and wiper, again using Vaseline on the T-seal.
 - a. The gland must be installed from the end-cap side (this is the side without the holes).
 - b. Lube the outside of the inner cylinder with hydraulic fluid for ease of assembly.
 - c. Install the T-seal into the end-cap, again using Vaseline for lube.
 - d. Install the inner cylinder into the end-cap (the end of the tube without holes).

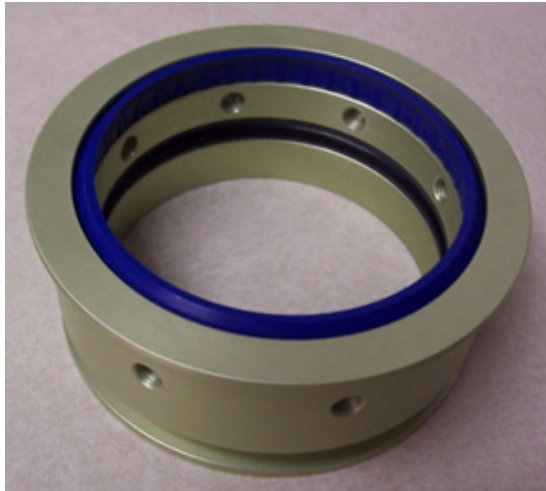

8. For piston install, place the piston onto the metering tube using hydraulic fluid for lube to prevent damage to the threads.
 - e. Using a spanner wrench, tighten the piston to the inner cylinder.
 - f. Install the jam nut onto the piston end of the metering tube and stake for security.
 - g. Install the 2 T-seals onto the exterior of the piston and gland, and lube with Vaseline.



9. Gently clamp the outer tube end in a vise and add 1900 ml of hydraulic fluid (MIL-H-5606 or equivalent).
10. Lube the inside of the outer cylinder where the gland and the piston will rest.
11. Install the inner cylinder into the outer assembly, making sure that the gland is seated against the piston.



12. Re-install the center bolts using gasket sealer.



13. Install the O-ring onto the fill/drain plug before installing the plug onto the end-cap.



14. Install the O-ring onto the Schrader valve and install onto the outside of the end-cap.

NOTE: Align Schrader valve 180 degrees from the placard.

NOTE: Double check the plugs and bolts for proper installation and security before adding gas charge.

15. Fill the strut with nitrogen to 250 psi +/- 10 psi and close the valve and cap.



2.6 SERVICE NOSE AND MAIN GEAR RAMS

Lubricate the nose and main gear cylinder mounting flanges with MIL-H-5606 hydraulic fluid through the oilers. The nose has a flip-lip type oiler and the mains have a ball-needle type oiler. The purpose is to wet the felt wiper so it pre-lubes the penetration rams and enables the seals inside to work and not become damaged over time.

The service intervals on the Main Gear Actuators should be every 25 hours if the aircraft is regularly taxiing on sand and gravel. Otherwise they should be cleaned and serviced according to the checklists from the back of this manual. Clean the slide tube with clean solvent to remove any build up of dry or dirty lubricants. Inspect the slide tube for erosion and/or nicks and protrusions caused by gravel or debris being thrown by the Main Landing Gear tires. Grease the actuator mechanism with HCF grease, P/N 605, or equivalent and wipe the slide tube down with a clean rag soaked in lubricant.

2.7 ADJUSTMENT/TEST

2.7.1 NOSE GEAR ACTUATION AND INDICATION

Adjustment of actuator stroke is provided at the ends of the piston rods.

The length of the nose gear rod is adjusted such that the over-center knuckle (brass) rollers just bottom out on the down side and the piston just bottoms out on the mounting flange at the same time.

The up stops nests in the up-stop bolt. See Figures 2.9 and 2.10 for locations and assembly.

Nose gear proximity switches are located on clips that are mounted on the outer cylinder body, one on each end. The most forward switch is for the gear down lights and most aft is for the gear up position lights. Set the proximity switch mounting clip along outer cylinder body to a position such that the light goes out when the over-center track is about 1/4 inch from bottomed position while traveling in the up direction. Lights should come on about 1/8 inch from the bottomed position while traveling in the down direction.

The cylinder piston has a magnet that will activate the proximity switches.

Nose spring side-to-side play can be adjusted via the stop/retaining rods which pass through the nose gear end tracks. See Figures 2.10 and 2.13. With nose gear extended and aircraft on jacks, the bottom of the nose spring should have a total side-to-side travel of 1/8"-1/4" (ensure aircraft shifting does not influence check). Verify smooth retraction/extension of the nose gear after adjustment. Hydraulic pump cycling may indicate restricted motion.

2.7.2 MAIN GEAR ACTUATION AND INDICATION

The main gear actuator cylinder is not adjustable. These are pre-set at the factory to ensure that the main gear is locked at the end of each stroke and that correct indication is given on the cockpit console.

The up and down lock may be adjusted so the lock is fully engaged by adjusting the set screws shown in Figure 2.5. A detailed procedure is provided below. The main gear proximity switches are located on each end of the gear stroke. The forward switch is located on the forward side of the gear tunnel. It is accessible through the top deck access cover. The aft proximity switch is located on the float bulkhead just aft of the wheel well, accessible through the float top deck cover.

The main gear proximity switches are adjusted loosening the mounting screws and positioning them as such that the light goes out when the lock hook is raised about 1/8 inch off its nested position and comes on again upon nesting. Troubleshooting related to main gear position indication is included within the procedure below.

PROCEDURE – MAIN GEAR LATCH RIGGING AND POSITION INDICATOR TROUBLESHOOTING:

NOTES:

- The following instructions will require 2 or more people to complete.
 - Refer to main gear and main gear carriage figures – 2.4 and 2.5 – throughout this procedure.
 - As configured from the factory, the forward catch pin block (6A05193-001) is spaced from the forward tunnel fitting with (2) NAS1149F0463P washers per bolt location while the aft catch pin block is spaced from the aft tunnel fitting with (1) NAS1149F0463P washer per bolt location. This is the recommended baseline configuration, to be checked and adjusted as needed in the course of the procedure below.
1. Jack aircraft.
 2. Remove the top deck access cover just aft of the baggage compartment.
 3. Remove the main gear tunnel access cover.
 4. Retract the gear as follows:

NOTE: The following can be done with the emergency hydraulic hand pump. If choosing to hand pump the gear to the “UP” position, pull the Hydraulic Pump 1 and Pump 2 Circuit Breakers before turning the master switch “ON”. Using hand pump will take about 400 strokes.

- a. Verify gear selector is in the “DOWN” position.
 - b. Turn the master switch to the “ON” position.
 - c. Select “UP” on the gear selector.
 - d. When the main gear carriage is a couple inches forward of the DOWN lock position, pull the hydraulic “PUMP 1” and “PUMP 2” circuit breakers to stop the gear actuation.
 - e. Disconnect the top oleo strut attach bolt from the main gear carriage assembly. Refer to Figure 2.5.
 - f. Push in the hydraulic “PUMP 1” and “PUMP 2” circuit breakers so that the main gear carriage continues to the UP position.
 - g. When gear is in the full UP position, pull the Hydraulic “PUMP 1” and “PUMP 2” Circuit Breakers.
 - h. Turn the master switch to the “OFF” position.
5. Inspect the main gear carriage assembly as follows (all checks are completed through the main gear tunnel access hole):

NOTE: The following is done with the emergency hydraulic hand pump

- a. Select "DOWN" on the gear selector.
- b. Extend the emergency hydraulic hand pump handle.
- c. Pump the emergency hydraulic hand pump until the main gear carriage is clear of the UP lock.
- d. Remove the main gear carriage cover.
- e. Verify that the UP and DOWN latches (aka lock hooks) move freely.
 - i. If the UP and DOWN latches are stiff and/or stuck in position, it is likely that the AN6 pivot bolt and/or AN3 top spring retainer bolt are over-torqued. Torque the AN6 and AN3 bolts so that the UP and DOWN latches can move freely.
 - ii. If the UP and DOWN latches remain stiff, the slide tube and main gear carriage should be removed and the main gear carriage should be inspected for corrosion or other damage.
- f. By hand, slide the main gear carriage forward and aft on the hydraulic ram shaft to check the "lost motion". The lost motion is approximately 1 inch of travel. While checking the lost motion the UP and DOWN latches should be moving up and down freely. If the lost motion is not smooth or non-existent, the slide tube and main gear carriage should be removed and the carriage should be inspected for corrosion or other damage.

6. Inspect the main gear carriage assembly rigging as follows:

NOTE: The following is done with the emergency hydraulic hand pump, following the procedures described above.

- a. Move the gear to the full "UP" and locked position.
- b. Verify that the UP latch is fully engaged onto the lock pin. The UP latch should be resting flat on the top surface of the main gear carriage.
- c. Select "DOWN" on the gear selector and pump gear slowly while verifying that the UP latch just clears the lock pin.
- d. If either b or c are out of tolerance, perform step 7 for this latch at this time. Once these checks are good, proceed to the next step.
- e. Move the gear in the full "DOWN" and locked position.
- f. Verify that the DOWN latch is fully engaged onto the lock pin. The DOWN latch should be resting flat on the top surface of the main gear carriage.
- g. Select "UP" on the gear selector and pump gear slowly while verifying that the DOWN latch just clears the lock pin.
- h. If either f or g are out of tolerance, perform step 7 for this latch at this time.
- i. Once these checks are good, proceed to step 8.

7. AS REQUIRED FOLLOWING CHECKS IN STEP 6: Rig the main gear carriage assembly latches as follows (all rigging adjustments are completed through the main gear tunnel access hole):

- a. Move gear as needed to the main gear tunnel access hole.
- b. Carefully remove the latch spring. While the main gear carriage is installed, the latch spring can be removed after partially removing the AN3 bolt. This is done while the main gear carriage assembly is located just aft of the gear UP lock pin, through the main gear tunnel access hole. Once the spring is removed, verify that both ends push down on the springs and are not flat or bent upwards.
- c. Slide the main gear carriage assembly to lower the latch (UP or DOWN) that needs to be adjusted.
- d. Loosen the latch rigging set screw jamb nut.
- e. Adjust the set screw as needed until the bottom face of the latch is just resting on the carriage block while located over the lowest point of the detent.
- f. Tighten the set screw jamb nut that was loosened.

- g. Repeat steps c through f on the other latch (UP or DOWN) if needed following the checks described in step 6: "Inspect the main gear carriage assembly as follows".
 - h. Reinstall the latch spring and reinstall the AN3 bolt but do NOT over-torque the bolt. Doing so will bind the latches.
 - i. Inspect the latch clearance to the lock pins per step 6: "Inspect the main gear carriage assembly as follows."
8. Rig the main gear position switch magnets on the main gear carriage as follows:
- a. Verify that the magnets on the carriage latch assemblies are adjusted to approximately 1/8" extended out of the latches, as a starting point.
 - b. Rig the gear indication switches per Service Manual Section 2.7.2. The main gear position switch magnets should NOT contact the bulkheads after rigging.
9. AS REQUIRED: Troubleshooting of the main gear indication system (light not illuminating):
- a. Put the gear in position to activate the position switch in question.
 - b. Verify the gear position light bulb is good by changing the bulb from a known good bulb in the gear selector assembly.
 - i. If this check reveals the bulb is bad, replace with a good bulb and verify operation.
 - ii. If the known good bulb does not illuminate, proceed to the next step.
 - c. Place a magnet against the backside of the gear position switch and check for illumination of the gear position light.
 - i. If light illuminates, inspect and adjust indication switches per Service Manual Section 2.7.2, then verify operation.
 - ii. If not, proceed to next step.
 - d. Inspect the wiring for the position system.
 - i. If good, replace the gear position switch and verify operation.
 - ii. If not, repair wiring and repeat troubleshooting.
10. Install the main gear carriage cover.
11. Install the main gear tunnel access cover. As needed, reseal with new caulk strip (or equivalent).
12. Install the top deck access cover just aft of the baggage bay.
13. Reattach the top oleo strut attach bolt with new grease on the bolt and pivot surfaces. Torque this bolt just tight enough not to bind it during operation.
14. Remove jacks from aircraft.

2.7.3 BLEEDING HYDRAULIC SYSTEM AFTER SERVICE

The system automatically bleeds, provided sufficient oil is maintained in the reservoir. To check the fluid level, fill the reservoir with hydraulic oil and cycle the gear. You should notice that the reservoir level drops significantly when the system pressure builds as the accumulator is filling with fluid. You will have to add more fluid at this time. Conversely, when opening a connection in the system a discharge of fluid under pressure will occur as the accumulator empties itself.

Once the accumulator is full the fluid level should be maintained in the upper one third (1/3) of the sight glass. If the reservoir empties (i.e. fluid disappears in sight glass) stop the cycle by pulling the circuit breaker on the control panel. Fill the reservoir again and complete the cycle. Continue this procedure until the fluid level in the reservoir stabilizes (it will vary in level between up and down positions). If the fluid level continues to decline during gear cycles, check for external leaks. Generally, the fluid level in the site glass should be about 3/4 full when the gear is down.

2.7.4 HYDRAULIC ACCUMULATOR SERVICE

The accumulator is pre-charged with nitrogen to a pressure of 225 psi. If recharging becomes necessary (slower than normal probe retraction time of 1 second). Recharge with dry nitrogen gas to a pressure of 225 psi.

2.7.5 NOSE GEAR AXLE AND PIVOT ADJUSTMENT / SHIMMY CORRECTION

Several adjustments can be made to the nose gear to affect its behavior and reduce shimmy tendencies. While shimmy can always be excited by a large nose spring deflection, limiting wheel rotation (gyroscopic effects) and increasing caster friction can limit this tendency and, when shimmy does occur, help center the nose wheel more quickly. A detailed procedure is provided below. Nose spring side-to-side play as described in Section 2.7.1 can also have an effect. These adjustments are in addition to related best practices such as proper tire inflation and wheel balance.

PROCEDURE - SHIMMY CORRECTION MEASURES:

NOTES:

- The following procedures are to be performed with aircraft hoisted or on jacks. Refer to Chapter 1 for instructions.
 - It is recommended that the aircraft not have performed flight operations for 6 or more hours prior to conducting these checks since heat generated during operation can have a noticeable effect, particularly on the setting of the pivot pin retaining nut (step 2).
 - Of the methods described below, step 1 (wheel rotation) has been observed as the most effective means of combating nose wheel shimmy.
 - It may be appropriate to revisit these procedures after a work-in period, especially if shimmy behavior reappears.
 - The instructions below are written for the pivot blocks which utilize a tapered roller bearing. While details may differ, the general concept may be applied to legacy systems.
1. Check and adjust torque on axle nut to limit wheel rotation (see Figure 2.11):
 - a. Confirm that wheel bearings are properly set. May need to slightly over-tighten axle nut to accomplish this, then back off slowly to achieve the behavior described in the following steps.
 - b. By hand and with firm force, spin the nose wheel and observe its rotation.
 - c. Adjust the axle nut to a cotter pin location that results in **approximately 3/4 of a rotation of the wheel**, (more than a half revolution, but less than one).
 - d. Install cotter pin (reference part number MS24665-359).
 2. Check and adjust setting of pivot pin retaining nut atop the pivot block assembly (see Figure 2.12).
 - a. Check that the internal pivot bearing has at a slight pre-load before proceeding. This is accomplished by applying torque to the retaining nut. At a minimum, the washer below this nut should not be able to be spun by hand. The final setting is not far beyond this, but it may be necessary to slightly over-tighten to ensure the bearing is seated. It is recommended that the force values below be found by slowly loosening the nut rather than by tightening. Keep this in consideration while performing the following steps.
 - b. Confirm that the centering mechanism is in its default configuration, meaning no additional force is being produced by the spring by means such as the stacked washers described in step 3.
 - c. Pivot the wheel 90 degrees from detent, hook a push/pull scale to nose fork just above wheel axle, and observe peak force required to pull wheel back towards center. Direction of pull should remain parallel to wheel axle as the assembly pivots.

- d. Target force reading is 10-15 lbs, or as close to it as can be achieved without exceeding 15 lbs. Remove cotter pin (if still installed) and adjust retaining nut as needed. The pivot pin has at least two thru holes allowing the nut to be secured at half-flat intervals.
 - e. Install cotter pin (Reference part number MS24665-359).
3. If shimmy persists after performing steps 1 and 2, through a test flight with multiple landings:
 - a. Repeat steps 1 and 2. If significant adjustments are made, perform another test flight.
 - b. If shimmy continues, add washers or adjust screw (if equipped) at the centering spring. Refer to Figure 2.11A and Figure 2.11B for exploded views of pivot block assemblies. Added washers are to be of the spec NAS1149F08XXP with a maximum recommended stackup of 0.095". As examples, this could be: (1) NAS1149F0832P, (1) NAS1149F0863P, or both combined. Equivalently, loosen jam nut and apply up to two complete turns (maximum recommended) to the adjustment screw, if equipped, from the point it contacts the spring plunger, then tighten jam nut.
 - c. Verify that the pivot block and yoke are not binding and measure the pull force as described in step 2. The measured force would be a new reference baseline and may be different than those above.

NOTE: The force values relate to proper engagement of the bearings within the pivot block and only apply when the centering spring is in its factory configuration, meaning no added washers as described in step 3. Pull force may exceed 15 lbs **only as a result of** performing step 3, which does not affect bearing engagement.

2.8 MAIN AND NOSE GEAR REMOVAL AND DISASSEMBLY

2.8.1 REMOVAL OF MAIN GEAR OLEO

Jack the aircraft by method described in Section 1.2. With main wheels off the ground (both sides), run the gear up so that the main carriage is approximately 2 inches forward of down lock position. This must be accomplished to remove the top oleo bolt. In order to remove the lower bolt, it is necessary to remove the wheel on the head side of the bolt.

2.8.2 REMOVAL OF MAIN GEAR RETRACTION CYLINDER

Relieve pressure in system, place gear selector handle in neutral position (lever between up and down), and remove hydraulic lines. Remove end cap from end of cylinder. Drain fluid. Remove forward end of cylinder from bulkhead flange. Remove both cylinder support rings from the bulkhead.

NOTE: Piston to be in the up position for cylinder removal. Remove cylinder from piston and up through top float inspection cover.

To remove the piston, remove top inspection cover on top forward end of gear tunnel, accessible from the top float inspection cover forward of the step. Pull back piston to expose top of carriage in center of access cover. Remove 0.25 diameter retention bolt. Remove piston by pulling aft. See Figure 2.7 for part breakdown.

2.8.3 REMOVAL OF MAIN GEAR DRAG LINK

Remove drag link from trunnions on step bulkhead. Axle is heat shrunk to drag link and is not removable.

2.8.4 REMOVAL OF NOSE GEAR TROLLEY FROM NOSE BOX

Gear must be in down position. Unbolt the spring from the trolley. Relieve the pressure in system, place gear selector handle in neutral position (lever between up and down), and remove rear hydraulic line. Remove (4) bolts on forward end of cylinder. Drain fluid. Pull aft to expose internal piston rod. Loosen jamb nut on forward side of cylinder ram at rod end. Turn piston from aft side of nose box out of rod end. Push on trolley assembly to unlock and remove the bottom thru-bolts. Slide out of nose box.

NOTE: On installation, adjust piston so it bottoms out on aft flange at the same time as the bearings when nose gear is in locked position. Also note orientation of trolley blocks. The side with the most edge distance from hole is to go toward each other on inside of trolley. (See Figure 2.10 for details).

2.8.5 REMOVAL OF NOSE GEAR BOX

Remove bolts securing forward box from nose bulkhead. Remove bolts securing aft box from bulkhead (2). Slide box out from front of float.

NOTE: Sealant will have to be cut for removal and replaced when installing.

2.8.6 REMOVAL OF LOWER NOSE GEAR FROM PIVOT BLOCK

On top of pivot block, remove cotter pin from retaining nut. Remove nut. On aft side of pivot block, remove the (2) cap bolts on .25 thick cover. Remove spring. This will loosen retaining ball and lower fork will slide out. Refer to Figure 2.11 for assembly.

NOTE: Torque on retaining nut provides setting of the internal roller bearing and is not to be over-tightened. See Section 2.7.5 for more details.

2.8.7 TO REMOVE THE NOSE GEAR

Remove the nose gear from the nose box by unbolting the spring (4 bolts).

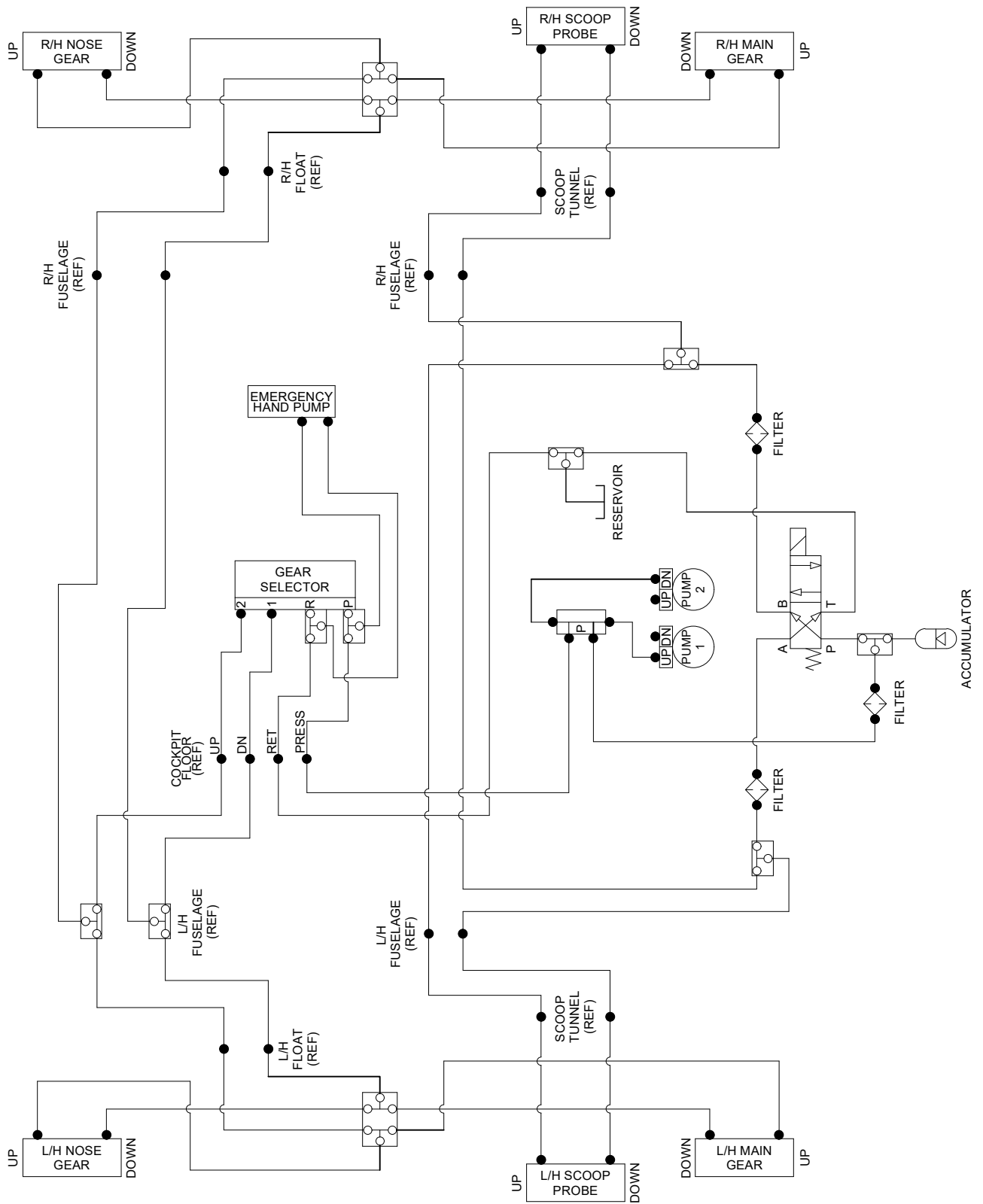
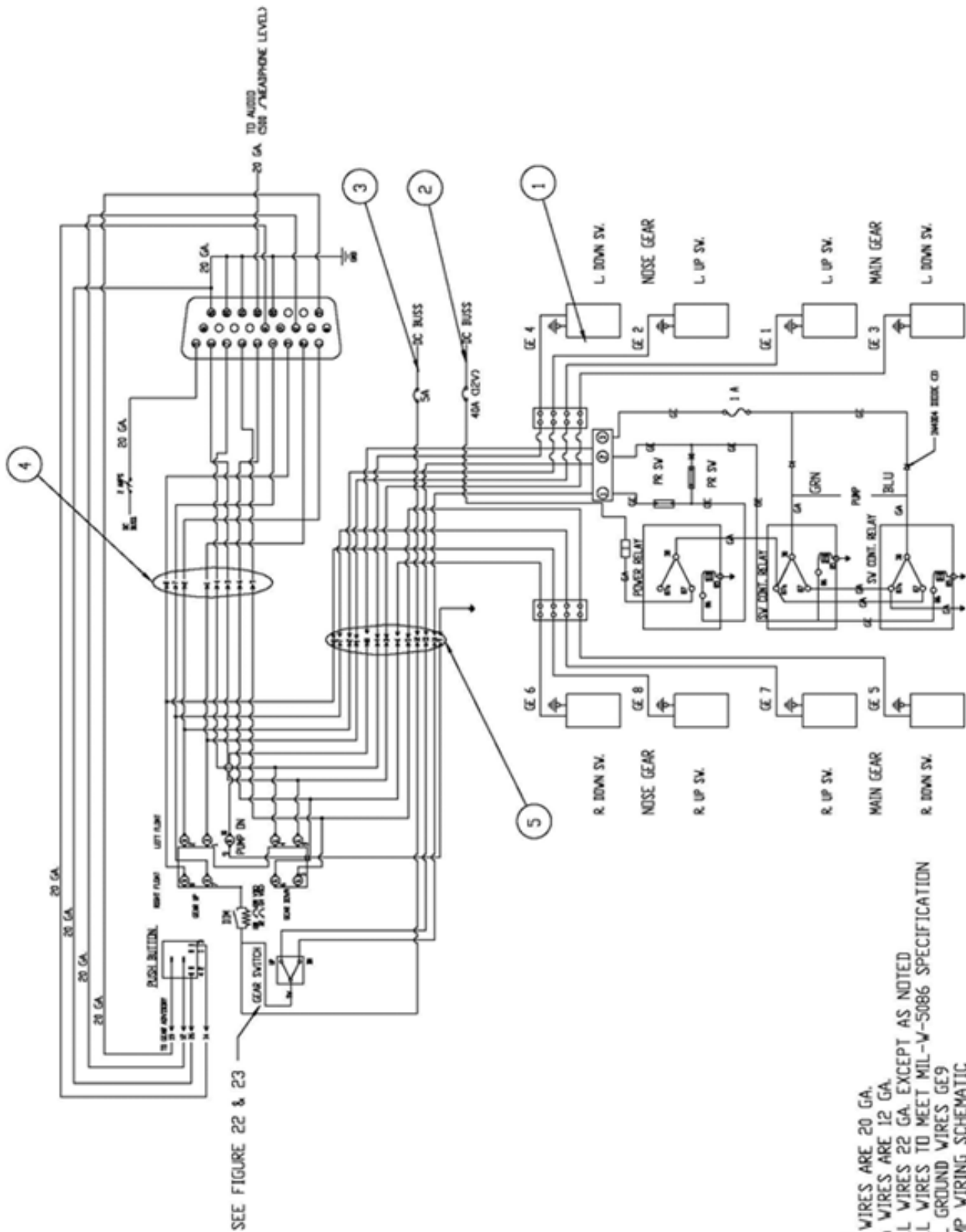

FIGURE 2.2 SCHEMATIC - HYDRAULIC SYSTEM



SEE FIGURE 22 & 23

- NOTES:
1. GE WIRES ARE 20 GA.
 - GA WIRES ARE 12 GA.
 - ALL WIRES 22 GA. EXCEPT AS NOTED
 - ALL WIRES TO MEET MIL-W-5086 SPECIFICATION
 2. ALL GROUND WIRES GE9
 3. PUMP WIRING SCHEMATIC (RELAYS SHOWN IN RELAXED CONDITION)

FIGURE 2.3 SCHEMATIC - ELECTRICAL SYSTEM

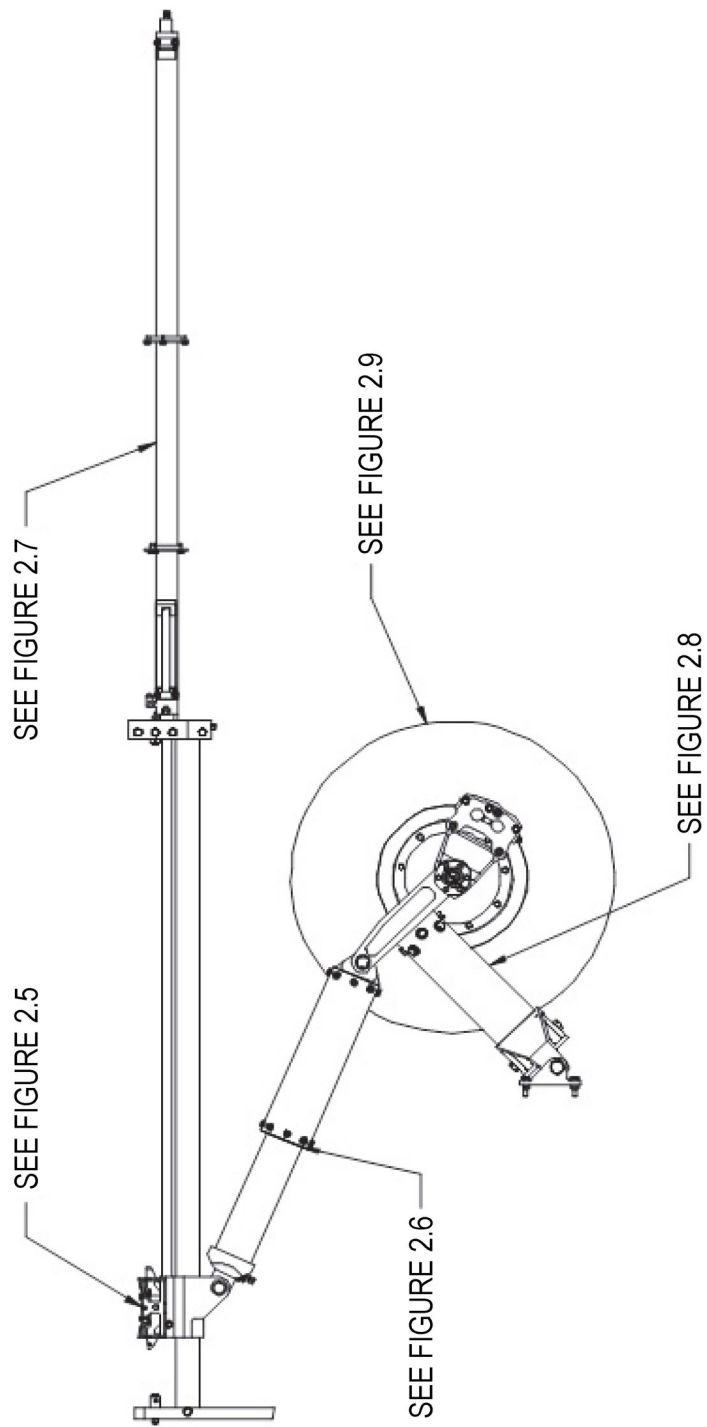

FIGURE 2.4 LAYOUT – MAIN GEAR

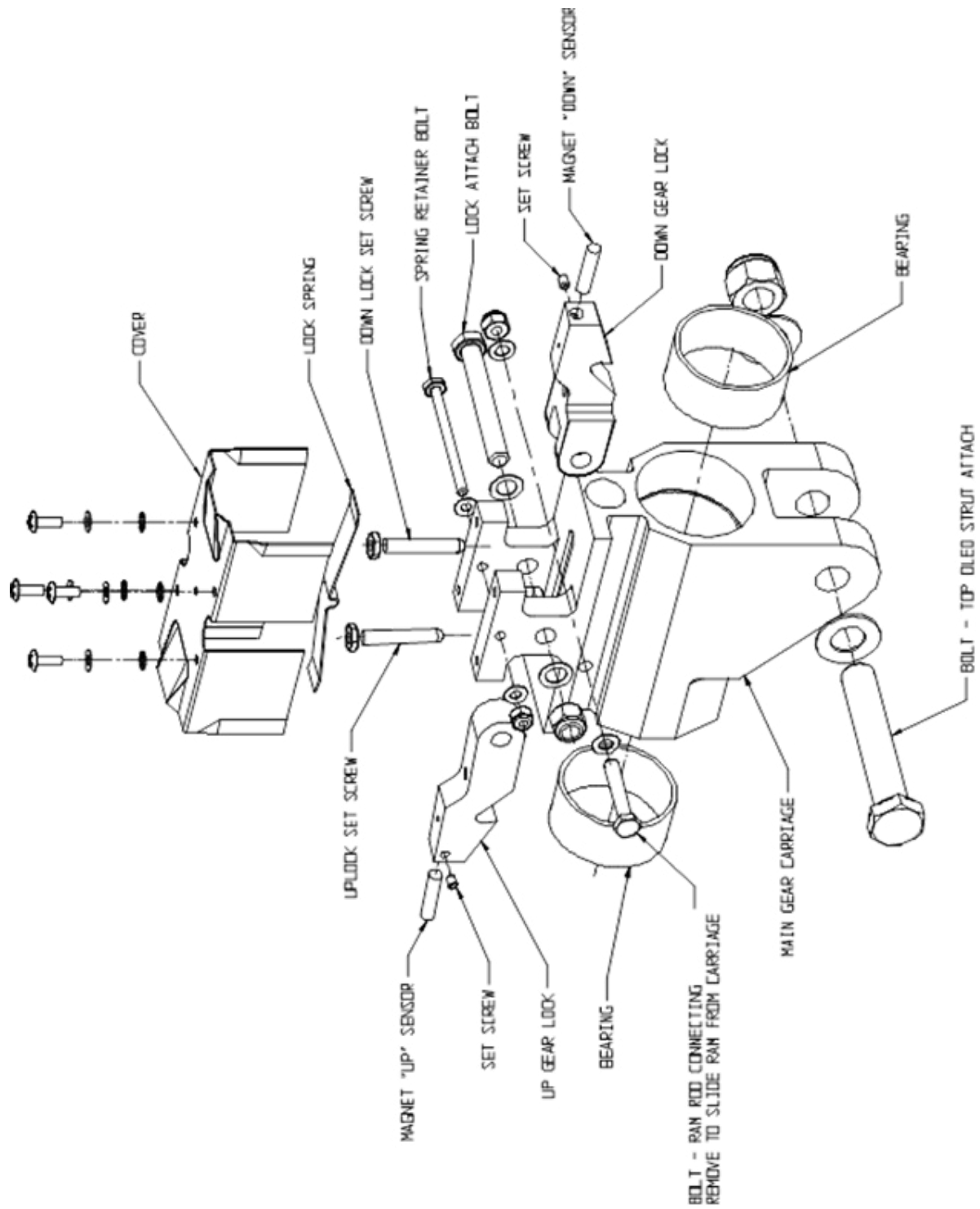

FIGURE 2.5 CARRIAGE ASSEMBLY – MAIN GEAR

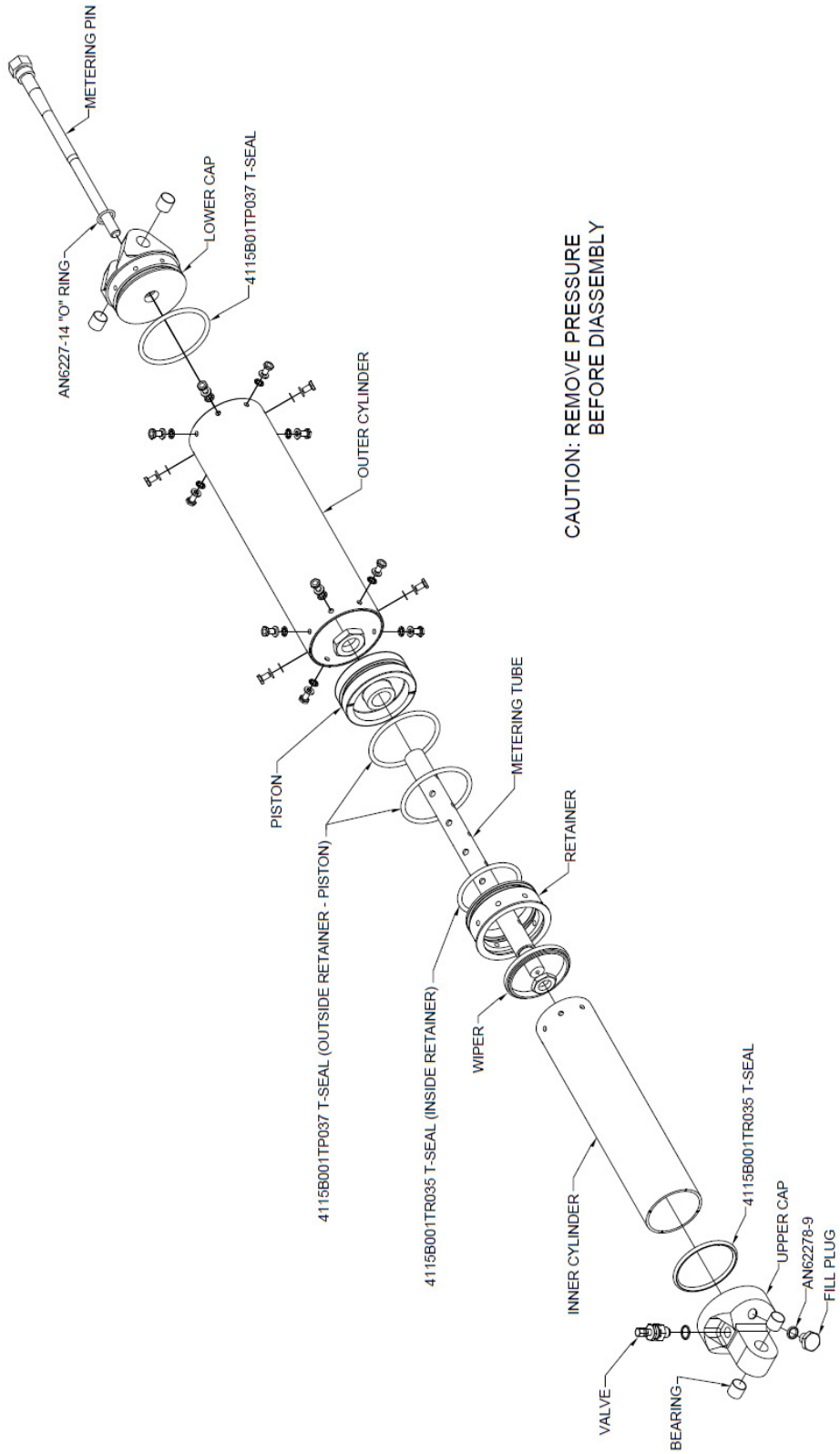

FIGURE 2.6 ASSEMBLY – MAIN GEAR SHOCK STRUT

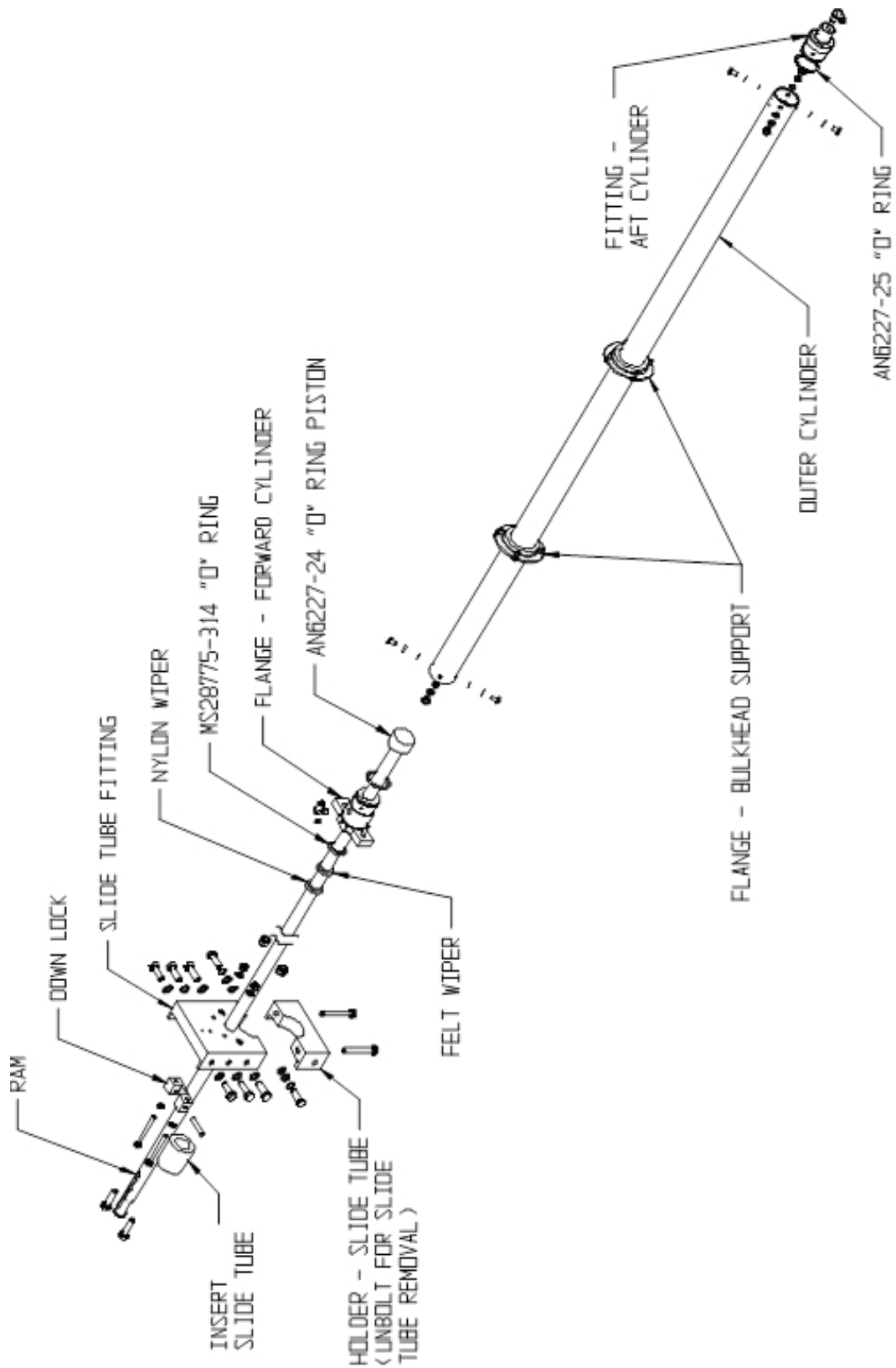

FIGURE 2.7 ASSEMBLY – MAIN GEAR ASSEMBLY

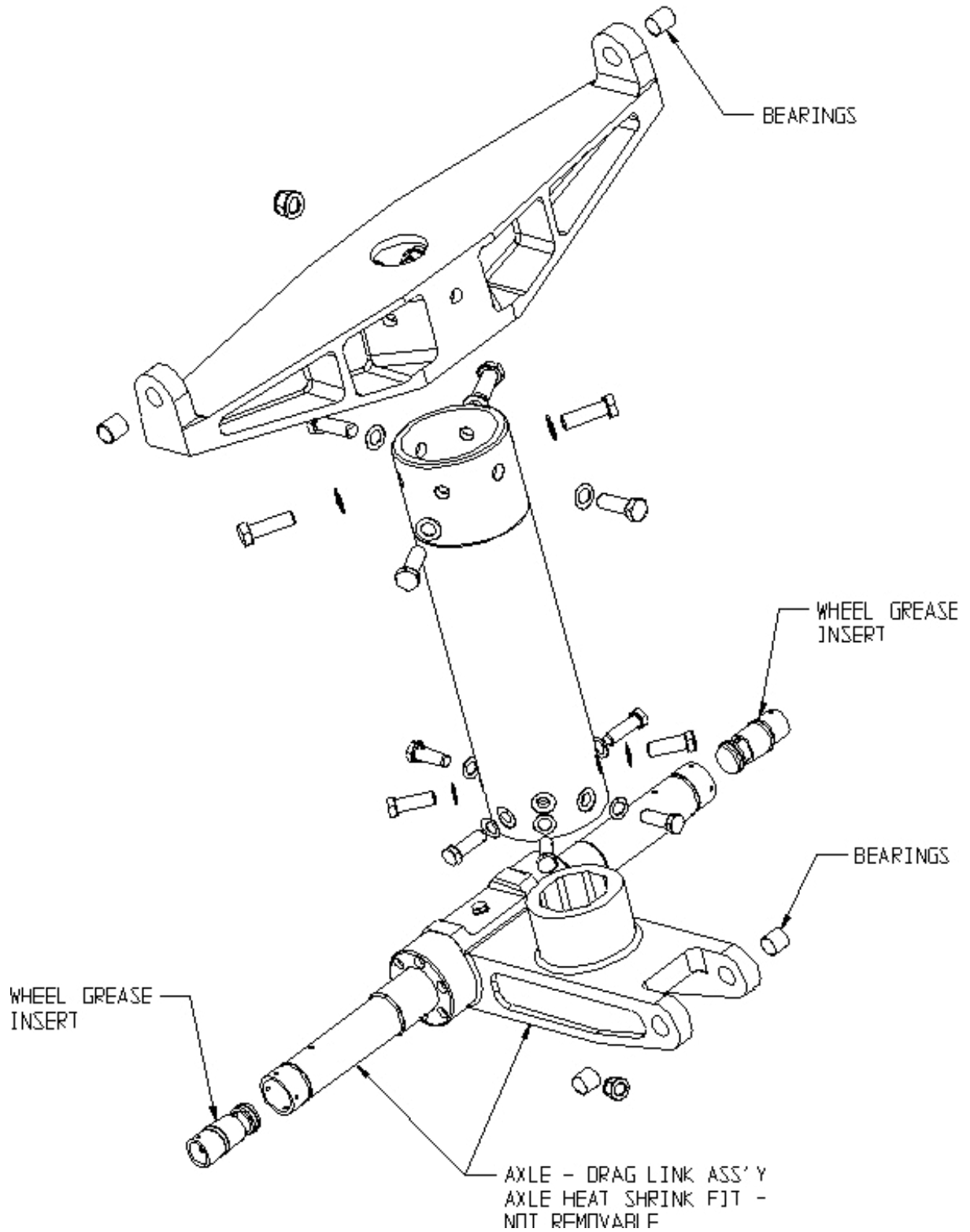

FIGURE 2.8 ASSEMBLY – MAIN GEAR DRAG LINK

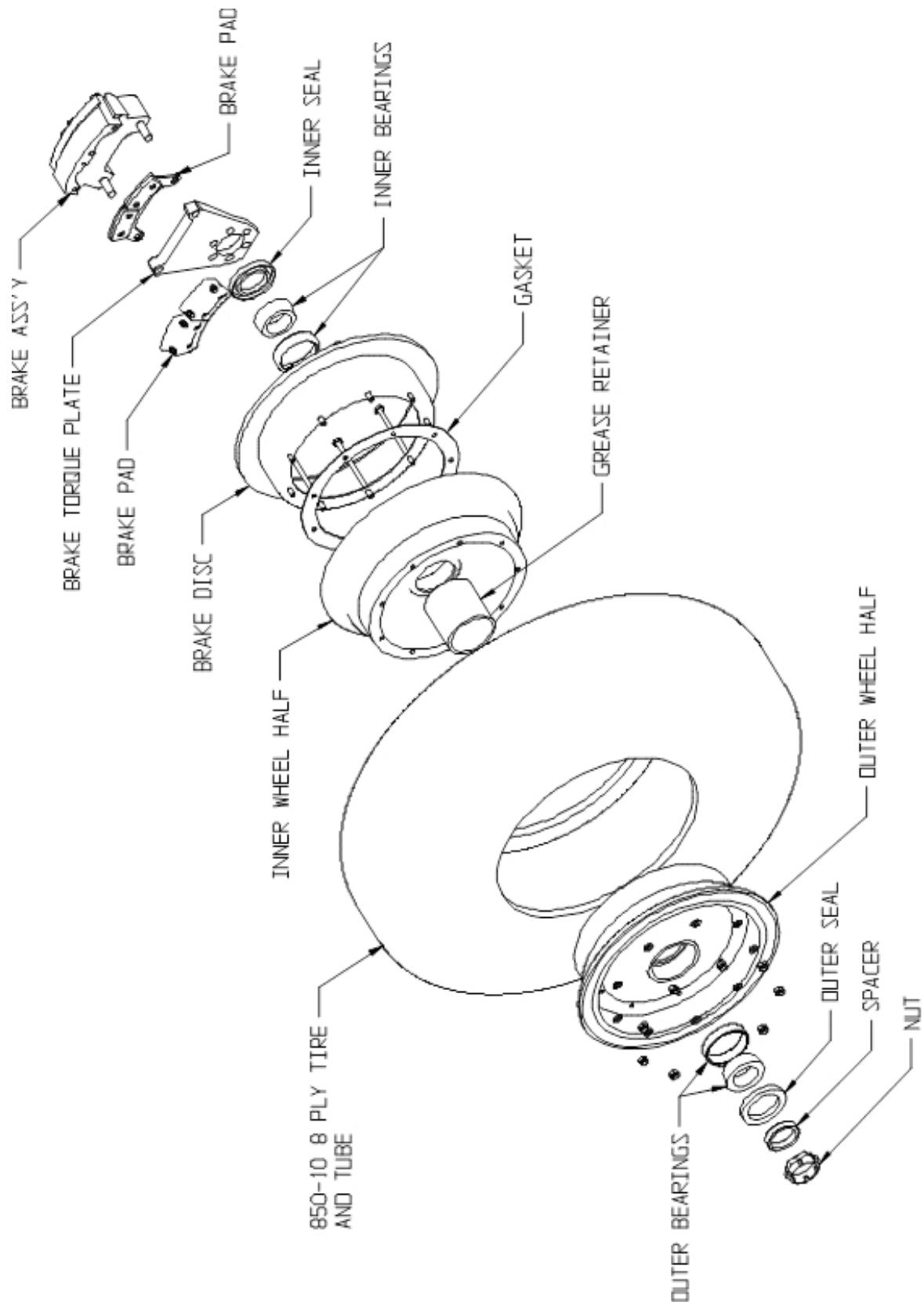

FIGURE 2.9 ASSEMBLY – MAIN GEAR WHEEL AND BRAKE

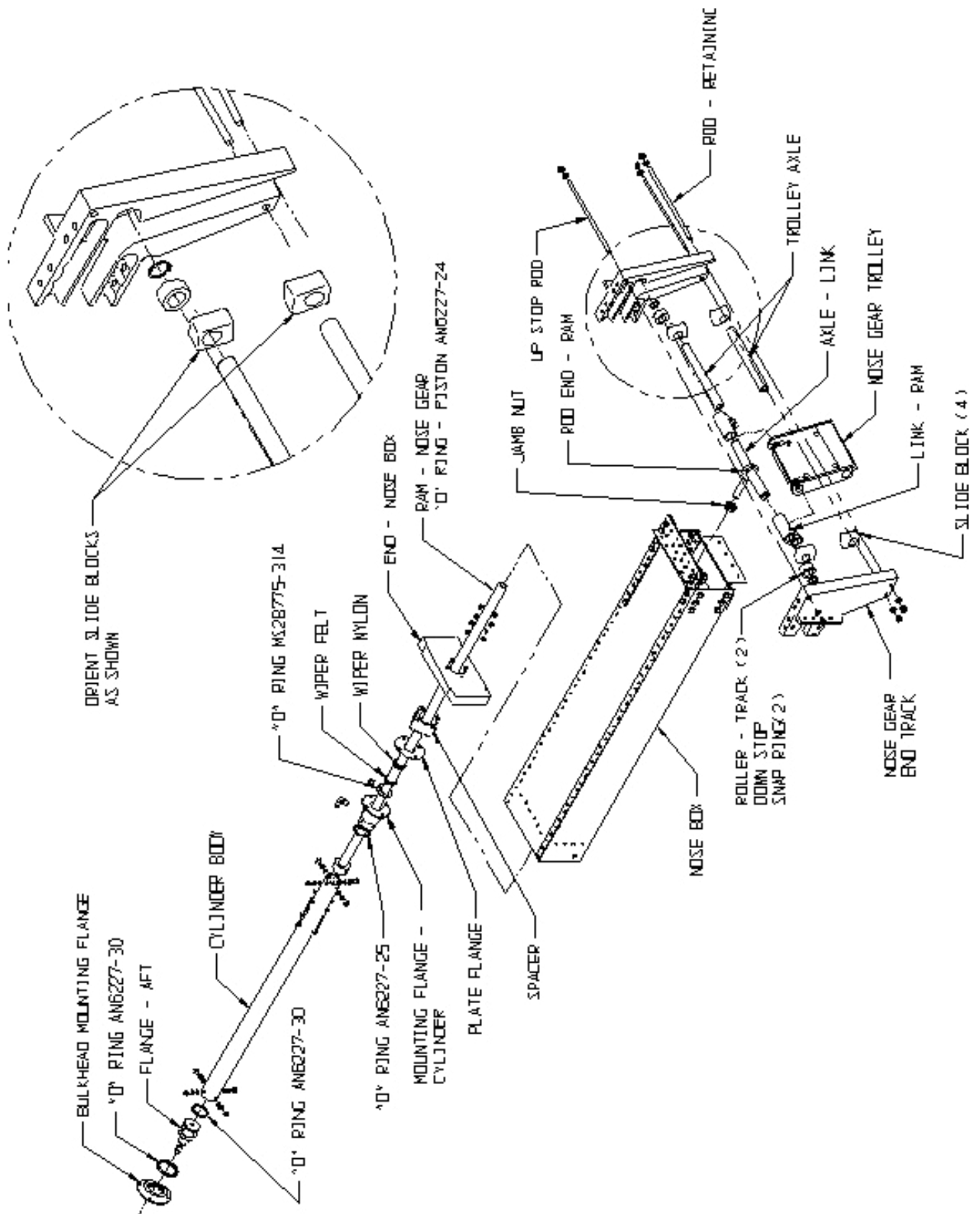

FIGURE 2.10 ASSEMBLY – NOSE GEAR BOX AND RETRACTION

FLOAT SERIAL NUMBERS 10315A AND LATER

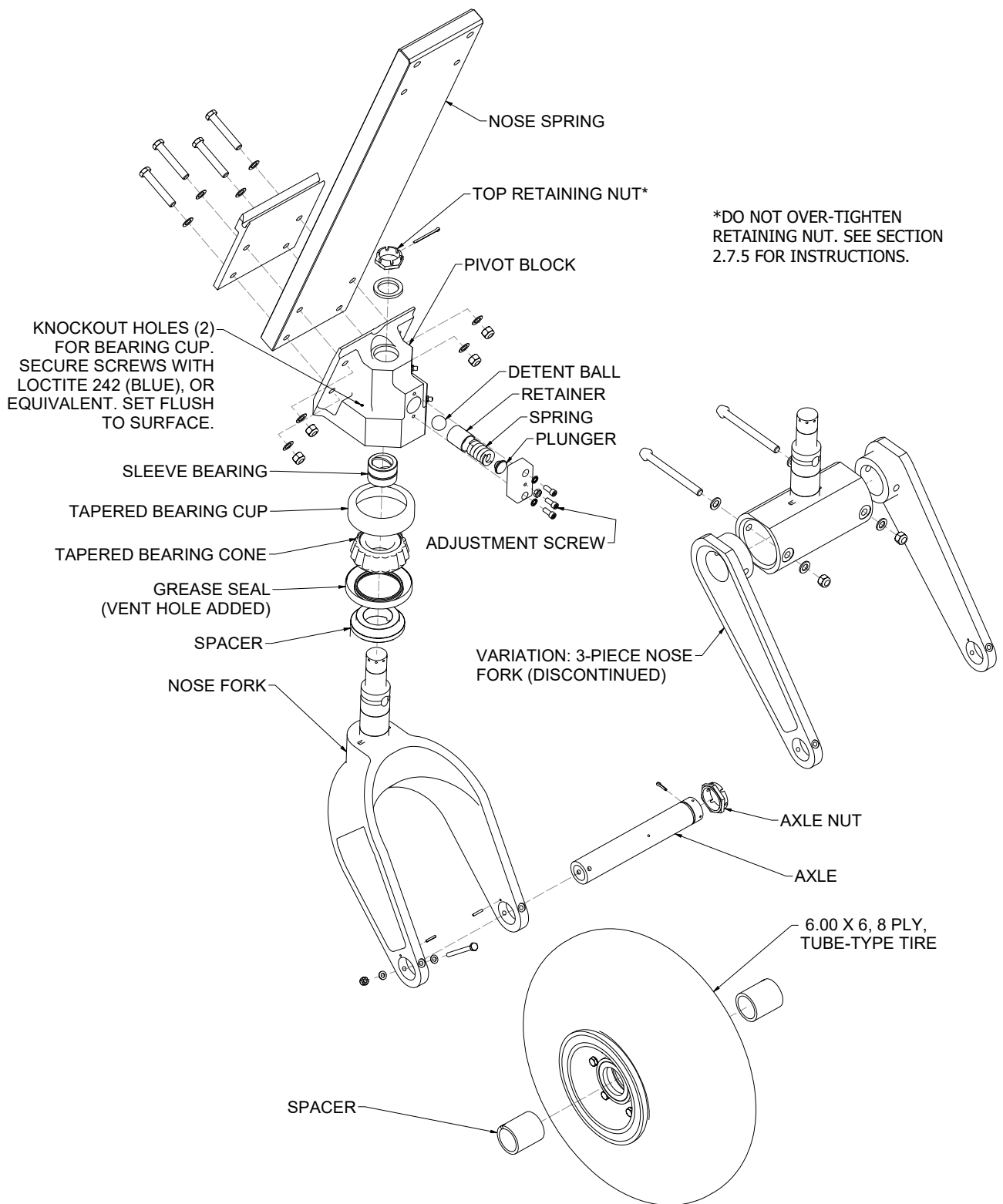

FIGURE 2.11A ASSEMBLY – NOSE GEAR LOWER END (NEW VERSION)

FLOAT SERIAL NUMBERS 10314A AND PRIOR

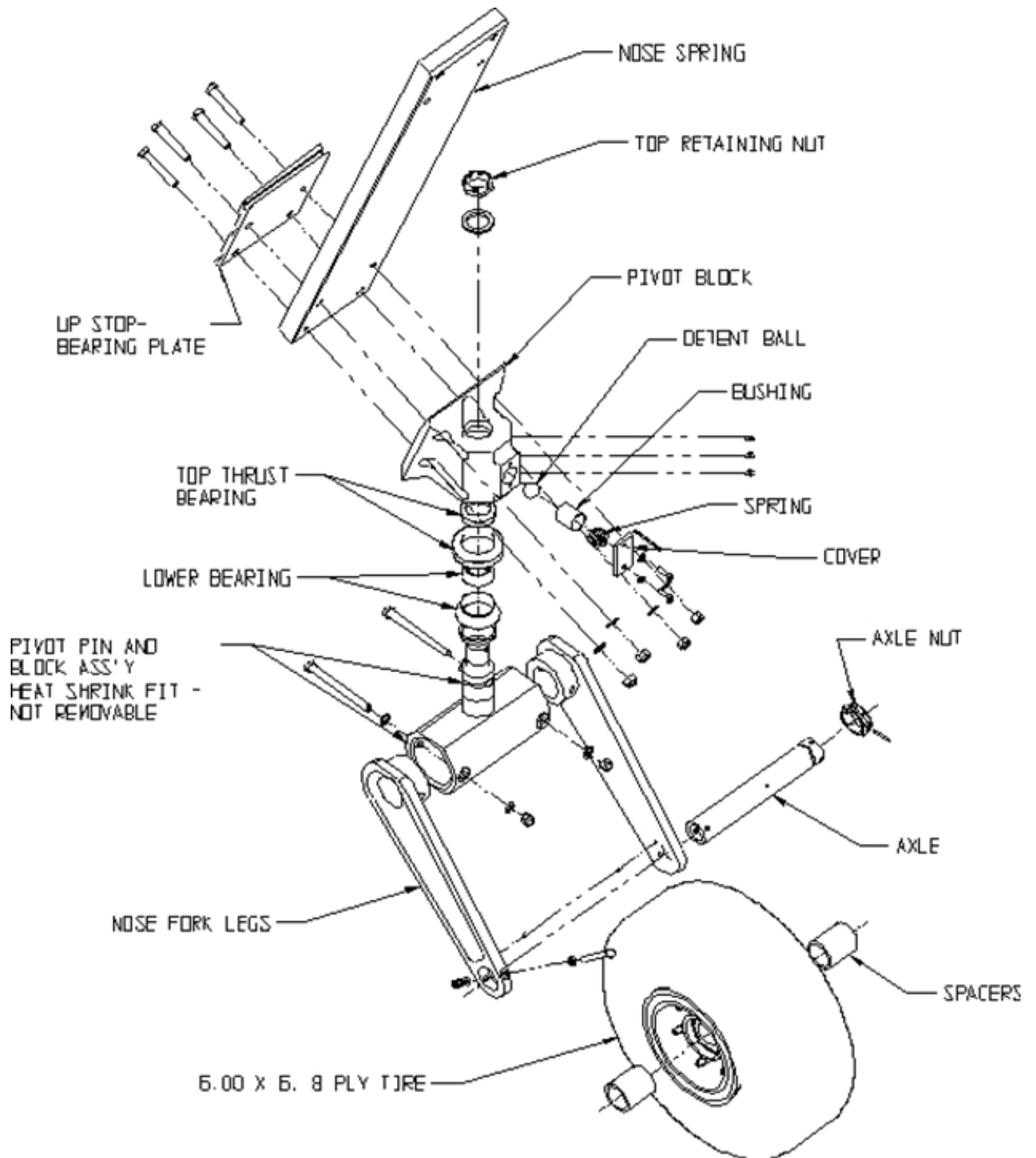

FIGURE 2.11B ASSEMBLY – NOSE GEAR LOWER END (OLD VERSION)

NOSE GEAR PIVOT RESISTANCE TEST

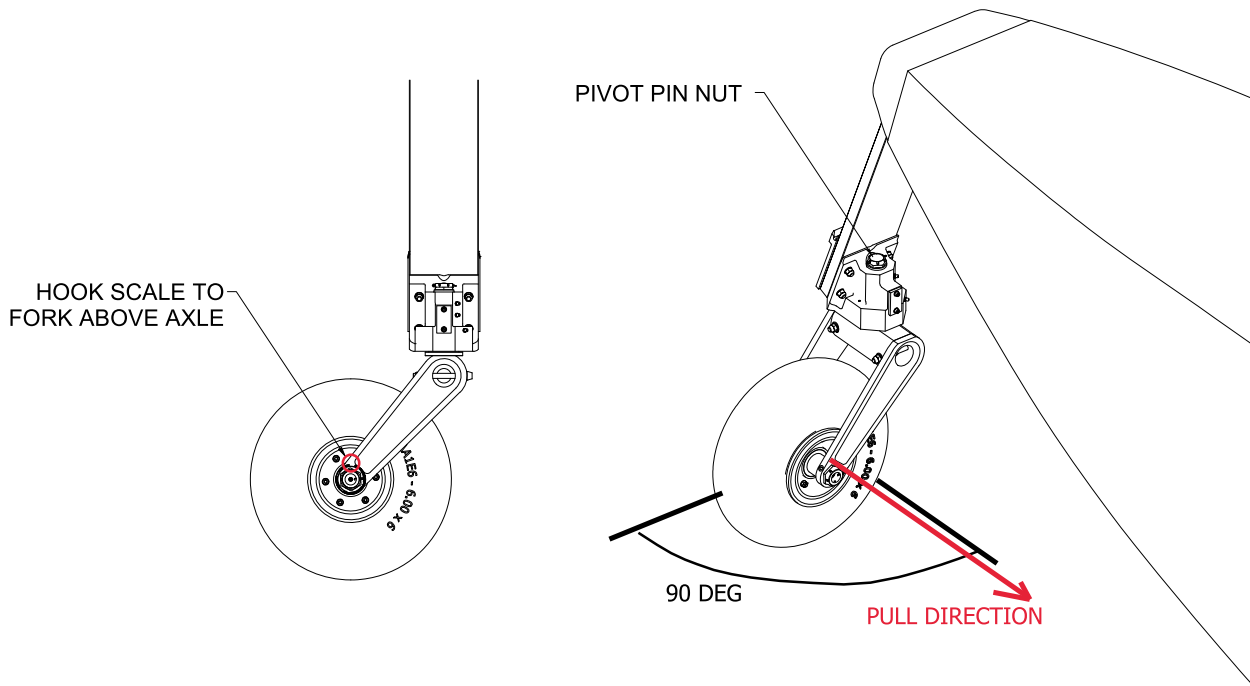

FIGURE 2.12 NOSE GEAR PIVOT RESISTANCE TEST

NOSE GEAR SPRING SIDE-TO-SIDE PLAY CHECK



FIGURE 2.13 NOSE GEAR SPRING SIDE-TO-SIDE PLAY CHECK

THIS PAGE INTENTIONALLY LEFT BLANK

CHAPTER 3 HYDRAULIC PUMP SYSTEM, DISASSEMBLY AND SERVICE

CONTENTS

3.1 GENERAL, OILDYNE PUMPS	48
3.2 GENERAL, BUCHER PUMPS FUSELAGE STA. 159.50.....	48
3.3 GENERAL, BUCHER PUMPS FUSELAGE STA. 67.88.....	49
3.4 OPERATION TROUBLESHOOTING	49

CHAPTER 3 - HYDRAULIC PUMP SYSTEM, DISASSEMBLY AND SERVICE

3.1 GENERAL, OILDYNE PUMPS

The Oildyne hydraulic pump located at fuselage station 159.50 is factory preset to the following pressures:

Pressure switch is a normally closed circuit that opens on increasing pressure of ~1,200 psi and closes on decreasing pressure before 525 psi.

The pump also has an internal relief valve that opens at ~1,450 psi and a thermal relief valve that opens at ~2,000 psi. These pressures are set with factory test equipment and are recommended to be sent back for overhaul or repair.

The hydraulic pump may be disassembled for cleaning.

1. Relieve the pressure in the hydraulic system by pulling the PUMP 1 and PUMP 2 circuit breakers.
2. Place the gear selector handle in the neutral position (between up and down).
3. On the forward lower side of the reservoir, remove drain plug to drain most of the hydraulic oil.

Note: Due to the confines of the hydraulic powerpack installation, the powerpack will need to be lifted up and supported with a ratchet strap or something similar while loosening up the clamps that attach the powerpack to the aircraft tubing. This will lift the assembly up far enough to remove the reservoir.

4. Remove the (4) screws from the upper side of the reservoir.
5. Dump out remaining oil, and clean reservoir.
6. Unscrew the standpipe from each hydraulic pump that has a screen attached at the bottom.
7. Clean filter screen and reinstall onto pump.
8. If filter screens are removed from standpipe, a new filter screen should be used.
9. Reinstall reservoir and install seals to top of reservoir before installing on pumps.
10. Install drain plug and fill with clean MIL-H-5606 hydraulic oil through the breather pipe.
11. The hydraulic oil level should be at the operating fill level line with the gear in the down position.
12. Remove and clean the three in-line filters located above and adjacent to the accumulator, aft of the hydraulic pumps.
13. If the hydraulic oil is not a clean, red color, it should be replaced with new MIL-H-5606 hydraulic oil.

3.2 GENERAL, BUCHER PUMPS FUSELAGE STA. 159.50

The Bucher hydraulic pump located at fuselage station 159.50 is factory preset to the following pressures:

Pressure switch is a normally closed circuit that opens on increasing pressure of ~1,200 psi and closes on decreasing pressure before 525 psi.

The pump also has an internal relief valve that opens at ~1450 psi and a thermal relief valve that opens at ~2,000 psi. These pressures are set with factory test equipment and are recommended to be sent back for overhaul or repair.

The hydraulic pump may be disassembled for cleaning.

1. Relieve the pressure in the hydraulic system by pulling the PUMP 1 and PUMP 2 circuit breakers.
2. Place the gear selector handle in the neutral position (between up and down).
3. On the lower side of the reservoir, remove the drain plug to drain most of the hydraulic oil.

Note: Due to the confines of the hydraulic powerpack installation, the powerpack will need to be lifted up and supported with a ratchet strap or something similar while loosening up the clamps that attach it to the aircraft tubing. This will lift the assembly up far enough to remove the reservoir.

4. Remove the (8) screws from the upper side of the reservoir.
5. Dump out remaining hydraulic oil, and clean reservoir.
6. Unscrew the standpipe from each hydraulic pump that has a screen attached at the bottom.
7. Clean filter screen and reinstall onto pump.
8. Reinstall reservoir and verify seals are in place between the reservoir and bottom of hydraulic pump manifold.
9. Install drain plug and fill with clean MIL-H-5606 hydraulic oil through the fill port on the reservoir.
10. The hydraulic oil level should be at the operating fill level line with the gear in the down position.
11. Remove and clean the three in-line filters located above and adjacent to the accumulator, aft of the hydraulic pumps.
12. If the hydraulic oil is not a clean, red color, it should be replaced with new MIL-H-5606 hydraulic oil.

3.3 GENERAL, BUCHER PUMPS FUSELAGE STA. 67.88

The Bucher hydraulic pump located at fuselage station 67.88 is factory preset to the following pressures:

Pressure switch is a normally closed circuit that opens on increasing pressure of ~1,200 psi and closes on decreasing pressure before 525 psi.

The pump also has an internal relief valve that opens at ~1,450 psi and a thermal relief valve that opens at ~2,000 psi. These pressures are set with factory test equipment and are recommended to be sent back for overhaul or repair.

The hydraulic pump may be disassembled for cleaning.

1. Relieve the pressure in the hydraulic system by pulling the PUMP 1 and PUMP 2 circuit breakers.
2. Place the gear selector handle in the neutral position (between up and down).
3. On the lower side of the reservoir, remove the drain plug to drain most of the hydraulic oil.
4. Remove the (8) screws from the upper side of the reservoir.
5. Dump out remaining hydraulic oil, and clean reservoir.
6. Unscrew the standpipe from each hydraulic pump that has a screen attached at the bottom.
7. Clean filter screen and reinstall onto pump.
8. Reinstall reservoir and verify seals are in place between the reservoir and bottom of hydraulic pump manifold.
9. Install drain plug and fill with clean MIL-H-5606 hydraulic oil through the fill port on the reservoir.
10. The hydraulic oil level should be at the operating fill level line with the gear in the down position.
11. Remove and clean the three in-line filters located below and adjacent to the accumulator, right of the hydraulic pumps.
12. If the hydraulic oil is not a clean, red color, it should be replaced with new MIL-H-5606 hydraulic oil.

3.4 OPERATION TROUBLESHOOTING

1. PROBLEM – Powerpack does not run after gear selection.

PROBABLE CAUSE:

- a. Circuit breaker has tripped.
- b. Pressure switch not closing before 525 psi.
- c. Electrical solenoid contacts are not closing.
- d. Faulty pump motor.

- e. Motor not properly grounded.

VERIFICATION AND REMEDY:

- a. Reset circuit breaker.
- b. Install a 20 gauge jumper wire between ground and the ground post for the coil on the electrical solenoid. If the motor runs, replace the pressure switch.
- c. Install a 12 gauge jumper wire between supplied 24VDC on the electrical solenoid terminal to the positive terminal on the motor. If the motor operates, replace the electrical solenoid.
- d. If the above steps do not produce results and it is verified that voltage was actually applied to the motor, it can be assumed the motor is bad or not properly grounded.
- e. Check motor ground.

2. PROBLEM – Powerpack does not shut off after gear reaches position.

PROBABLE CAUSE:

- a. Pressure switch not opening at ~1,200 psi.
- b. Faulty or dirty pressure relief valve allowing insufficient pressure buildup.

VERIFICATION AND REMEDY:

- a. Remove pressure switch wires from ground point and electrical solenoid. With a multimeter, check continuity of pressure switch. If there is continuity, replace the pressure switch.
- b. Clean and check proper relief valve.

3. PROBLEM – Powerpack shuts off before gear reaches position.

PROBABLE CAUSE:

- a. Binding or jammed gear actuator, which causes pressure to build up (and stay up), and pressure switch shuts off powerpack.
- b. Faulty or dirty pressure relief valve allowing insufficient pressure to build up.

REMEDY:

- a. Locate and repair damaged gear actuator.
- b. Clean and check proper relief valve.

4. PROBLEM – Powerpack cycles on and off after gear is in position.

PROBABLE CAUSE:

- a. External hydraulic leak.
- b. Internal hydraulic leak.

VERIFICATION AND REMEDY:

- a. Verify hydraulic oil level in reservoir. Visually inspect hydraulic lines, gear actuators, manifolds, and fittings. Replace as necessary.

- b. If no external leaks are found, disconnect and cap off one gear actuator and hydraulic lines, one at a time. Operate hydraulic powerpack to see if the problem is resolved. Keep checking gear actuators until the leaking actuator is found. If the isolating system still indicates internal leaks and the hydraulic pumps are Oildyne pumps, the pump check valve (located in the pressure port of pump) is bad and needs replacement or reseating.

5. PROBLEM – Powerpack cycles on and off during gear cycle.

PROBABLE CAUSE:

- a. Binding in main landing gear or nose box assembly.
- b. Pressure switch is turning the hydraulic pumps off before reaching ~1,200 psi.

REMEDY:

- a. Investigate for free operation of the landing gear. Check gear that retracts last.
- b. Replace pressure switch.

6. PROBLEM – Slow gear operation cycle.

PROBABLE CAUSE:

- a. Plugged oil screen.
- b. Bad motor or poor electrical connection to motor.
- c. Worn pump gears.
- d. Low aircraft voltage.

REMEDY:

- a. Clean intake screens located inside the hydraulic pump reservoir.
- b. Connect motor direct to 24 volt source and note its operation; if operation is good, wire connection is bad; if operation is poor, motor needs overhauled or replaced.
- c. Replace pump(s).
- d. Check aircraft voltage.

7. PROBLEM – Circuit breaker trips during gear operation.

PROBABLE CAUSE:

- a. Wire connections are loose or corroded.
- b. Faulty motor.
- c. Faulty circuit breaker.

REMEDY:

- a. Clean and protect terminals with dielectric grease.
- b. Overhaul or replace motor.
- c. Replace circuit breaker.

THIS PAGE INTENTIONALLY LEFT BLANK

CHAPTER 4 SCOOP SYSTEM OPERATION, REMOVAL AND SERVICE

CONTENTS

4.1 DESCRIPTION AND OPERATION.....	54
4.2 ADJUSTMENT AND TEST	54
4.3 REMOVAL OF SCOOP AND FILL SYSTEM.....	54
4.4 SERVICE – SCOOP SYSTEM.....	55
4.5 SERVICE OF HYDRAULIC DIRECTIONAL VALVE – SCOOP RETRACTION	55
4.6 SERVICE OF IN-LINE FILTERS – SCOOP RETRACTION	55
4.7 ASYMMETRIC SCOOP REPORTING	55

CHAPTER 4 - SCOOP SYSTEM OPERATION, REMOVAL AND SERVICE

4.1 DESCRIPTION AND OPERATION

Full operating information of scooping system is described in Introduction Section 1.4. The scoops (one in each float) are hydraulically operated. Hydraulic Schematic Figure 2.2 shows how the scooping system is integrated with the landing gear hydraulic system. The only moving part in the scooping system is the lower probe assembly which is actuated hydraulically by the probe jack cylinder. See Figure 4.1 for view of the entire scooping system.

4.2 ADJUSTMENT AND TEST

The lower probe assembly is set at the factory for full open and close positions. Any adjustment necessary to the probe is accomplished by adjusting the probe jack cylinder. Figure 4.2A shows a cross section of the cylinder. Figures 4.2B and 4.2C illustrate the setting of the up and down positions, respectively. Set the up position first. Begin by extending the cylinder shaft with hydraulic pressure to ensure full extension. While extended, the clevis should bolt to the probe when the bottom of the probe is clear of the float keel by approximately 1/8". Turn the clevis as necessary to meet this condition. Once the up position is set, the down position is set by adjusting the stop collar. The stop collar should meet the cylinder body when the top/inner surface of the probe is flush with the float keel. The hydraulic lines may be disconnected to facilitate adjusting and checking the down position by hand. Apply Loctite 290 (green) threadlocker or equivalent to both jam nuts and torque to 90-100 in-lbs. Jam nuts may alternatively be NAS509 or NAS1423 drilled jam nuts to be secured with safety wire. After adjustment reconnect hydraulic lines as needed and cycle probe for proper operation. Check if probe up and down position lights are operating properly.

4.3 REMOVAL OF SCOOP AND FILL SYSTEM

Lower Scoop Assembly and Scoop Cylinder

Remove attaching bolt for scoop assembly accessible from outside of the float. Drop down and disconnect the rod end from the probe jack cylinder. For removal of the cylinder, remove attaching bolt accessible from outside of the float. From inside of the float, remove forward top tunnel access cover. Remove hydraulic lines and remove cylinder.

Scoop Tube Assembly – Internal

Remove access covers on left and right side skins just forward of step. From these holes, unsafety clamp connecting the 2 scoop tubes. Remove forward leading edge fairings from the main gear pylon. Unclamp and remove the connecting hose to upper filler pipe. Remove the bolts attaching upper attach flange to the float top deck. Slide out scoop tube from the top. When reinstalling, check condition or replace gasket in connecting clamp.

Upper Probe Scoop Assembly

With the lower scoop and internal scoop tube removed, unbolt scoop from float tunnel. Break sealant and remove from the top. Reseal cover on reinstallation.

Filler Tube – Main Gear Pylon

Remove fairings, unbolt attaching clamps, and disconnect connecting hose. Remove hose. Before reinstalling, check condition or replace clamp chafing strips.

Fill Tube at Aircraft Tank

From inside and outside of tank, remove attaching bolts. Break sealant on inside and outside flanges. Remove from inside tank. On reinstallation, seal completely and reattach.

4.4 SERVICE – SCOOP SYSTEM

Figure 4.2A shows a cross section of the hydraulic probe cylinder. Replace “O” rings if cylinder shows signs of leaking. Check for security of the jam nuts against the clevis and stop collar. If needed, apply Loctite 290 (green) threadlocker or equivalent and torque jam nuts to 90-100 in-lbs. Jam nuts may alternatively be NAS509 or NAS423 drilled jam nuts to be secured with safety wire. A gasket is between upper probe and internal tube at connecting clamp. Replace if necessary. Check condition of connecting hose and clamps above float deck (2) each side. Inside of aircraft tank on each inlet tube there is a rubber flapper valve or a platypus type valve. Check if valve is closing tight and condition of valve. Replace if necessary.

4.5 SERVICE OF HYDRAULIC DIRECTIONAL VALVE – SCOOP RETRACTION

If scoop probes stick, it may be necessary to clean the directional valve. For powerpack installations at fuselage station 159.50, the directional valve is located aft of the hydraulic pumps and above the accumulator. For powerpack installation at fuselage station 67.88, the directional valve is located to the right of the hydraulic pumps and below the accumulator. Pull both the PUMP 1 and PUMP 2 circuit breakers and relieve the pressure in the hydraulic system by placing the gear selector in the neutral position (between up and down). Remove the large (.94”) hex nut located on the side of the directional valve. Remove spring and gently remove spool valve. Remove the electrical box cover (the one with the amber light) by loosening the two center, round knobs. Pull off electrical box. Remove solenoid block from the manifold by removing the four allen hex head bolts. Clean the solenoid block and manifold by carefully blowing air through the ports. Reinstall the block onto the manifold with the four allen hex-head bolts and their accompanying O-rings. Reinstall the electrical box and cover. Clean the spool valve and gently reinstall it. Reinstall the spring and nut.

Note: This above procedure should be in conjunction with cleaning of the entire hydraulic system, in-line filter elements, and removing the hydraulic pump reservoir and cleaning the filters in Section 3.

4.6 SERVICE OF IN-LINE FILTERS – SCOOP RETRACTION

On the pressure port of the directional valve is an in-line filter element. To service and clean this filter element, unscrew the hex end from the flat end. Remove the filter element and note the placement of the internal spring. Clean the filter element by washing in clean solvent and blowing compressed air through the inside of the filter. Check the condition of the O-ring before reassembling. Lines from directional valve ports “A” and “B” are two in-line filter elements. To service and clean these filter elements, unscrew one end from the outer case. Remove the filter retainer and filter element. Clean the filter element by washing in clean solvent and blowing compressed air through the filter. Check the condition of the O-ring before reassembling.

4.7 ASYMMETRIC SCOOP REPORTING

In order to gather fleet operational data, Wipaire needs the following information to be reported when a suspected asymmetrical scoop event leads maintenance to ground the aircraft to investigate the possible event:

- Date and local time
- Aircraft identifier
- Location and scooping direction
- Weather, including wind and water surface conditions

SERVICE MANUAL & ICA
10000 AMPHIBIAN FLOATS ON AIR TRACTOR AT-802A

- Summary of activity preceding the event (i.e. number of scoops that day, time since previous maintenance)
- Symptoms that lead to suspecting an asymmetric scoop event occurred
- Results of the investigation

Provide the preceding information to Wipaire Customer Support as soon as practical after the maintenance action is completed.

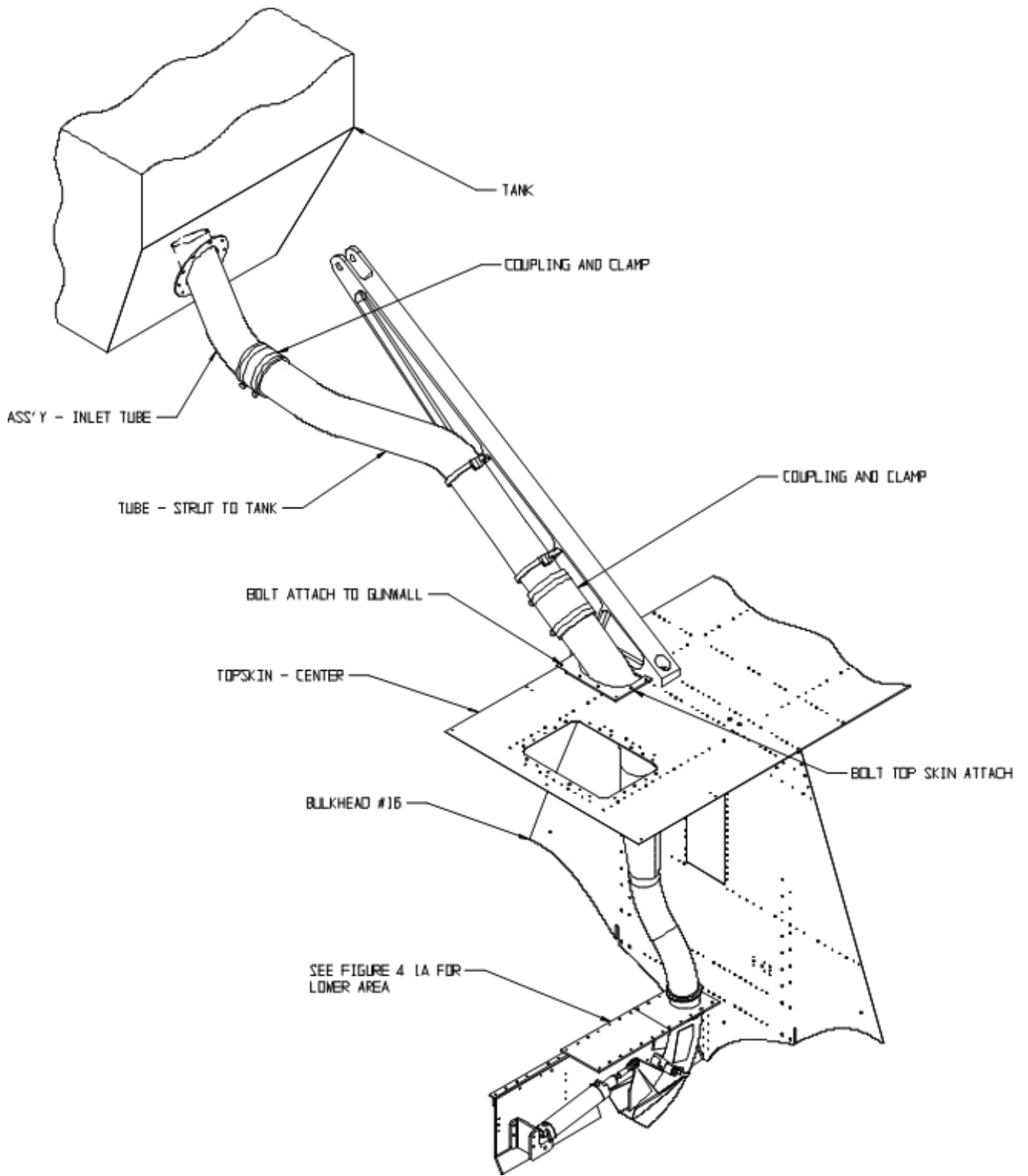

FIGURE 4.1A ASSEMBLY – SCOOPING SYSTEM - COMPLETE

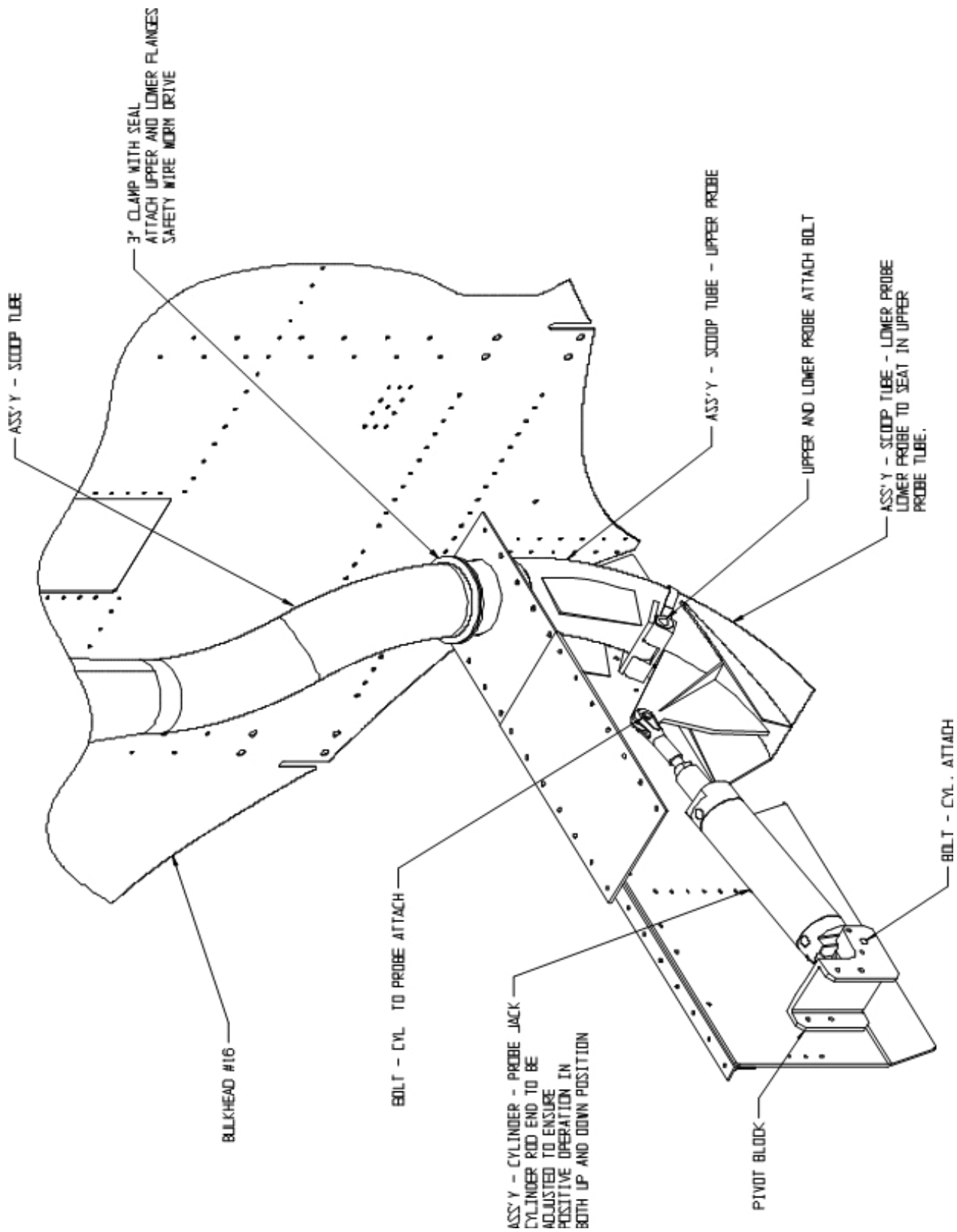

FIGURE 4.1B ASSEMBLY - SCOOPING SYSTEM

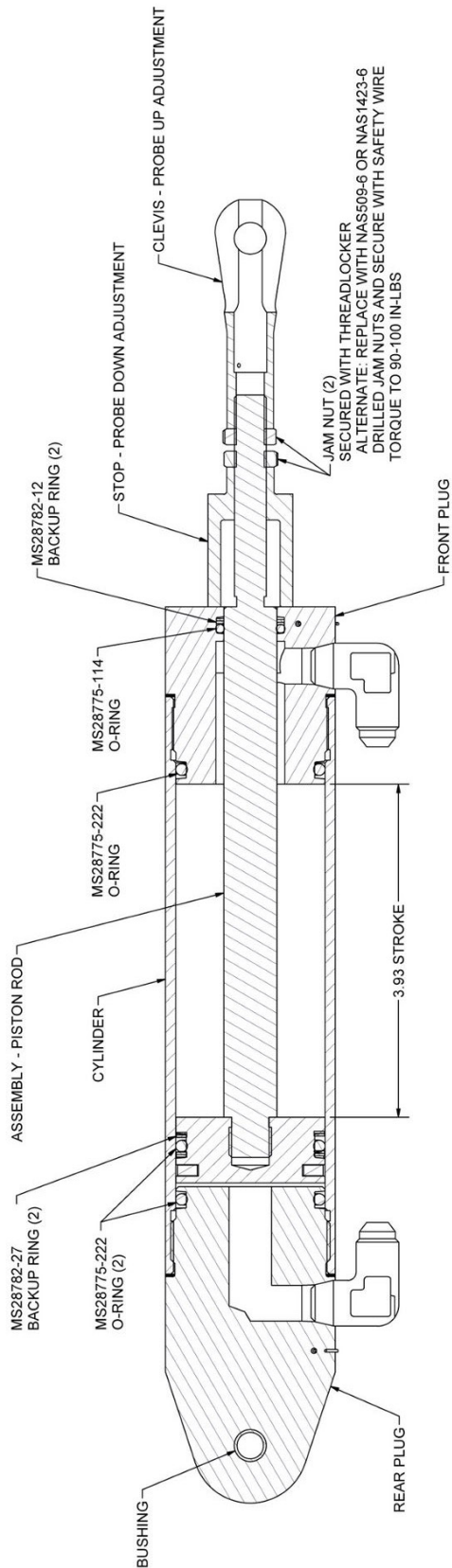

FIGURE 4.2A ASSEMBLY – CYLINDER PROBE JACK

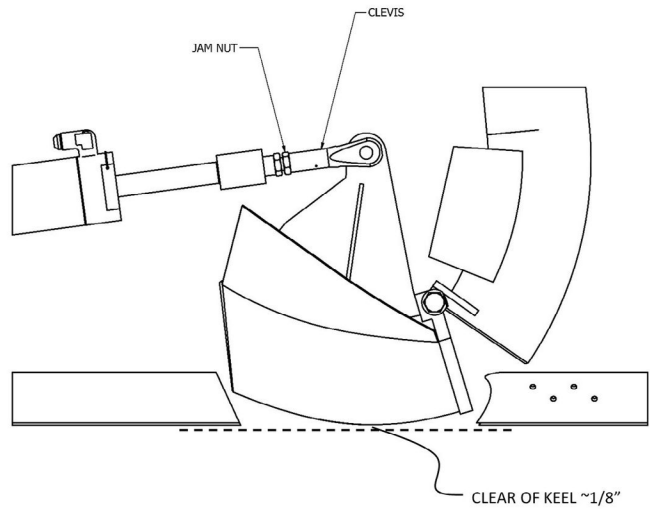

FIGURE 4.2B – PROBE UP POSITION ADJUSTMENT

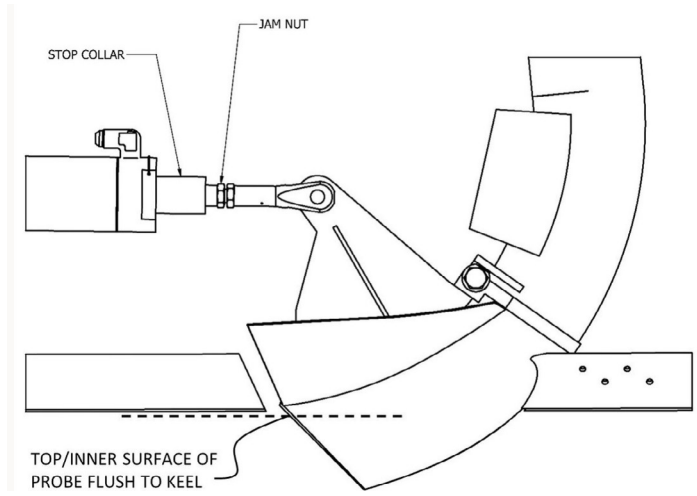

FIGURE 4.2C – PROBE DOWN POSITION ADJUSTMENT

CHAPTER 5 FOAM DELIVERY SYSTEM OPERATION, REMOVAL AND SERVICE

CONTENTS

5.1 DESCRIPTION AND OPERATION.....	62
5.2 ADJUSTMENT AND TEST	62
5.3 REMOVAL OF FOAM SYSTEM.....	62
5.4 SERVICE – FOAM SYSTEM	62

CHAPTER 5 - FOAM DELIVERY SYSTEM OPERATION, REMOVAL AND SERVICE

5.1 DESCRIPTION AND OPERATION

Full operating information of the entire foam system is described in Introduction Section 1.7. The foam system schematic is shown in Figure 5. The main 18 gallon firewall foam tank that feeds the hoppers is stock Air Tractor system. The 18 gallon firewall tank has been modified to allow foam from the float tanks to refill that tank. A fluid level gauge also has been added. Each float has a 30 gallon tank that pumps into the firewall tank.

5.2 ADJUSTMENT AND TEST

No adjustment is necessary for this system. When pumps are running a 'pump-on' light is located on the auxiliary instrument panel.

5.3 REMOVAL OF FOAM SYSTEM

To remove tank from float, disconnect electrical plug and hose coupling from tank edges. Lift from center handle and the tank from the float through top deck. Tank should have small amount of foam in for ease of removal. The tank floor may now be removed through top deck. The 18 gallon firewall tank is a standard Air Tractor installation with a Wipaire liquid level sensor added and line routed to the float tank.

5.4 SERVICE – FOAM SYSTEM

The foam pump on each float tank is not serviceable and cannot be overhauled. The float sensor in the 18 gallon tank also is not serviceable. Check lines for leaks and condition. Refer to Air Tractor manual for tank to hopper pump information.

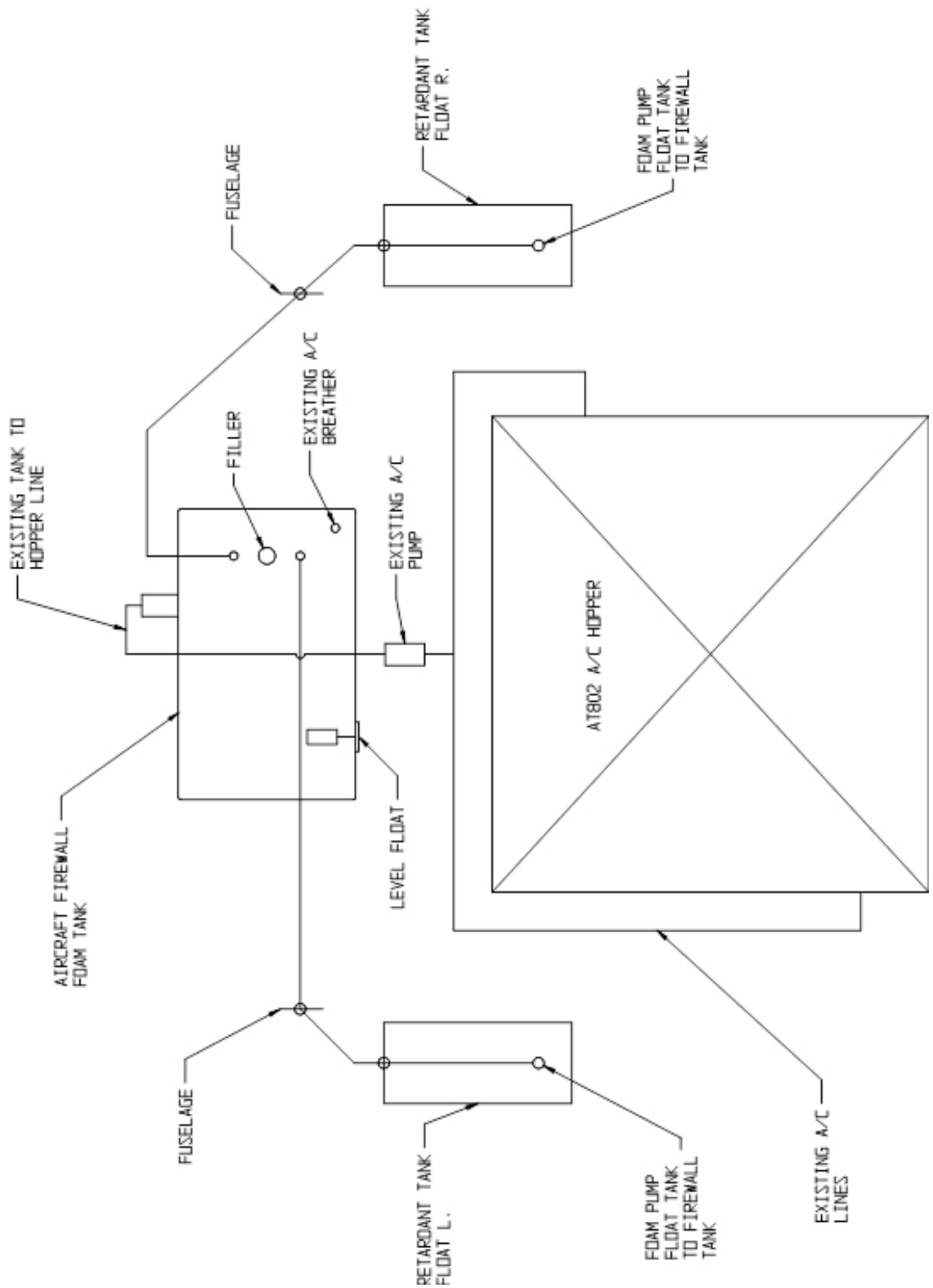

FIGURE 5.1 SCHEMATIC – PLUMBING – FOAM SYSTEM

THIS PAGE INTENTIONALLY LEFT BLANK

CHAPTER 6 FLOAT BILGE SYSTEM OPERATION, REMOVAL AND SERVICE

CONTENTS

6.1 DESCRIPTION AND OPERATION.....	66
6.2 ADJUSTMENT AND TEST	66
6.3 REMOVAL OF THE SYSTEM	66
6.4 SERVICE – BILGE SYSTEM	66

CHAPTER 6 - FLOAT BILGE SYSTEM OPERATION, REMOVAL AND SERVICE

6.1 DESCRIPTION AND OPERATION

Each float is equipped with (2) bilge pumps. These pumps are located in float compartments just forward of the step. These pumps are accessible through the inspection covers on each float side just forward of the step. In the event of leakage of the float hull, adjacent to the probe, these pumps will automatically pump water overboard in that float compartment. Also, in that float compartment, a water sensor indicator is located. When this indicator senses water, a light on the auxiliary instrument panel will light.

6.2 ADJUSTMENT AND TEST

No adjustment is necessary for this system. When pumps are operating. A light for the right float and left float will illuminate on the auxiliary instrument panel. When water is present in the float compartment forward of the step, the sensor will illuminate a light on the auxiliary instrument panel.

6.3 REMOVAL OF THE SYSTEM

To remove pumps from the float, remove access covers on each float side just forward of the step and remove pumps. Two pumps are located in each float.

6.4 SERVICE – BILGE SYSTEM

The bilge pumps are not serviceable and cannot be overhauled. Be sure pumps are not plugged and free of debris. Check all hoses for obstructions and condition. Check that the pump on lights are working. Submerge water sensor in water to check for light operation.

CHAPTER 7 VENT AND OVERFILL PROTECTION SYSTEM

CONTENTS

7.1 DESCRIPTION AND OPERATION.....	68
7.2 ADJUSTMENT AND TEST	68
7.3 SERVICE OVERFILL VENT SYSTEM	68

CHAPTER 7 - VENT AND OVERFILL PROTECTION SYSTEM

7.1 DESCRIPTION AND OPERATION

On the top aircraft hopper door, aft side, is a domed shaped overfill relief door. This door is hinged and spring loaded to blow open in the event of a tank overfill. The spring tension is pre-set by cable length. To open the door by hand, release the handle from its holder and pull forward to release the stop from its holder and let the cable go slack. The door is now free to hinge. To reattach, pull cable forward so cable ball is in its holder and stow handle.

7.2 ADJUSTMENT AND TEST

No adjustment is necessary for this system. The cable lengths determine the pressure on the spring. It should unseat at approximately 40 pounds of force.

7.3 SERVICE OVERFILL VENT SYSTEM

No service is necessary except to examine the condition of the cables, canvas defector, and all other parts.

CHAPTER 8 FLOAT STEERING AND RETRACT SYSTEM

CONTENTS

8.1 DESCRIPTION AND OPERATION.....	70
8.2 ADJUSTMENT	70
8.3 REMOVAL AND ACCESS	70
8.4 SERVICE OF STEERING AND RETRACT SYSTEM	70

CHAPTER 8 - FLOAT STEERING AND RETRACT SYSTEM

8.1 DESCRIPTION AND OPERATION

The water rudder retract system is manually operated by a lever in the cockpit. The water rudder is then operated by a system of cables and pulleys. Steering is directed from the aircraft steering system. See Figure 8 for retract and steering schematic.

8.2 ADJUSTMENT

Rigging of the water rudder steering cables is accomplished by centering the aircraft rudder and adjusting the turnbuckles such that both rudders trail with the float centerline. Set steering and balance cable tension to 10 lbs +5/-0. Retraction cables should be rigged such that the rudder blade is in the up position and that the cables are just slack in the down position and lightly resting on the stops.

8.3 REMOVAL AND ACCESS

Cables can be accessed through the fuselage side panels, aft trailing edge of pylon, and through top float inspection covers.

8.4 SERVICE OF STEERING AND RETRACT SYSTEM

The pulley bearing on both systems are sealed and not serviceable. Inspect condition of all pulleys and cables for wear every 100 hours and replace as necessary.

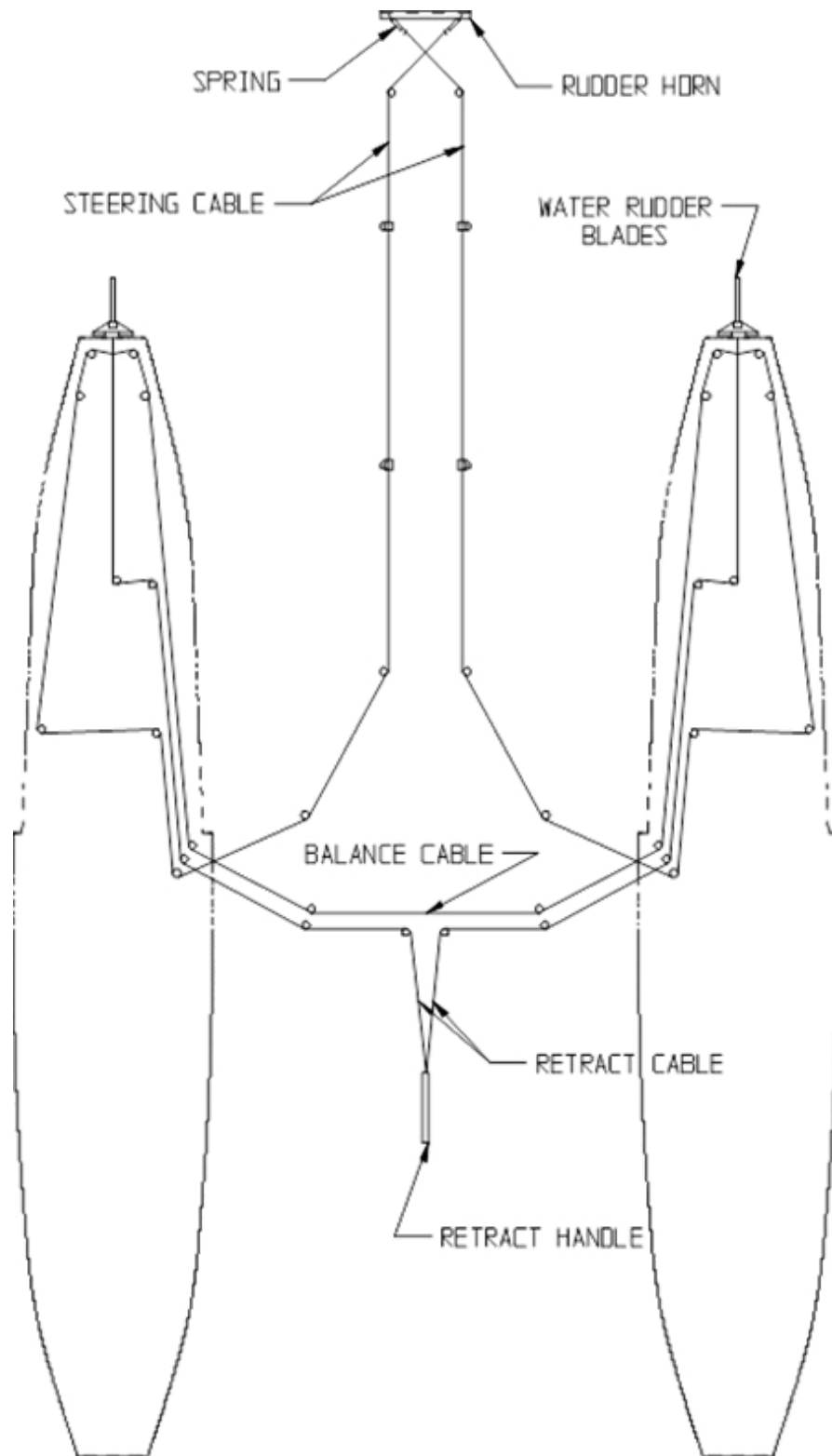

FIGURE 8.1 WATER RUDDER STEERING AND RETRACTION SYSTEM

THIS PAGE INTENTIONALLY LEFT BLANK

CHAPTER 9 ANGLE OF ATTACK SYSTEM

CONTENTS

9.1 GENERAL.....	74
9.2 MAINTENANCE.....	74

CHAPTER 9 – ANGLE OF ATTACK SYSTEM

9.1 GENERAL

The Rite Angle 111b AOA system is installed in this aircraft. A separate manual is provided for installation and operation of this system. This system is not a primary aircraft instrument and is for advisory only.

9.2 MAINTENANCE

The AOA system is pre-programmed for the AT-802A aircraft on 10000 floats. The wiring schematic is on Figure 9.4. The manual for all other instructions is in the manufacturer's manual.

The vane setting should be 7.8 ° nose up from aircraft leveling point when 1st green light just comes on. Measurements were taken from flat section of vane. Figure 9.4A shows resistances in ohms (Ω) across the P-12 connection on the J6 module box. These readings are approximates only and vary from installation to installation, however they provide a good reference for different flap settings in ensuring the flap sensor is calibrated.

CHAPTER 10 AIRCRAFT WING AND CONTROL SURFACE MODIFICATIONS

CONTENTS

10.1 VORTEX GENERATORS	76
10.2 FINLETS	76
10.3 ELEVATOR SERVO TAB	76

CHAPTER 10 - AIRCRAFT WING AND CONTROL SURFACE MODIFICATIONS

10.1 VORTEX GENERATORS

The wing leading edge and the leading edge of the horizontal stabilizers have vortex generators installed. Each wing leading edge has 63 generators and each horizontal stabilizer has 21 generators. If one falls off, replace it according to the drawing instructions. Inspect wings and horizontal tail for missing vortex generators. No two adjacent generators may be missing on any wing or horizontal stabilizer. Any missing generators must be replaced as soon as possible.

10.2 FINLETS

The horizontal stabilizer is modified for the installation of vertical finlets. Each stabilizer has 2 finlets, one on the topside and one on the lower side (total of 4 per aircraft). Two methods of attachment have been used; the method of attachment can be determined by the access provisions. Finlets without support fittings (attached with radius plates and nutplates) use a rectangular access panel, located under the lower finlets. Finlets attached with support fittings have an oval access panel, located inboard of the lower finlet and a circular access panel under the leading edge of the lower finlet. Refer to Service Letter 253 for additional maintenance instructions.

Finlets Without Support Fittings

Perform a visual inspection every 50 hours of the finlets and support struts, if installed. Clean the area; inspect finlets for missing gaskets and loose bolts or cracks in attach fittings; if struts are installed, inspect the strut and attach fittings for loose bolts or cracks; inspect the area of the stabilizer around mounting holes and doublers for cracks or loose rivets. It is acceptable to remove small portions of the finlet side skins or sealant adjacent to the attach fittings to enable visual inspection of the fitting.

Remove and inspect the finlets every 100 hours. Remove the lower finlet and strut, if installed, to expose rectangular access panel. Remove panel and inspect forward and aft attach points as well as spar flange radius for cracks and corrosion. Remove upper finlet and strut, if installed. Inspect all finlets, struts and attach fittings for cracks, corrosion, loose rivets, or other un-airworthy conditions.

Finlets With Support Fittings

Refer to Section 16.5 for annual inspection and torque check of the finlet attachment. Refer to Section 16.6 for 1500 hour inspection of the horizontal stabilizer spar and front support fittings.

10.3 ELEVATOR SERVO TAB

The elevator servo tab has been modified to add 1.0 inch to the chord of the tab. Inspect elevator servo tab extension for condition and security.

CHAPTER 11 AUXILIARY INSTRUMENT PANEL

CONTENTS

11.1 DESCRIPTION AND OPERATION	78
--------------------------------------	----

CHAPTER 11 - AUXILIARY INSTRUMENT PANEL

11.1 DESCRIPTION AND OPERATION

An auxiliary instrument is mounted on top of the landplane instrument panel. This panel houses all the switches, lights, and displays for the water scooping portion of this installation.

This panel also houses the ITT and Torque gauges for easier viewing. Figure 11.1 and 11.2 shows the panel layout along with the circuit breaker panel layout.

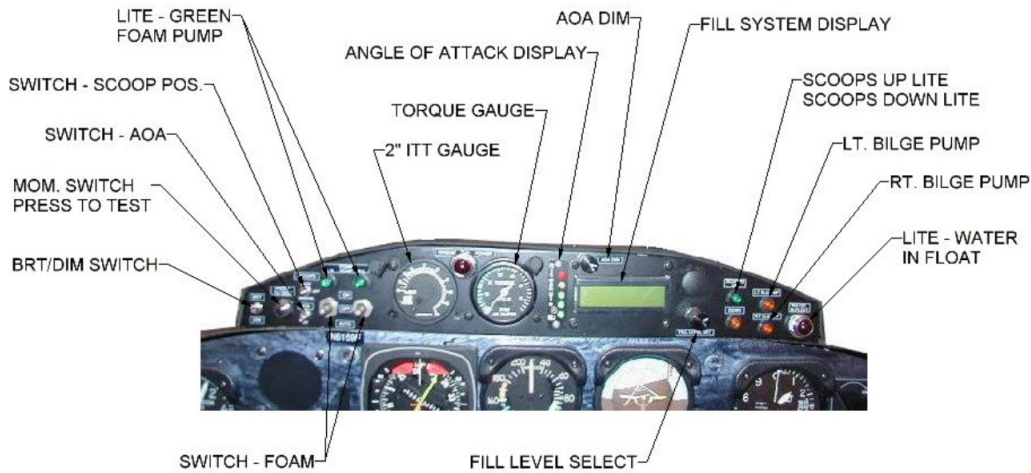

THIS PANEL FOR AIR TRACTOR
 S/N 172 AND LOWER



THIS PANEL FOR AIR TRACTOR
 S/N 173 AND UP

FIGURE 11.1 INSTRUMENT PANEL

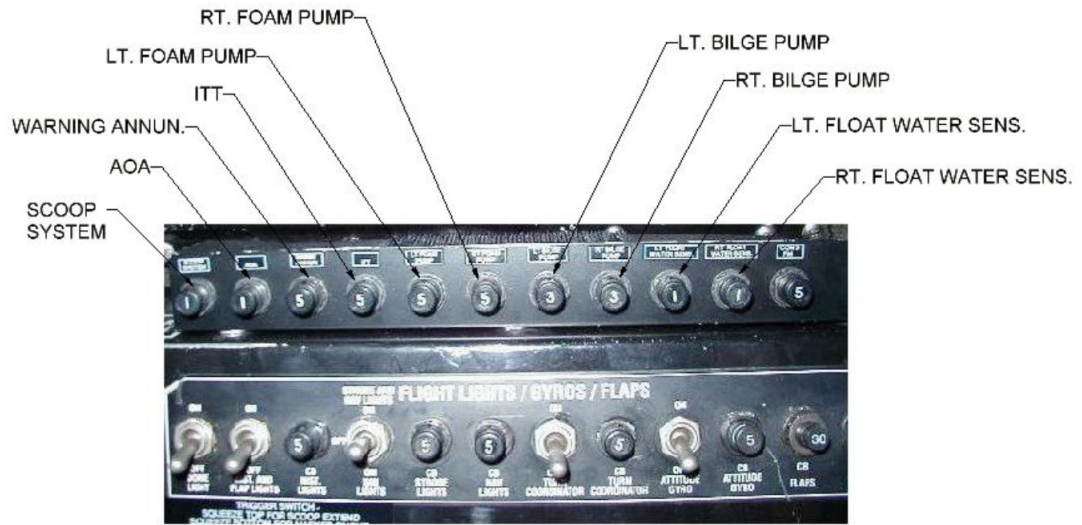

FIGURE 11.2 INSTRUMENT PANEL (CIRCUIT BREAKER)

THIS PAGE INTENTIONALLY LEFT BLANK

CHAPTER 12 ELECTRICAL

CONTENTS

12.1 GENERAL.....	82
-------------------	----

CHAPTER 12 - ELECTRICAL

12.1 GENERAL

Figures 12.1 through 12.11 show the electrical schematic for the auxiliary instrument panel along with electrical schematics for each noted system.

SCHEDULE - PANEL LITES & SWITCHES

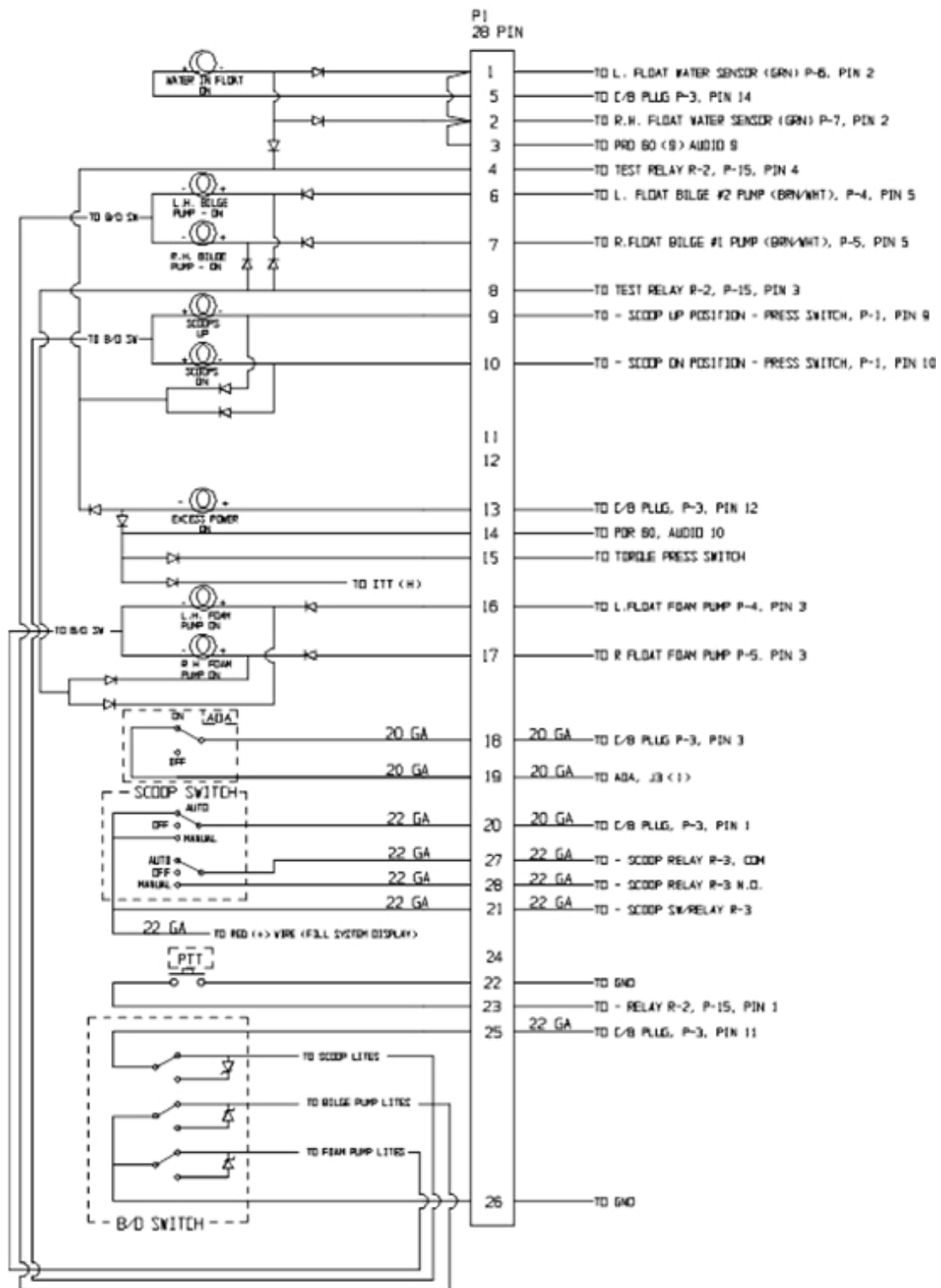

FIGURE 12.1 SCHEMATIC – AUXILIARY INSTRUMENT PANEL

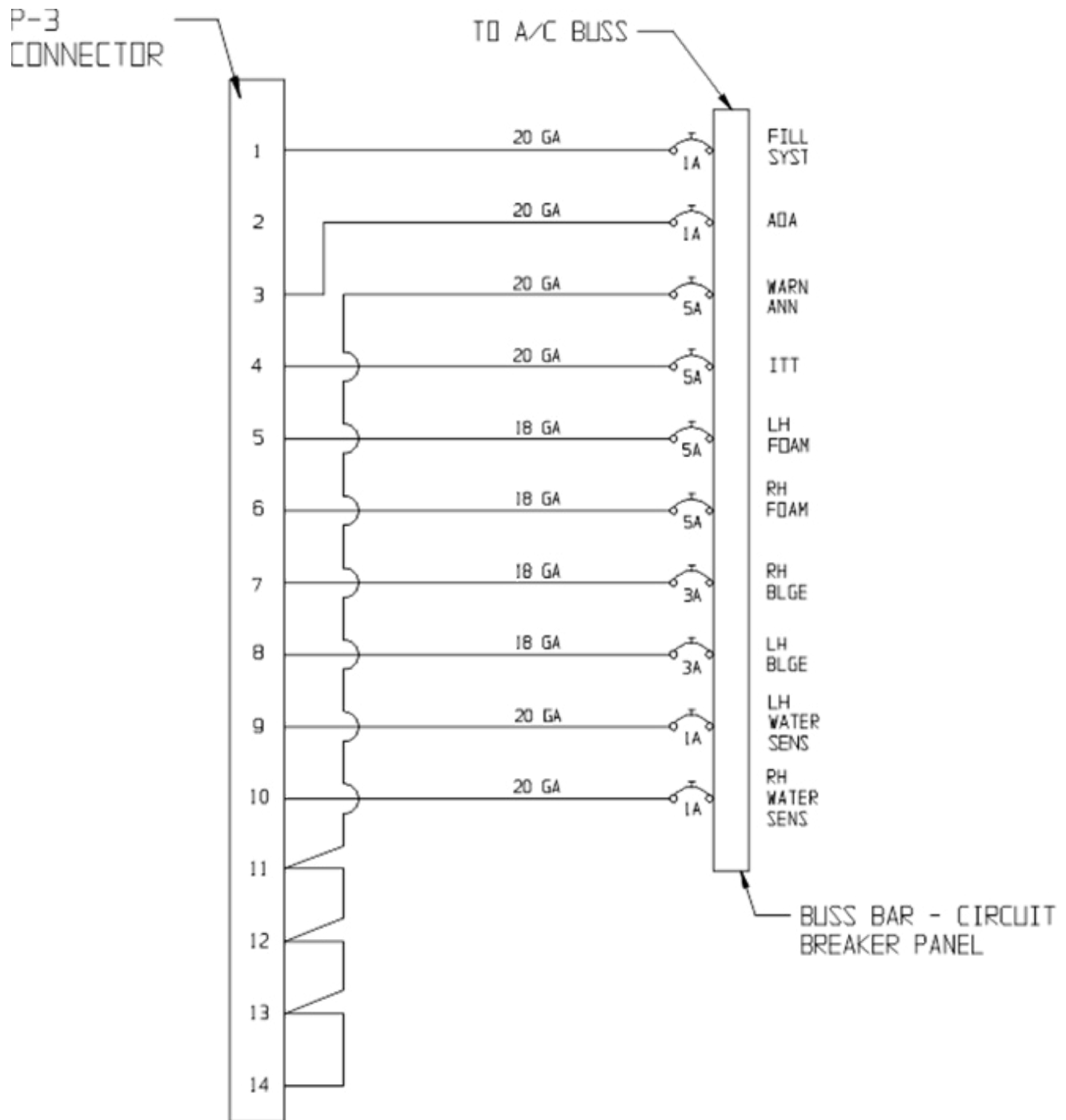

FIGURE 12.2 SCHEMATIC – CIRCUIT BREAKER PANEL

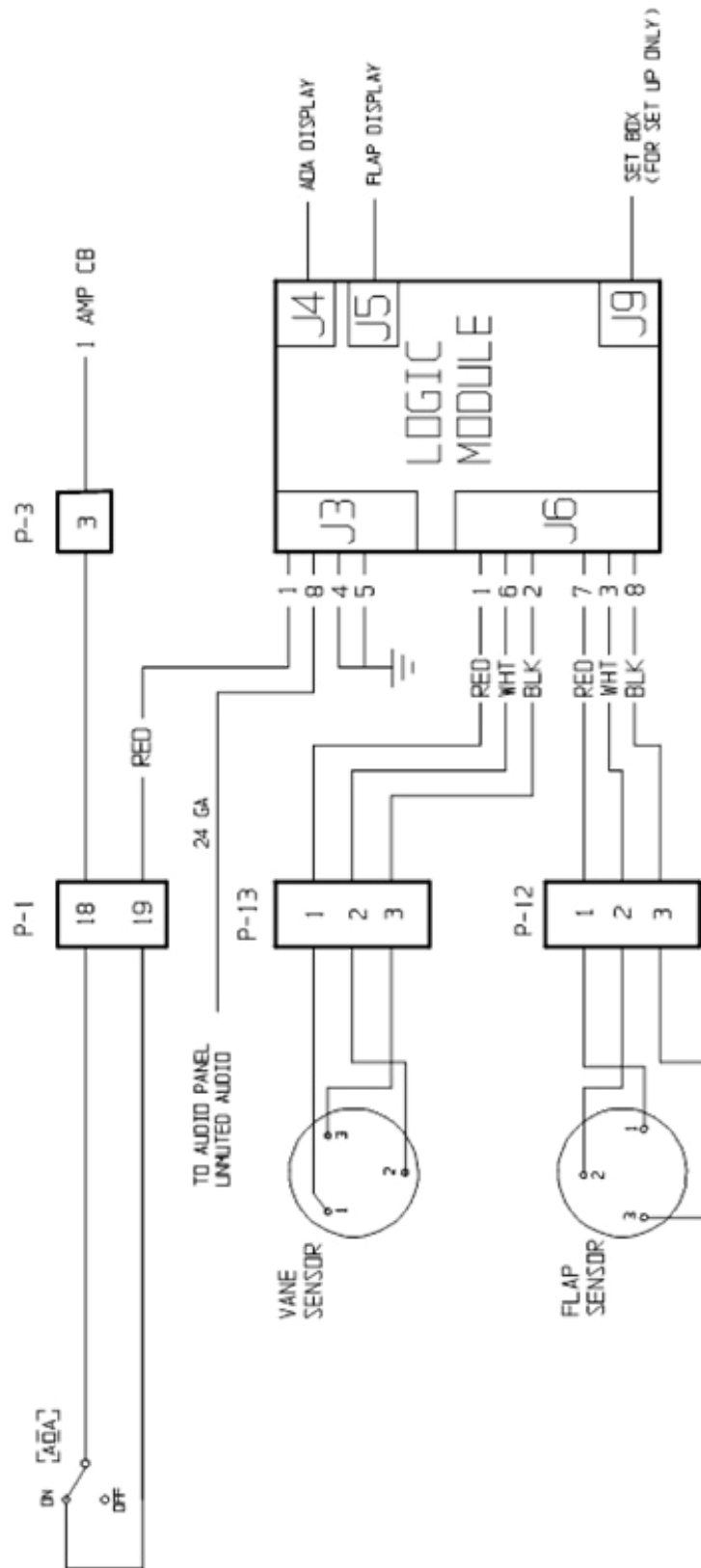
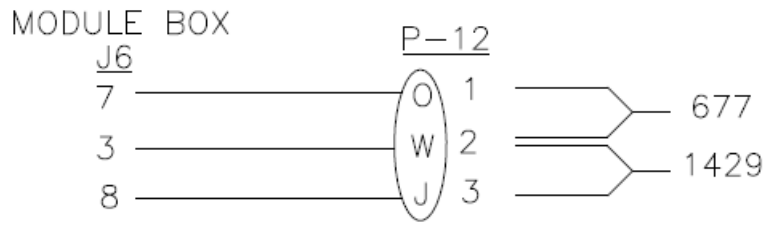
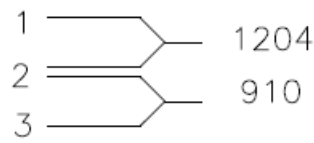

FIGURE 12.3 SCHEMATIC – INSTALLATION – ANGLE OF ATTACK

FLAP SENSOR



FLAPS UP



FLAPS 9.4°

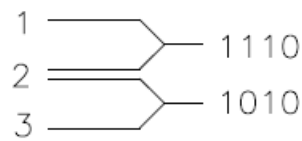

FLAPS 18.6°

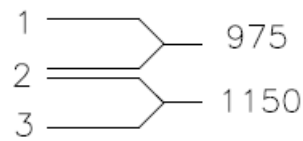

FLAPS 28.4°

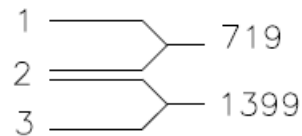

FIGURE 12.4 AOA FLAP CALIBRATION READINGS

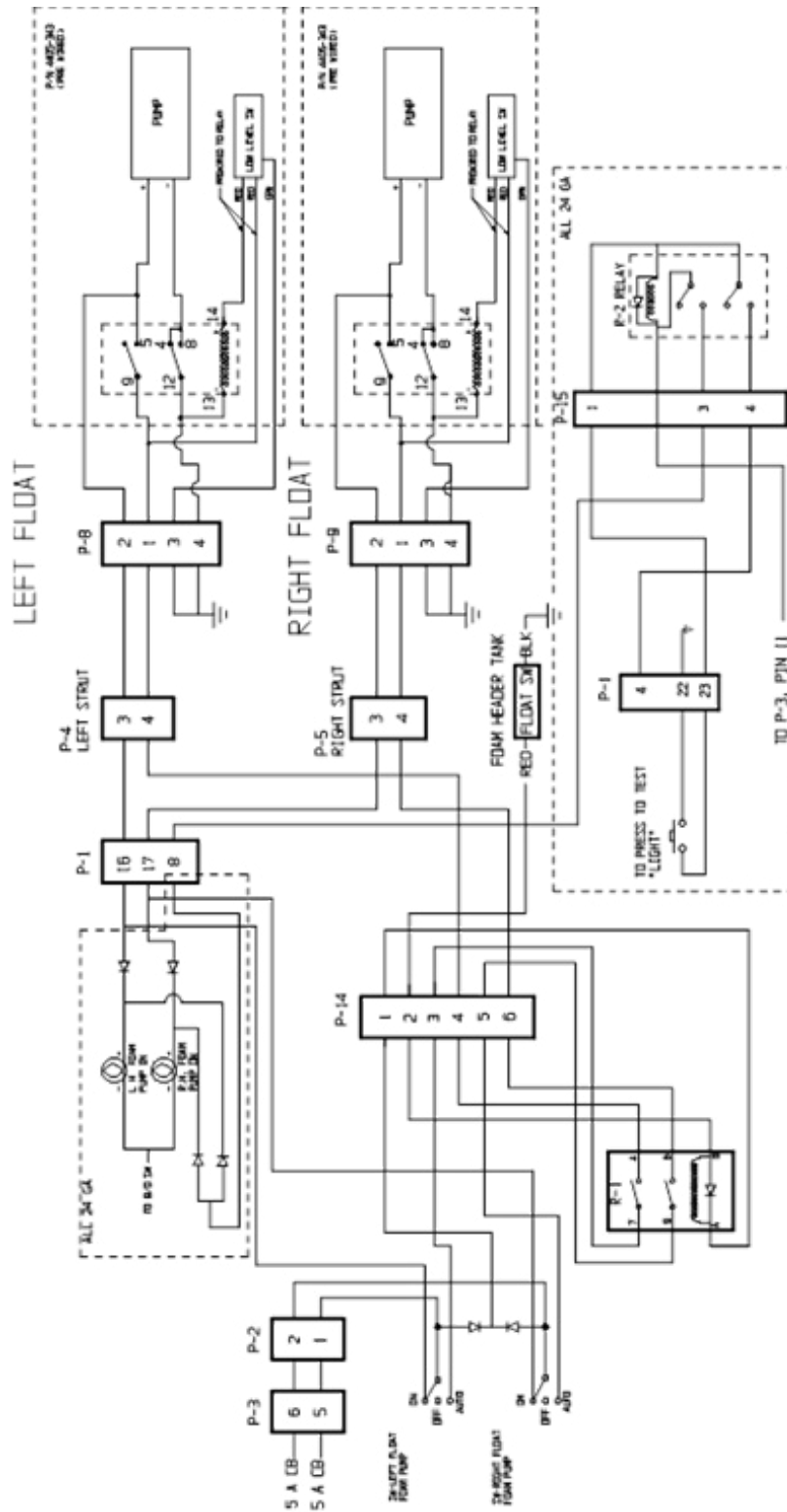

FIGURE 12.5 SCHEMATIC – INSTALLATION – FOAM TANKS/PUMPS

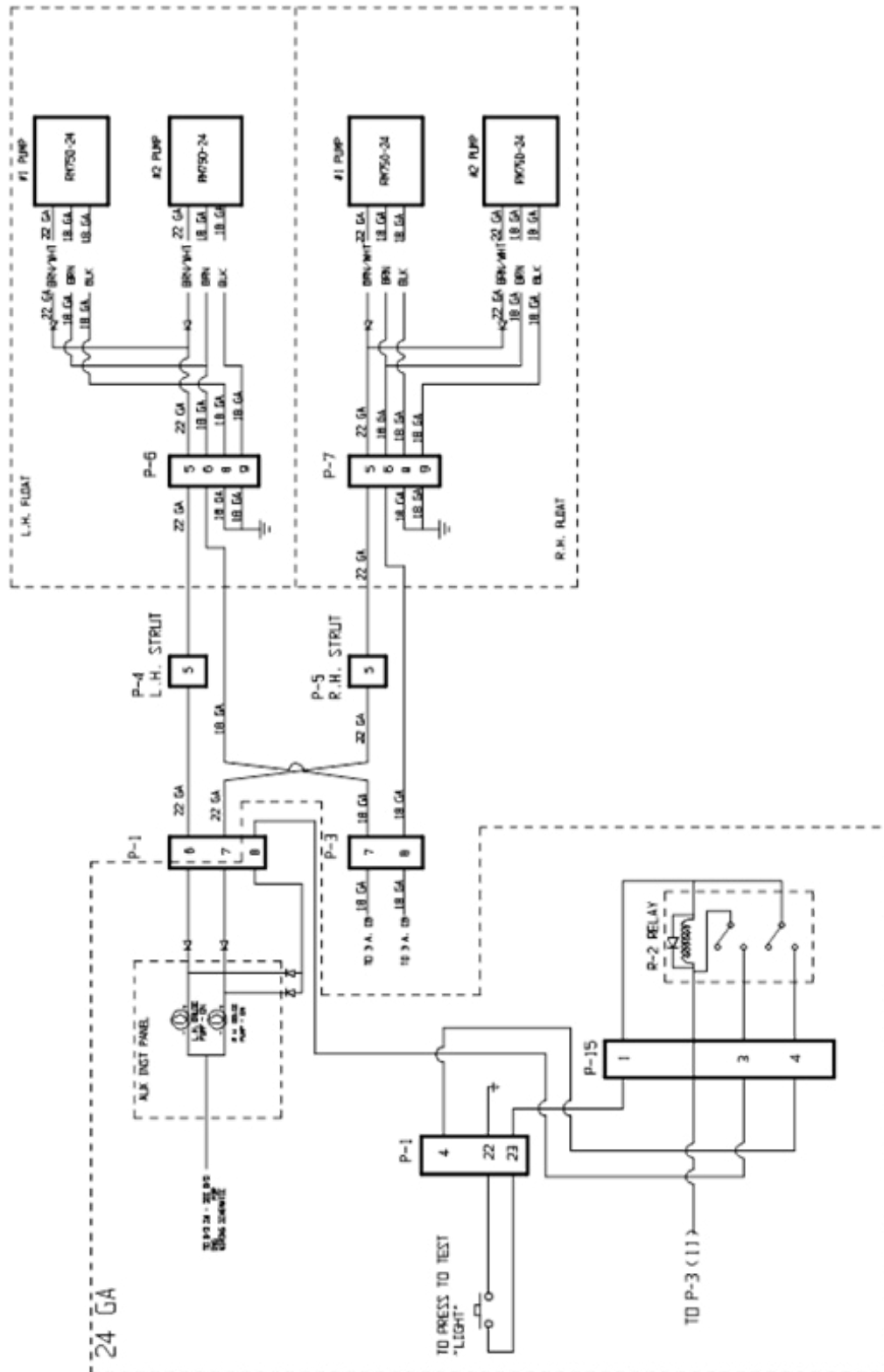

FIGURE 12.6 SCHEMATIC – INSTALLATION – BILGE PUMPS

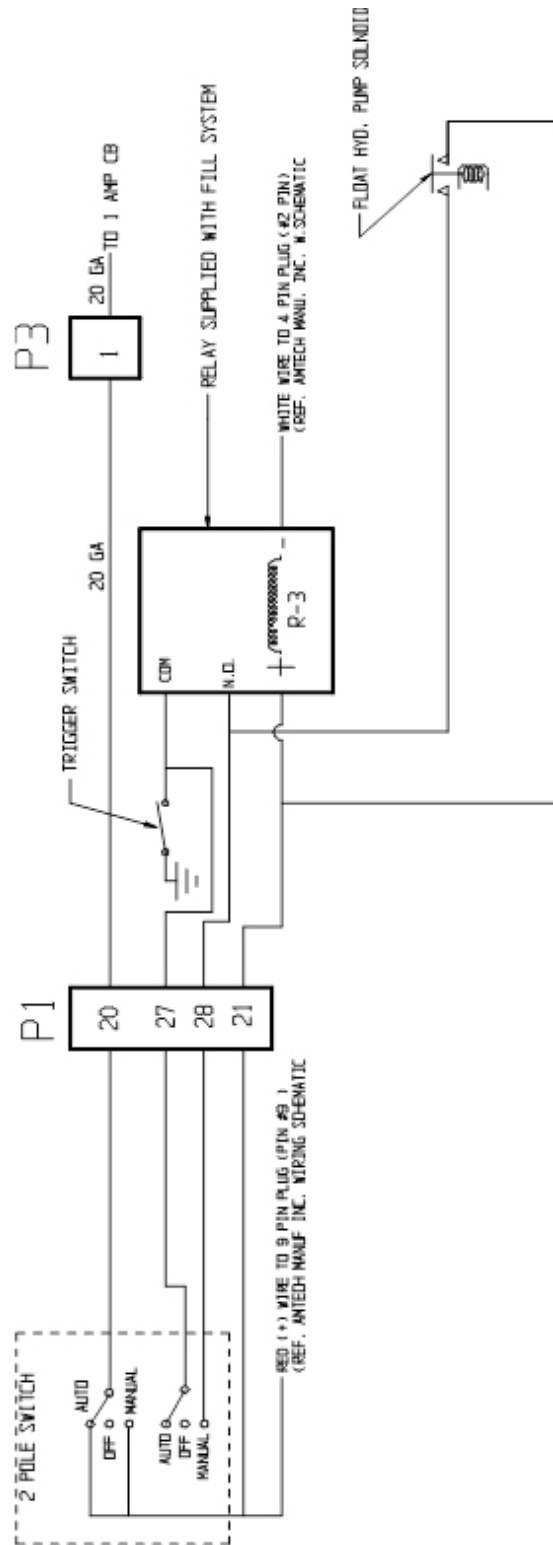

FIGURE 12.7 SCHEMATIC – INSTALLATION – SCOOP/FILL SYSTEM

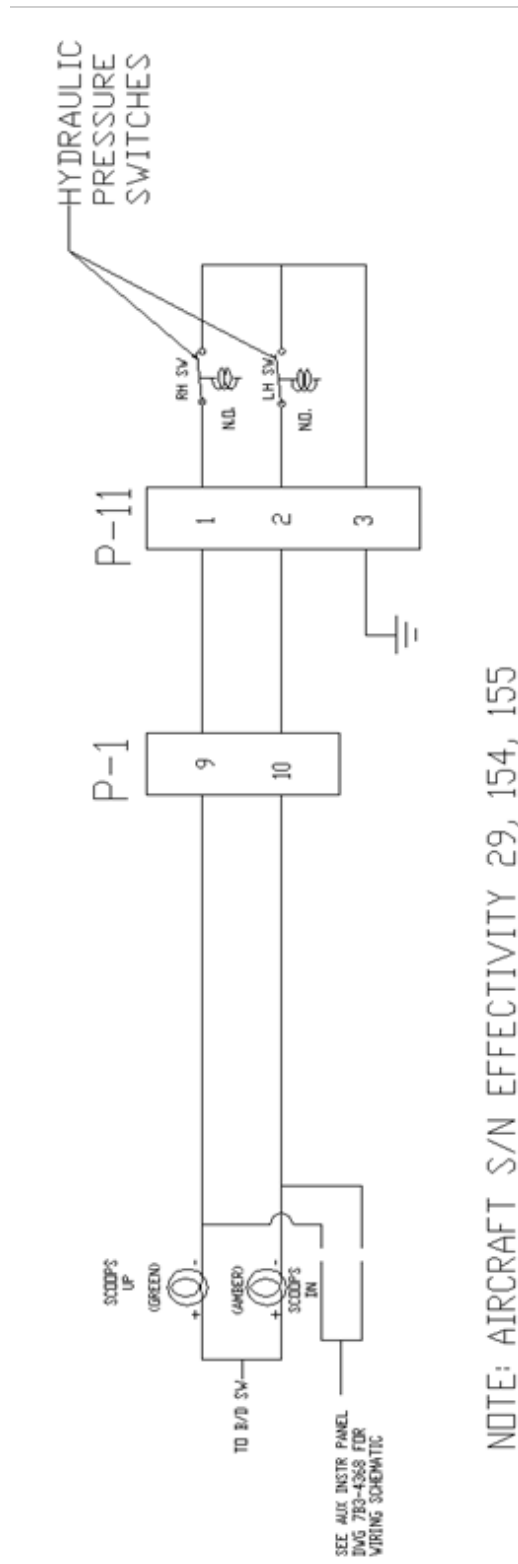

FIGURE 12.8 SCHEMATIC – INSTALLATION – PROBE POSITION

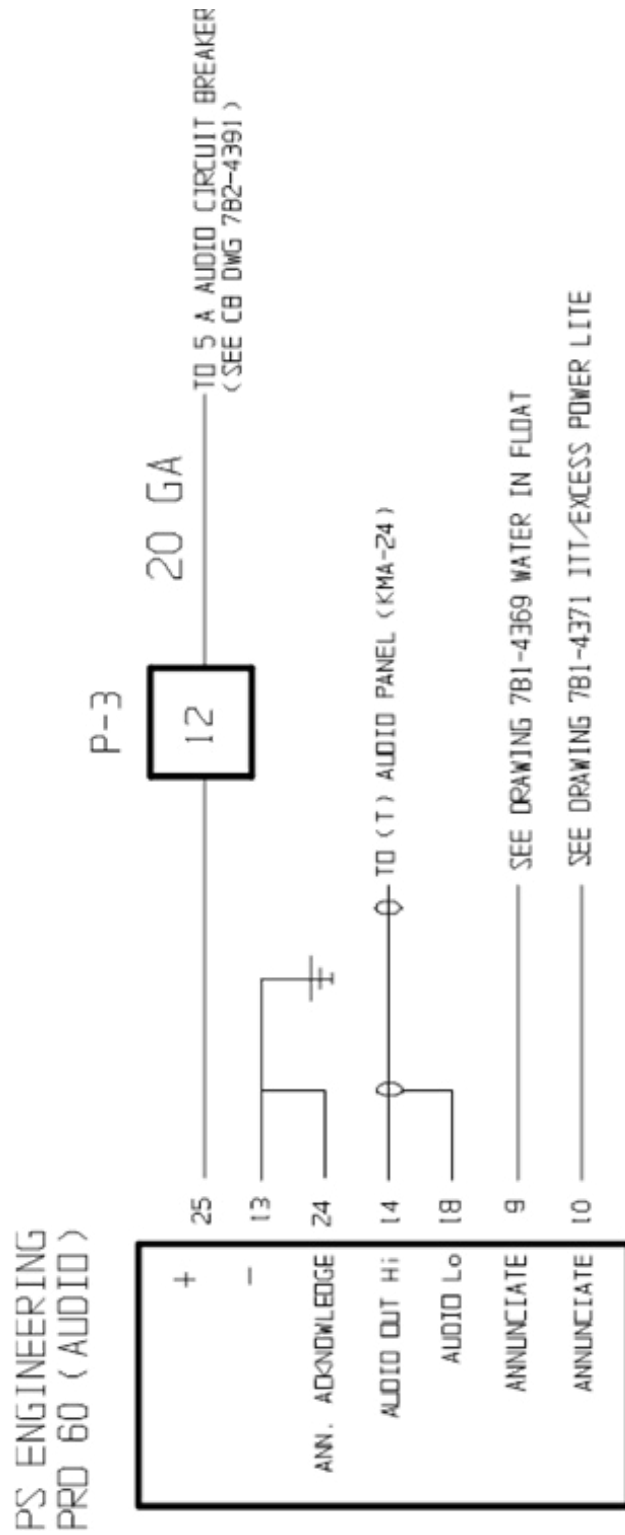

FIGURE 12.9 SCHEMATIC – INSTALLATION – PDR 60 AUDIO

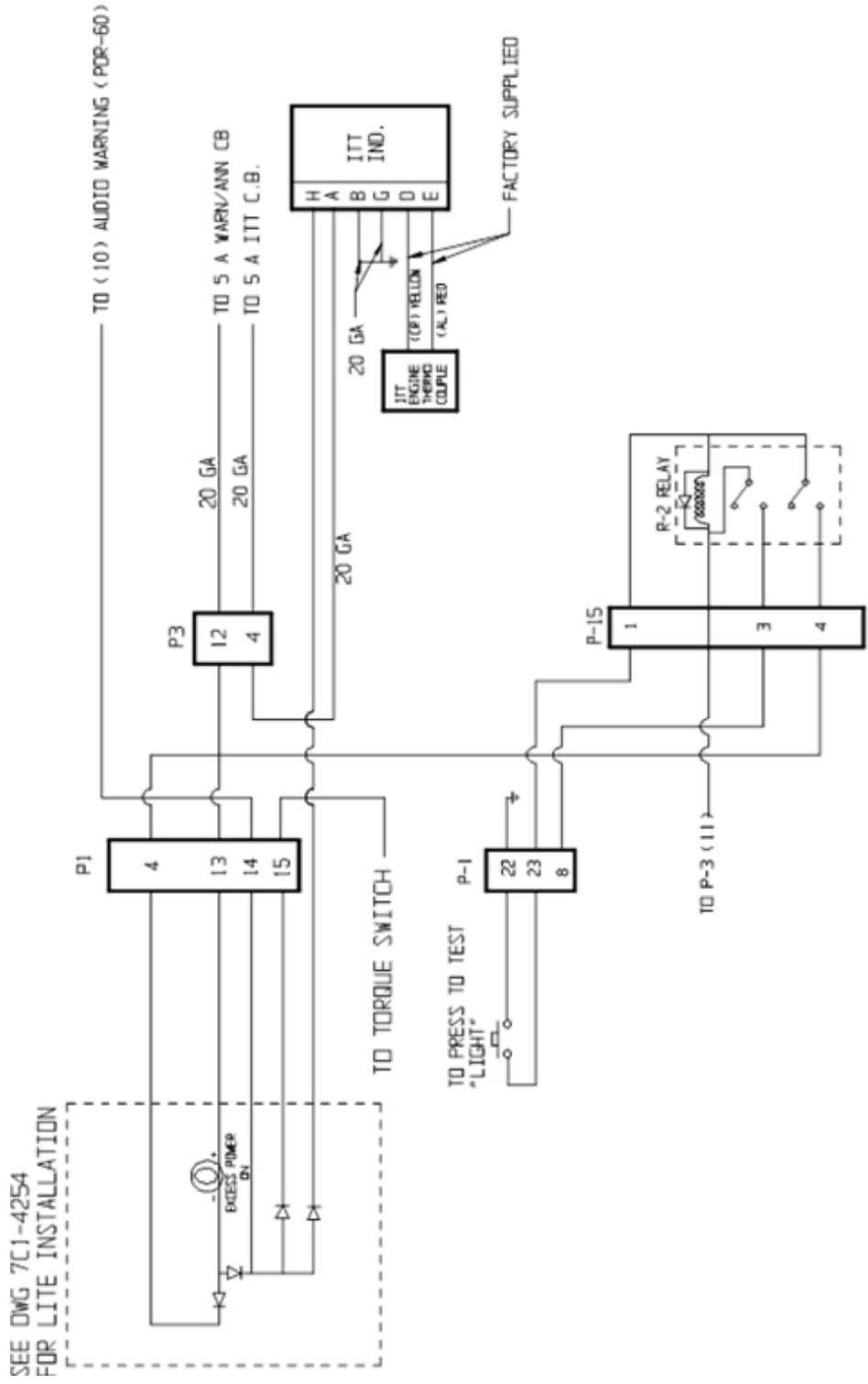

FIGURE 12.10 SCHEMATIC – INSTALLATION – ITT / EXCESS POWER LIGHT

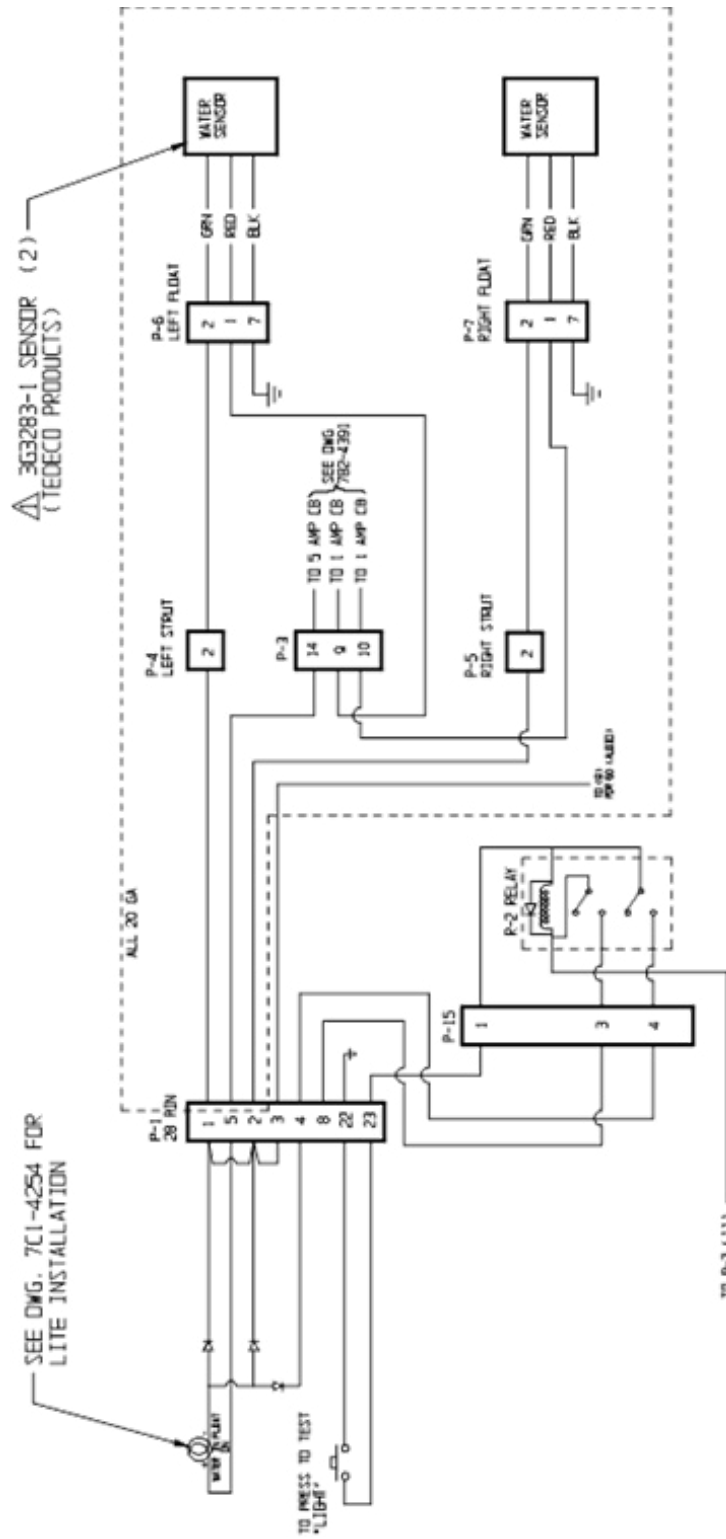

FIGURE 12.11 SCHEMATIC – INSTALLATION – WATER IN FLOAT SENSORS

THIS PAGE INTENTIONALLY LEFT BLANK

CHAPTER 13 REPAIRING FLOAT HULL SHEET METAL, BULKHEADS AND OTHER AREAS

CONTENTS

13.1 GENERAL.....	96
-------------------	----

CHAPTER 13 - REPAIRING FLOAT HULL SHEET METAL, BULKHEADS AND OTHER AREAS

13.1 GENERAL

For all float skin and extrusion structural repairs, refer to Wipaire's Structural Repair Manual (SRM) part number 1008274.

CHAPTER 14 GENERAL SERVICING

CONTENTS

14.1 SERVICE SCHEDULE	98
14.2 LUBRICATION AND CORROSION PROTECTION	99
14.3 BOLT TORQUES	100

CHAPTER 14 - GENERAL SERVICING

14.1 SERVICE SCHEDULE

As provided by the Time and Maintenance Checks Chapter, there are items to be checked each 25, 50, 100 hours and annual. Also there are notes on special items which may require servicing at more frequent intervals.

- When conducting an inspection at 25 hours, all items marked for 25 hours would be accomplished.
- When conducting an inspection at 50 hours, the 25 and 50-hour items would be accomplished.
- When conducting an inspection at 100 hours, the 25, 50, and 100-hour items would be accomplished.
- When conducting an annual inspection, the 25, 50, 100, and annual items would be accomplished.

As a general inspection guidelines, address the following areas during inspection:

Bolts

Inspect bolts for condition and security. Use correct torque during installation; when visual inspection indicates a need, check torque. Specific and general torques are given by Section 14.3. Section 16.4 provides a checklist for recommended replacement times and torque checks for critical bolts.

Fluid Lines and Hoses

Inspect fluid lines and hoses for leaks, cracks, dents, kinks, chafing, security, corrosion, and deterioration.

Metal Parts

Inspect metal parts for security of attachment, cracks, metal distortion, broken welds, corrosion, paint condition, and any other apparent damage.

Movable Parts

Inspect movable parts for security of attachment, binding, excessive wear, safetying, proper operation, proper adjustment, correct travel, cracked fittings, security of hinges, defective bearings, cleanliness, corrosion, deformation, sealing, and tension. Lubricate all movable parts per Section 14.2.

Wiring

Inspect wiring for security, chafing, burning, defective insulation, loose or broken terminals, corroded terminals.

Some additional general maintenance areas are as follows:

Electrical Connections

Use Molycote 4 (DC4) when installing connectors and terminals. Apply SP-400 or LPS 500 over electrical connections to prevent corrosion.

Hydraulic Fluid

Use MIL-H-5606 fluid for all hydraulic systems, including brakes.

Joints

Spray all joints with light penetrating oil such as LPS 3 to ensure lubrication.

Nose and Main Gear Tracks

Clean and lubricate with grease. Check for excessive track wear as described in Section 2.3

14.2 LUBRICATION AND CORROSION PROTECTION

The following products are recommended for lubrication and corrosion protection of the float hulls, amphibious components, and firebombing equipment. This lists the products used by Wipaire during assembly of the floats.

NOTE: Equivalent products may provide satisfactory corrosion protection. If using other products, to inspect frequently so as to determine their effectiveness.

Corrosion Protection of Nuts, Bolts, Hydraulic Lines and Metal Surfaces

Ardrox AV30 - Chemetall

CRC SP400 - CRC Industries

Additional Corrosion Protection

Boeshield T9 - PMS Products

ACF-50 - Lear Chemical

Tef-Gel - Ultra Safety Systems

CorrosionX - Corrosion Technologies

General Lubricants

LPS 1, LPS 2 and LPS 3 - ITW Pro Brands

LPS Dry Film - LPS Industries

Wheel Bearings & Pivot Points With Grease Ports

NOTE: If existing grease cannot be identified lubri-flush all float grease fittings until visibly exhausting all old grease and only new grease is present. Additionally the existing grease used in wheel bearings cannot be determined, completely clean and repack bearings with new grease.

HCF Grease (P/N 605) - BG Products

Aeroshell Grease 22 - Shell Global

Green Grease - Omni Lubricants

Mobil Aviation Grease SHC 100 - ExxonMobil Aviation

Aeroshell Grease 64 (Nose Pivot Block Only) - Shell Global

Float Sealant

PS 890 B-2 or B-4 - PPG Aerospace PRC-DeSoto

PR 1422 B2, B4 or B6 - PPG Aerospace PRC-DeSoto

PR 1440 C - PPG Aerospace PRC-DeSoto

GE500 - Henkel

RTV108 or 157 - Momentive

SIKAFLEX 201 or 252 - Sika Corporation

Electrical Insulating Compound

Molycoat 4 (DC4) - DuPont

Brake Caliper Grease

CRC 1003791 - CRC Industries

14.3 BOLT TORQUES

NOTE: Fastener length may vary due to design changes in adjacent parts; torque limits still apply.

In the absence of any preempting data such as that found on installation drawings, use the SPECIFIC TORQUE table below for the listed fasteners. If the nut and bolt torque is not included in the SPECIFIC TORQUE table and has no torque value provided on an associated installation drawing or service letter, use AC43.13-1B standard torque value tables shown below.

Use caution when tightening bolts in shear that are subject to rotational movement. The nut should be run down to washer or bearing surface snugly and must NOT be over torqued. Over torquing may cause deformation of the connection to a degree likely to result in binding or unnecessary wear.

SPECIFIC TORQUE LIMITS

ASSEMBLY P/N	DESCRIPTION	FASTENER P/N	TORQUE (IN-LBS)
7D1-4256	Front Saddle Bolt	NAS156-130	2400
	Rear Saddle Bolt	NAS154DH59	2400
	Inner Bolt, Upper Front Fuselage Fitting	NAS158A105	2400
	Front Kicker Strut Upper Bolt	AN7-26A	492
	Rear Kicker Strut Upper Bolt	NAS6209-26	492
	Rear Kicker Stut Lower Bolt	NAS6209-31	492
	Drag Strut to Float	MS20008-15	900
13A04000-127 (40-101)	Main Wheel Assembly (Cleveland)	AN4-40A	90
30-67C	Brake Assembly (Cleveland)	103-11700	85-90
13A06000-015 (40-426)	Nose Wheel Assembly (Cleveland)	AN5-35A	150
13A04000-127 (100-1024)	Main Wheel Assembly (Grove)	AN4-40A	90
13A04000-057	Main Gear Drag Link Assemblby Brake Torque Plate Bolts	MS16997-99	190
	Main Gear Drag Link Assemblby Lower Tube Bolts	AN7-13A	450
	Main Gear Drag Link Assemblby Upper Tube Bolts	AN8-14A	490
10A09000-293	Scoop Actuator Jamb Nut to Probe Stop	AN316-6R	90-100
1011359	Hydraulic Reservoir Sight Glass	MS21044N8	60

STANDARD TORQUES PER AC43.13-1B

TENSION APPLICATION - FINE THREAD		
NUT-BOLT SIZE	TORQUE LIMITS (IN-LBS)	
	MIN.	MAX.
8-36	12	15
10-32	20	25
1/4-28	50	70
5/16-24	100	140
3/8-24	160	190
7/16-20	450	500
1/2-20	480	690
9/16-18	800	1000
5/8-18	1100	1300
3/4-16	2300	2500

SHEAR APPLICATION - FINE THREAD		
NUT-BOLT SIZE	TORQUE LIMITS (IN-LBS)	
	MIN.	MAX.
8-36	7	9
10-32	12	15
1/4-28	30	40
5/16-24	60	85
3/8-24	95	110
7/16-20	270	300
1/2-20	290	410
9/16-18	480	600
5/8-18	600	780
3/4-16	1300	1500

NOTE: Reduce torque values by 20% if Tef-Gel is coating the bolt threads.

THIS PAGE INTENTIONALLY LEFT BLANK

CHAPTER 15 RESERVED

This chapter is intentionally left blank for chapter number standardization across multiple Wipaire service manuals.

THIS PAGE INTENTIONALLY LEFT BLANK

CHAPTER 16 TIME LIMITS & MAINTENANCE CHECKS

CONTENTS

16.1 INSPECTION TIME INTERVALS CHECKLIST	106
16.2 OVERWEIGHT / HARD LANDING INSPECTION CHECKLIST	109
16.3 GEAR UP LANDING INSPECTION CHECKLIST	111
16.4 FLOAT HARDWARE RETORQUE AND REPLACEMENT CHECKLIST	112
16.5 FINLET & ATTACHMENT	115
16.6 HORIZONTAL STABILIZER SPAR & FINLET SUPPORT FITTINGS.....	116

16.1 INSPECTION TIME INTERVALS CHECKLIST

Items denoted with () are considered preventative maintenance checks and can be completed and signed off by authorized personnel I.A.W. CFR 14 Part 43.3 and 43.7 and Appendix A subpart C, or equivalent CAA regulation

		Inspection Interval				Mechanic	
		25	50	100	Annual	Left	Right
Maintenance Checks							
A. General							
1.	Inspect placards for condition. Check for presence of required placards. (Refer to AFMS)				X		
B. Float Hulls, Struts & Rigging							
1.	Inspect float exterior for damage, corrosion, paint condition, etc.		X*	X	X		
2.	Inspect struts & attach fittings for damage, corrosion, etc.			X	X		
3.	Inspect spreader bars for damage, corrosion, etc.			X	X		
4.	Inspect brace wires for damage and corrosion.			X	X		
5.	Inspect float interior for damage, corrosion, etc.				X		
6.	Check bolt torque or replace hardware. (Refer to Section 16.4)			X	X		
7.	Inspect compartment covers and foam seals for condition, security, operation, and excessive wear.			X	X		
8.	Inspect pump out tubes and plugs for condition and presence.				X		
9.	Inspect bilge pump tubes for condition, security, and routing of hoses.				X		
C. Water Rudders							
1.	Inspect water rudder hinge for freedom of movement.	X*	X*	X	X		
2.	Check operation of water rudder retract system.		X*	X	X		
3.	Inspect water rudder blade and post for damage, corrosion, security, paint, rigging, etc.			X	X		
4.	Inspect water rudder bulkhead boot for cracks and wear.			X	X		
5.	Inspect control and retract cables for corrosion and wear. Inspect cable fittings for slippage.			X	X		
6.	Inspect turnbuckles, guides, and pulleys for condition, security, wear, and operation. Check for presence or cable guard pins.			X	X		
D. Electrical (Landing Gear and Probes)							
1.	Inspect pump and indicator light wiring for condition, chafing, broken or loose terminals.			X	X		
2.	Inspect solenoids & wiring for condition and security.			X	X		
3.	Inspect pressure switches & wiring for condition and security.			X	X		
4.	Inspect pump motors & wiring for condition and security			X	X		
E. Landing Gear Systems							
1.	Clean and lubricate nose gear tracks.	X*	X*	X	X		
2.	Check for wear of nose gear blocks and tracks (0.050 inches or less wear tolerance).				X		
3.	Check nose gear pivot block and fork for condition, lubrication, corrosion, and finish.	X*	X*	X	X		
4.	Inspect nose gear spring for condition. (Refer to Figure 2.1) NOTE: Replacement recommended at 2500 hours.			X	X		

		Inspection Interval				Mechanic	
		25	50	100	Annual	Left	Right
Maintenance Checks							
5.	Check nose gear spring bolt torque or replace hardware. (Refer to Section 16.4)			X	X		
6.	Check wheels and tires for condition, wear, and pressure.		X*	X	X		
7.	Lubricate nose and main wheel bearings. Grease zerk fittings.	X*	X*	X	X		
8.	Disassemble and inspect nose and main wheel bearings.				X		
9.	Inspect hydraulic pump, accumulator assembly, and Vickers valve for leaks, condition and security.			X	X		
10.	Inspect hydraulic lines, fittings, and manifolds for leaks, condition and security.				X		
11.	Check hydraulic fluid level.		X*	X	X		
12.	Check hydraulic fluid for moisture or other contaminants. Change fluid if necessary.				X		
13.	Check screen inside hydraulic fluid reservoir. Clean and inspect condition. NOTE: If floats sit for an extended period of time (i.e. floats removed over winter), clean screen and inspect condition prior to returning to service.				X		
14.	Check inline filters (3) at accumulator assembly. Clean and inspect condition. Replace if needed. NOTE: If floats sit for an extended period of time (i.e. floats removed over winter), clean inline filters and inspect condition prior to returning to service.				X		
15.	Replace spin-on filter.				X		
16.	Inspect spin-on filter bypass flag (if equipped). If popped, remove and clean or replace all filters.	X*	X*	X	X		
17.	Inspect main and nose gear actuator assemblies for condition, lubrication, cleanliness, leakage, and corrosion. NOTE: Refer to Service Letter 80 for operations from sand and gravel.			X	X		
18.	Inspect main gear drag link for condition, lubrication, and corrosion. Check attach bolts for wear.			X	X		
19.	Inspect main gear shock strut for condition, corrosion, pitting, and cleanliness. Check lower attach bolt for wear and lubrication.		X*	X	X		
20.	Service main gear shock strut (Refer to Section 2.5)				X		
21.	Inspect main gear lower attach bolt for wear and lubrication.				X		
22.	Inspect nose gear trolley for proper travel.				X		
23.	Inspect nose gear for excessive side-to-side movement in the down position.				X		
24.	Check hand pump operation. Perform emergency gear extension.				X		
25.	Inspect brake assemblies for wear, corrosion, and leakage.		X*	X	X		
26.	Inspect brake system lines and fittings for leaks, condition, and security.				X		
27.	Perform retraction test. Inspect up and down for proper engagement. (Refer to Section 2.7)				X		

		Inspection Interval				Mechanic	
		25	50	100	Annual	Left	Right
Maintenance Checks							
E. Fuselage Frame							
1.	Inspect fuselage tubing, gussets, and float attaching components for bending or weld cracking. Inspect area of front float strut and main float pylon attach.				X		
2.	Inspect fuselage tubing and pedestal mounts for cracking (refer to Service Letter 170)		X	X	X		
F. Water Pickup Probes							
1.	Perform retraction test. Check for retraction speed of approximately one second (Refer to Section 4.2)			X	X		
2.	Inspect probe up position (Refer to Figure 4.2B)			X	X		
3.	Inspect probe down position for proper seating and alignment of tubes (Refer to Figure 4.2C)			X	X		
4.	Inspect probe jack cylinder for leaks, condition, and security.			X	X		
5.	Inspect probe for damage and cracking at welds.			X	X		
6.	Inspect area around probe opening for damage.	X*	X*	X	X		
G. Auxiliary Finlets (Without Support Fittings)							
1.	Clean and inspect finlet and support struts for damage, cracks, security, and missing gaskets.		X*	X	X		
2.	Remove finlets, support struts, and rectangular access cover. Inspect finlets, struts, and weldments for cracks. Inspect horizontal stabilizer spars for cracks. (Refer to Section 10.2 and Service Letter 253)			X	X		
3.	Check finlet attach bolt torque or replace hardware. (Refer to Section 16.4)			X	X		
H. Auxiliary Finlets (With Support Fittings)							
1.	Clean and inspect finlet and support struts for damage, security, cracks, and missing gaskets.		X*	X*	X		
2.	Remove oval and leading edge access covers adjacent to finlets. With finlets in-place inspect finlets, struts, weldments, and support fittings for cracks. Inspect horizontal stabilizer spars for cracks. (Refer to Service Letter 253)			X	X		
3.	Check finlet attach bolt torque, support fitting to bolt torque, or replace hardware. (Refer to Section 16.4, 16.5, 16.6) NOTE: Remove and inspect finlets and front support fittings every 1500 hours time in service.				X		

16.2 OVERWEIGHT / HARD LANDING INSPECTION CHECKLIST

The landing gear is designed for landing loads of approximately +2.5g. An excessive decent rate, exceeding 12100 lb, soft or irregular surface, severe braking, or severe side load may result in damage. If an overweight / hard landing is reported or suspected, conduct the following inspections.

		Mechanic	
Overweight / Hard Landing Checks		Left	Right
A. Nose Landing Gear			
1.	Inspect nose wheels for damage, wear, and loose hardware to include axle. Loose or damaged hardware will require further inspection for deformation and hole elongation.		
2.	Inspect nose tires for wear, pressure, and condition. (Refer to Section 2.2 for pressure)		
3.	Inspect for damage to nose wheel bearings and seals.		
4.	Inspect nose spring for cracks, delamination, and loose hardware. (Refer to Section 2.2)		
5.	Inspect pivot blocks and nose forks for bending, cracks, and loose hardware. Loose or damaged hardware will require further inspection for deformation and hole elongation.		
6.	Inspect nose gear trolley for evidence of damage near attach points. Inspect attached linkages including the over-center down lock mechanism, trolley blocks, and trolley axles. If damage is found, replace damaged components and accomplish gear swing; look for binding and replace additional components as needed.		
7.	Inspect nose gear ram assembly and rod end for damage and proper functionality. Perform retraction/extension test. (Refer to Section 2.7)		
B. Main Landing Gear			
1.	Inspect main wheels for wear, damage, and loose attaching hardware to include axle. Loose or damaged hardware will require further inspection for deformation and hole elongation.		
2.	Inspect main tires for wear, pressure, and condition. (Refer to Section 2.4 for pressure)		
3.	Inspect for damage to main wheel bearings and seals.		
4.	Inspect drag link, tube, and axle assembly for damage, attach point failure, loose and sheared hardware.		
5.	Inspect main gear trunnion attachment for damage and loose hardware. Inspect surrounding bulkhead and attach points for damage.		
6.	Inspect main gear shock strut attach points for wear, cracking, and hardware failure.		
7.	Inspect brake linings and calipers for evidence of over temperature, wear, and leaks.		
C. Main Landing Gear Retraction			
1.	Inspect main gear attachment points for damage, loose and sheared hardware. Loose or damaged hardware will require further inspection for deformation and hole elongation.		
2.	Inspect carriage for evidence of damage and proper functionality. Perform retraction test. Inspect up and down for proper engagement. (Refer to Section 2.7)		
3.	Inspect slide tube attach points for damage and loose or sheared hardware to include slide tube concentricity.		
D. Float Hulls			
1.	Inspect float exterior for evidence of wrinkled metal, smoking rivets, and popped fasteners.		
2.	Inspect keel for any evidence of contact with runway.		
3.	Inspect float compartment bulkheads for deformation, buckling, and popped fasteners.		
4.	If equipped, inspect foam tank tanks and attach points for cracks and damage.		
5.	Inspect float top deck, strut attach points and surrounding area for damage. Inspect for evidence wrinkled metal, smoking rivets, and popped fasteners.		

		Mechanic	
Overweight / Hard Landing Checks		Left	Right
E.	Struts & Spreader Bars		
1.	Inspect struts, spreader bars, and rigging for damage and loose attaching hardware. Loose or damaged hardware will require further inspection for deformation and hole elongation.		
2.	Inspect strut and spreader bar fittings for cracks and deformation at attachments.		
3.	Inspect float-to-airframe attach points and surrounding areas at fuselage for bending, cracking, or distortion.		
4.	Inspect strut attach fittings within float, bulkheads and surrounding areas for damage, cracks, and deformation.		
5.	Inspect forward and aft kicker strut attach points for distortion and loose or damaged hardware. Loose or damaged hardware will require further inspection for deformation and hole elongation.		

16.3 GEAR UP LANDING INSPECTION CHECKLIST

In the event of a gear up landing conduct the following inspections.

		Mechanic	
Gear Up Landing Checks		Left	Right
A. Main Gear Retraction			
1.	Inspect main gear attachment points for damage, loose and/or sheared hardware. Loose or damaged hardware will require further inspection for deformation and hole elongation.		
2.	Inspect carriage for evidence of damage and proper functionality. Perform retraction test. (Refer to Section 2.7) Inspect up and down for proper engagement.		
3.	Inspect slide tube attach points for damage and loose/sheared hardware to include slide tube concentricity.		
B. Float Hulls			
1.	Inspect float exterior for evidence of wrinkled metal, smoking rivets, and popped fasteners		
2.	Inspect keel for damage due to contact with runway beyond the sacrificial wear strip.		
3.	Inspect float compartment bulkheads for deformation, buckling, and popped fasteners.		
4.	If equipped, inspect foam system tanks and attach points for cracks and damage.		
5.	Inspect float top deck, strut attach points and surrounding area for damage. Inspect for evidence wrinkled metal, smoking rivets, and popped fasteners		
C. Scoop System			
1.	Inspect probe opening, scoop probe, pivot point, and hardware for damage.		
2.	Perform scoop extension and retraction check.		
D. Struts & Spreader Bars			
1.	Inspect struts, spreader bars, and rigging for damage and loose attaching hardware. Loose or damaged hardware will require further inspection for deformation and hole elongation.		
2.	Inspect strut and spreader bar fittings for cracks and deformation at attachments.		
3.	Inspect float-to-airframe attach points and surrounding areas at fuselage for bending, cracking, or distortion. If damage is observed complete engine and engine mount checks below.		
4.	Inspect strut attach fittings within float, bulkheads, and surrounding areas for damage, cracks, and deformation.		
5.	Inspect forward and aft kicker strut attach points for distortion and loose or damaged hardware. Loose or damaged hardware will require further inspection for deformation and hole elongation.		
F. Engine and Engine Mount			
1.	If damage is discovered at float-to-airframe attach points (see above), inspect engine and engine mount.		

16.4 FLOAT HARDWARE RETORQUE AND REPLACEMENT CHECKLIST

The following hardware has recommended or required torque checks and/or replacement intervals. See next page for checklist.

NOTES:

1. Fastener length may vary due to design changes in adjacent parts. The recommend replacement intervals still apply; replace with appropriate length hardware.
2. Recommended **TORQUE CHECK** of all items below: **100 hrs +/- 25 hrs** (unless otherwise noted)
3. Recommended **REPLACEMENT** of all items below: **750 hrs +/- 250 hrs** (unless otherwise noted)
4. Inspection signoff is optional
5. Torque values shown are for clean non-lubricated parts. Threads to be free of dust, metal filings, etc.
6. Tef-Gel is recommended to be applied to the bolt shank. Reduce torque values by 20% if Tef-Gel is coating the bolt threads.

WHERE SPECIFICALLY NOTED:

7. May have 11/16" nut
8. Use Loctite 242 or equivalent medium strength on bolt threads.
9. Retorque at annual inspection. Bolt replacement recommended at every 1500-hour inspection.
10. Replacement of nut required at every 1500-hour inspection.

Item	Bolt Location	Bolt Part Number	Bolt Qty Per Aircraft	Bolt Diameter	Wrench Size	Bolt Torque See Note 5	80% Bolt Torque (Installed with Tef-Gel) See Note 6	Washer Part Number	Washer Qty Per Aircraft	Nuts	Inspection Signoff
1	Fwd strut- Landing gear stub to upper strut fitting	AN10-65A	2	5/8"	15/16"	55 ft-lbs	44 ft-lbs	NAS1149F1063P	4	MS21044N10	
2	Fwd strut- Upper strut fitting to strut assembly	AN10-32A	2	5/8"	15/16"	55 ft-lbs	44 ft-lbs	NAS1149F1063P	4	MS21044N10	
3	Fwd strut- Upper strut fitting through bolts	AN5-36A AN5-33A	4 4	5/16" 5/16"	1/2" 1/2"	6 ft-lbs 6 ft-lbs	5 ft-lbs 5 ft-lbs	NAS1149F0563P NAS1149F0532P	8 8	MS21044N5 MS21044N5	
4	Fwd strut- Lower strut fitting through bolts	AN5-33A AN25-52A	6 2	5/16" 5/16"	1/2" 1/2" (slotted head)	6 ft-lbs 6 ft-lbs	5 ft-lbs 5 ft-lbs	NAS1149F0532P NAS1149F0532P	12 2	MS21044N5	
5	Fwd strut- Lower strut fitting to internal float fitting	AN10-30A	2	5/8"	15/16"	55 ft-lbs	44 ft-lbs	NAS1149F1063P	4	MS21044N10	
6	Fwd spreader bar- Internal float fitting to spreader bar fitting	AN10-30A	2	5/8"	15/16"	55 ft-lbs	44 ft-lbs	NAS1149F1063P	4	MS21044N10	
7	Fwd spreader bar- Spreader bar fitting/tow lug through bolts	AN5-40A	8	5/16"	1/2"	6 ft-lbs	5 ft-lbs	NAS1149F0563P	16	MS21044N5	
8	Center bolt flywires to fwd kicker struts	AN10-37A	1	5/8"	15/16"	55 ft-lbs	44 ft-lbs	NAS1149F1063P	2	MS21044N10	
9	Fwd kicker struts to upper kicker strut mount/saddle	AN7-26A AN7-32A	2 2	7/16" 7/16"	5/8" 5/8" (Note 7) 5/8" (Note 7)	41 ft-lbs 41 ft-lbs	33 ft-lbs 33 ft-lbs	NAS1149F0763P NAS1149F0763P	4 6	MS21044N7 MS21044N7	
10	Main pylon- Upper rear fuselage fitting to top of pylon	AN12-36A	2	3/4"	1 1/16"	110 ft-lbs	88 ft-lbs	NAS1149F1232P	2	MS21044N12	
11	Main pylon- Fwd bolt through topdeck	AN10-25A	2	5/8"	15/16"	105 ft-lbs	84 ft-lbs	NAS1149F1063P	2	13A02458-005	
12	Main pylon- Aft bolt through topdeck (S.L. 182)	MS20008-15	2	1/2"	3/8" Allen Head 5/8" 12 pt nut	75 ft-lbs	60 ft-lbs	MS20002C8 MS20002-8	2 2	NAS1805-8	
13	Main pylon- Inboard pylon to internal float fitting	AN8-32A	2	1/2"	3/4"	30 ft-lbs	24 ft-lbs	NAS1149F0863P	4	MS21044N8	

SERVICE MANUAL & ICA
10000 AMPHIBIAN FLOATS ON AIR TRACTOR AT-802A

Item	Bolt Location	Bolt Part Number	Bolt Qty Per Aircraft	Bolt Diameter	Wrench Size	Bolt Torque See Note 5	80% Bolt Torque (Installed with Tef-Gel) See Note 6	Washer Part Number	Washer Qty Per Aircraft	Nuts	Inspection Signoff
14	Rear spreader bar- Internal float fitting to aft spreader bar fitting	AN10-31A	2	5/8"	15/16"	55 ft-lbs	44 ft-lbs	NAS1149F1063P	4	MS21044N10	
15	Rear spreader bar- Spreader bar fitting through bolts	AN6-34A	8	3/8"	9/16"	8 ft-lbs	6 ft-lbs	NAS1149D0616J	16	MS21044N6	
16	Rear spreader bar- Center spreader bar fitting to rear kicker struts	NAS6209-31	2	9/16"	7/8"	45 ft-lbs	36 ft-lbs	NAS1149F0932P	2	MS21083N9	
17	Upper rear fuselage fitting to rear kicker struts	NAS6209-26	2	9/16"	7/8"	45 ft-lbs	36 ft-lbs	NAS1149F0932P	2	MS21083N9	
18	Nose gear spring- Upper spring bolts to trolley	AN8-32A AN7-30A	4 4	1/2" 7/16"	1/2" 5/8" (Note 6)	57 ft-lbs 41 ft-lbs	46 ft-lbs 33 ft-lbs	NAS1149F0863P NAS1149F0832P NAS1149F0763P NAS1149F0732P	2 2 2 2	MS21044N8 MS21044N7	
19	Nose gear spring- Lower spring bolts to pivot block	AN7-24A	8	7/16"	5/8" (Note 6)	41 ft-lbs	33 ft-lbs	NAS1149F0732P NAS1149F0763P	4 4	MS21044N7	
20	Nose gear pivot block to nose fork leg	AN7-43A or MS20007-62	4	7/16"	5/8" (Note 6)	41 ft-lbs	33 ft-lbs	NAS1149F0732P NAS1149F0763P	4 4	MS21044N7	
21	Finlet attach bolts without support fittings	NAS624-8 or NAS6604-8	16	1/4"	5/16"	5 ft-lbs (Note 8)	N/A	MS20002C4	16	N/A	
22	Finlet attach bolts with support fittings	NAS624-10 (Note 9)	16	1/4"	5/16"	5 ft-lbs	N/A	MS20002C4 NAS620-416	16	MS21042-4 (Note 9)	
22	Inner finlet support fitting	AN173-7A	6	3/16"	3/8"	2 ft-lbs	1.5 ft-lbs	NAS1149F0363P NAS1149F0332P	1 2	MS21044N3 (Note 10)	
23	Outer finlet support fitting	AN173-6A	6	3/16"	3/8"	2 ft-lbs	1.5 ft-lbs	NAS1149F0363P NAS1149F0332P	1 1	MS21044N3 (Note 10)	

16.5 FINLET & ATTACHMENT

Annual inspection of finlet and attachment:

To inspect finlet & attachment:

1. Remove 24 screws securing left and right oval inspection covers to stabilizer, remove oval inspection covers.
2. Remove 8 screws securing left and right leading edge inspection covers to stabilizer and remove cover by sliding forward.
3. Inspect front finlet support fitting (P/N 100966) in place from the oval access provision. Place emphasis on radius at end pads, corners of vertical web, and cracking from attach bolts. Inspect for presence and condition of upper and lower fitting to spar shims (P/N 1001909).
4. Inspect aft face of front spar from the oval access provision. Place emphasis on upper and lower flange radius near finlet attachments and rivets through the upper and lower spar flanges.
5. Inspect front face of aft spar from the oval access provision. Place emphasis on fitting rivets and spar flange radius near the finlet attachments.
6. Inspect front face of the front spar from the leading edge access provision. Place emphasis on fitting bolts, spar web rivets, and spar flange radius near finlet attachments.
7. Inspect the aft face of the rear spar. Place emphasis on upper and lower flange radius near finlet attachments and support strut fitting (if equipped).
8. Inspect rear finlet support fitting (P/N 100967). Place emphasis on radius at end pads, corners of vertical web, and cracking from rivet or bolt locations. Inspect for presence and condition of upper and lower spar to fitting shims (P/N 1001908).
9. If equipped, inspect finlet support struts and upper and lower fittings for condition and cracks.
10. Inspect front and rear finlet weldments in place for condition and cracks.
11. Inspect finlet skin for condition and cracks. Place emphasis on areas near finlet attachments and support strut fitting (if equipped).
12. Inspect stabilizer skins, skin patch, oval ring doubler, and leading edge ring doubler for condition and cracks.
13. Check torque of support fitting to spar bolts. If observed torque is less than 16 in-lb, inspect per Section 16.6.
14. Check torque of finlet to stabilizer bolts. If observed torque is less than 50 in-lb; inspect per Section 16.6.

Rejection criteria:

1. Any spar, fitting, or component found to have a crack, no matter how small, is not airworthy. It must be replaced with an airworthy part before further flight.
2. Any spar, fitting or component found to be corroded is not airworthy. It must be replaced with an airworthy part before further flight.

Reinstallation:

1. Install leading edge inspection cover; slide covers aft and install 8 screws.
2. Install left and right oval inspection covers with 24 screws.

16.6 HORIZONTAL STABILIZER SPAR & FINLET SUPPORT FITTINGS

1500-hour inspection of front horizontal stabilizer spar and P/N 1001966 finlet support fittings:

Remove front finlet support fittings as follows:

1. Remove 24 screws securing left and right oval inspection covers to stabilizer, remove oval inspection covers.
2. If equipped, mark finlet support strut location (left or right) and remove 10 bolts securing strut fittings to finlet and stabilizer. Remove finlet support strut / fitting assembly in whole.
3. Mark finlets (i.e left upper). Remove 16 bolts securing finlets to stabilizer. Discard 16 nuts (P/N MS21042-4).
4. Remove 8 screws securing left and right leading edge inspection covers to stabilizer and remove cover by sliding forward.
5. Mark forward finlet support fittings for position (i.e left, outboard) and orientation (i.e. top).
6. Remove 12 bolts securing finlet support fittings to stabilizer spar. Discard 12 nuts (P/N MS21044N3).
7. Remove finlet support fittings from stabilizer and remove attach bolts from spar.

Inspect removed fittings (P/N 100966) as follows:

1. Visually inspect fitting under magnification of a least 10X. Place emphasis on bolt holes, radius at end pads, and corners of vertical web.

Rejection criteria:

1. Any fitting found to have a crack, no matter how small, is not airworthy. It must be replaced with an airworthy part before further flight.
2. Any fitting found to be corroded or to have elongated bolt holes is not airworthy. It must be replaced with an airworthy part before further flight.

Inspect front horizontal stabilizer spar as follows:

1. Visually inspect aft face of the spar from the oval access provision. Place emphasis on upper and lower flange radius near finlet attach holes, shaved rivets (4 places in spar web), rivets through upper and lower spar flanges, and fitting bolt holes.
2. Visually inspect of the front face of the spar from the leading edge access provision. Place emphasis on upper and lower flange radius near finlet attach holes, shaved rivets (4 places in spar web), and fitting bolt holes.

Rejection criteria:

1. Any spar found to have a crack, no matter how small, is not airworthy. It must be replaced with an airworthy part before further flight.
2. Any spar found to be corroded or to have elongated bolt holes is not airworthy. It must be replaced with an airworthy part before further flight.

Reinstallation:

1. Install finlet support fittings (P/N 100966) in original location and orientation. Observe that upper and lower shims are present and fit is snug between spar flanges. Install fittings using 12 new nuts (P/N MS21044N3). Replacement of the AN173 fitting attach bolts is recommended. Torque 20-25 in-lb.
2. Install leading edge inspection cover. Slide covers aft and install 8 screws.
3. Install finlets in original location. Install finlets using 16 new nuts (P/N MS21042-4). Observe that a MS20002C4 washer is under the bolt head and NAS620-416 washer is under the nut. Replacement of the NAS624 finlet attach bolts is recommended. Torque 50-70 in-lb.
4. If equipped, install support strut / fitting assembly to finlet and stabilizer in original location with 10 bolts.
5. Install left and right oval inspection covers with 24 screws.

CHAPTER 17 WEIGHT AND BALANCE

CONTENTS

17.1 WEIGHING PROCEDURES FOR THE AT-802A FIRE BOSS AMPHIBIAN	118
--	-----

CHAPTER 17 - WEIGHT AND BALANCE

17.1 WEIGHING PROCEDURES FOR THE AT-802A FIRE BOSS AMPHIBIAN

Level aircraft per manufacturer's instructions.

Place scales under the right and left nose and main gear wheels.

Blocking will be required to level airplane.

Drop plumb bob from wing leading edge on either side of the plane to the floor and mark. This is the datum-line, station 0.0.

Draw another line between the nose wheel centers and a 3rd line between the main wheel centers.

Measure the distance from 0.0 to the nose wheel line. This is X.

Measure the distance from 0.0 to the main wheel line. This is Y.

Use this table for the calculations:

Scale Reading	Distance from 0.0	Weight x Arm			
	Weight	x	Arm	=	Moment
Left Front	+	-	X	-	
Right Front	+	-	X	-	
Left Rear	+	+	Y	+	
Right Rear	+	+	Y	+	

Totals

NOTE: Zero out or deduct tare weights at the Y arm.