



SERVICE LETTER NUMBER 56			
TITLE: MAIN LANDING GEAR SHOCK STRUT REPLACEMENT – 3000A, 3450A			
BY: MAB	AIRCRAFT MAKE/MODEL(S):	FLOAT MODEL(S):	NOTE(S):
APP: SDW	SEE COMPLIANCE SECTION	3000A	COMPLIANCE MANDATORY
DATE: 4/15/2019	OF THIS SERVICE LETTER	3450A	
REV: B.1			S/L P/N 1002434

FAA APPROVAL HAS BEEN OBTAINED FOR TECHNICAL DATA IN THIS PUBLICATION THAT AFFECTS STC OR TSO DESIGN COMPLIANCE

EFFECTIVITY:

3000A S/N's: 30094A & DN
3450A S/N's: 34084A & DN

COMPLIANCE:

Service Kit #39 (p/n 1002521) applies to float models **3000A** and **3450A** on the following aircraft:

- CESSNA 180 (THROUGH K MODEL)
- CESSNA 185 –E, A185E, A185F
- CESSNA 182 P, Q, R, S, T
- CESSNA 206H, T206H
- CESSNA T/U206 (THROUGH G MODEL)
- MAULE M6-235
- MAULE M7-235, M7-260, M7-420, MT7-235, MT7-260, MT7-420
- MAULE MX7-235

Install Service Kit #39 (p/n 1002521) within 2 years or at next annual inspection or major disassembly of the shock strut assembly.

BACKGROUND:

The cotter pins in the retaining pin at the top of the shock strut may have been damaged and come out. This will result in the retaining pin working its way out and the shock strut coming apart.

This may be a result of taxiing on rough taxiways, landing on rough landing strips, hard landings, or corrosion.

COMPLIANCE METHOD:

For 3000A or 3450A Floats – Install Service Kit #39 (p/n 1002521)

APPROX. SHOP HOURS:

Approximately 4 hours

WARRANTY INFORMATION:

Parts only for 18 months past the original issuance of this service letter.

TECHNICAL DATA:

1002521 BILL OF MATERIALS

<u>ITEM</u>	<u>QUANTITY</u>	<u>PART NO.</u>	<u>DESCRIPTION</u>
1	2	30A04000-120	ASS'Y – END SHOCK STRUT LOWER
2	2	30A04476-004	RETAINING PIN
3	2	30A04459-002	SLEEVE
4	2	MS24665-151	COTTER PIN

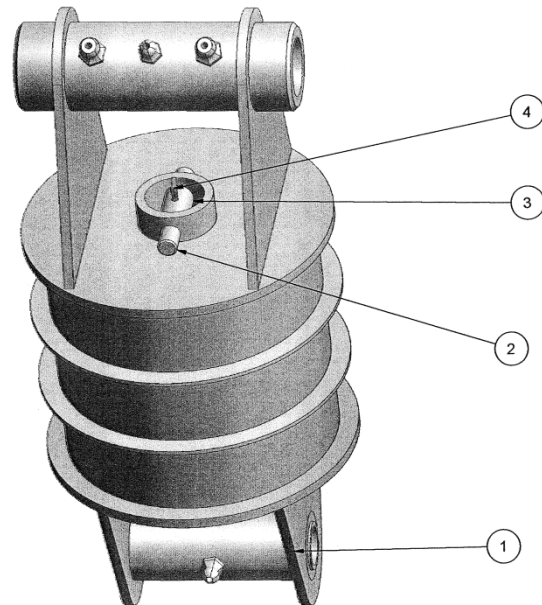

Obsolete Superseded by Service Letter 67

1002521 INSTALLATION INSTRUCTIONS:

REMOVAL:

1. Remove access covers over main gear tunnel.
2. Remove gear indicator arm.
3. Remove aft track spreader plate, ref figure 6-7. (Ref. Service Manual)
4. Aircraft fuel tanks to be full, and then apply enough weight to floats to release pressure on retaining pins in top of shock struts. Protect and evenly distribute weight on float so it will not be damaged. Examples: lead shot, sandbags, containers filled with water. This can also be accomplished with water. This can also be accomplished with several people sitting on the float. Weight varies with each installation.
5. Remove cotter pins and remove retaining pins from shock strut.
6. Remove weight from aft end of floats.
7. Jack and block aircraft per Section 4 and Figure 6-3 of your Service Manual.

Note: Jack close to rear step bulkhead and spread load over 1.5' – 2' on keel or you will damage the keel. Raise float to 12" from keel to ground.

8. Remove tires and brakes.
9. Use hand pump and raise gear until shock struts come apart.
10. Remove bolt that attaches shock strut to gear drag link.
11. With shock strut out remove rubber donuts, spacers, bushing and grease zerk.

ASSEMBLY:

12. Assemble item (1) p/n 30A04000-120 lower end shock strut, existing rubber donuts, spacers, bushing and grease zerk.
13. Install lower end shock strut assembly in gear drag tube and bolt together.
14. Use hand pump to lower gear to the down position, line up holes in item (2) p/n 30A04476 retaining pin and item (3) p/n 30A04459-002 sleeve.
15. Reinstall tire and brake.
16. Lower aircraft to ground; apply enough weight to install item (2) p/n 30A04476-004 retaining pin and item (3) p/n 30A04459-002 sleeve.
17. Line up cotter pin holes and install item (4) p/n MS24665-151 cotter pin.
18. Install track spreader plate.
19. Install gear indicator arm in shock strut.
20. Install access cover on float.
21. With installation complete, Do Complete Gear Cycle. Raise Aircraft off ground.
See Note in Step 7.

NOTE: Periodic checking for corrosion is necessary in this area of the float, and it depends on corrosion conditions in your area.

NOTES:

- 1) Upon completion of inspection, enter information in float logbook for completion of Wipaire Service Letter 56.
- 2) Once service letter is accomplished, please visit www.wipaire.com and update your aircraft service letter/kit record using the link found on the Customer Support dropdown menu under "Update Service Letter & Kit Compliance Status".

END

Obsolete Superseded by Service Letter 67