

SERVICE LETTER NUMBER 138			
10000 and 13000 Nose Gear End Cap Cracks			
BY: MAB	AIRCRAFT	FLOAT MODEL(S):	NOTE(S):
APP: SDW	MAKE/MODEL(S):	10000A	MANDATORY
DATE: 10/22/2019	FIREBOSS 802/802A	13000A	COMPLIANCE
REV: D	VIKING DHC-6		S.L. P/N 1003610

FAA APPROVAL HAS BEEN OBTAINED FOR TECHNICAL DATA IN THIS PUBLICATION THAT AFFECTS STC OR TSO DESIGN COMPLIANCE.

EFFECTIVITY:

All Model 10000A Amphibious Floats up to and including Serial No. 10118A

All Model 13000A Amphibious Floats up to and including Serial No. 13178A

COMPLIANCE:

Within the next 25 hours of operation, inspect the Nose Gear Box End Cap, part # 13A07201-003 for cracks.

BACKGROUND:

Several Nose Gear Box End Caps, part #13A07201-003 have been found to have cracks propagating from around the Cylinder Mounting Flange bolts (4). If these cracks go undetected there is a possibility that the End Cap, Part #13A07201-003 can break and let the actuator cylinder move to a selected gear position without actuating the gear properly. This condition could potentially lead to a gear indication suggesting that a selected nose gear position has been reached, when it has not.

COMPLIANCE METHOD:

A close visual inspection must be accomplished within the next 25 hours of operation, and every 50 hours thereafter. The cracks will be best visible by looking at the forward face of the End Cap, Part #13A07201-003 through the forward open end of the Nose Gear Box. It appears that the cracks start just above the top mounting bolt and just below the bottom mounting bolt as shown in Figure 1. If cracks are found, the End Cap Part #13A07201-003 must be replaced with the new revision, End Cap, Part #13A07201-003, Revision E, dated October 2nd, 2012 or later. In addition, replace the (4) AN3-20A mounting bolts with (4) AN3-21A bolts. After inspection and/or replacement, re-adjust the gear “down” over-center lock so that it hits the end of the lock-up track and has little to no preload pressure, since the preload pressure would cause extra stress at the Cylinder Mounting Flange and the End Cap.

Replacement of the older revision parts with revision E parts will eliminate the requirement for 50 hour interval inspections, but this inspection should still be accomplished at 100 hour intervals thereafter. Revision E parts can be identified by (4) added slots as shown in Figure 2.

APPROX. SHOP HOURS:

Inspection-1 hour

Replacement of End Caps, 5-8 hrs. per float

WARRANTY INFORMATION:

No longer applicable. Warranty has expired.

TECHNICAL DATA:

Drawing # 13A07201-003 (Revision E or later)

NOTES: Figure 1 shows the part that is cracked, and figure 2 shows its location on the nose box assembly. This is the forward side of the part which can be seen looking into the open (front) end of the nose gear box. No disassembly should be required to examine this area. The area should be thoroughly cleaned before inspecting. Use good lighting. If in doubt, dye penetrant inspection can also be accomplished.



If evidence of cracking is found in Nose Box End Cap either by visual or dye penetrant inspection per figure 1, the following instructions will be accomplished to replace damaged Nose Box End Cap:

ITEMS PROVIDED IN SERVICE KIT 1003610-01

QTY	PART NUMBER	DESCRIPTION
1	13A07201-003 (Rev E or later)	END CAP - NOSE BOX
4	AN3-21A	BOLT
A/R	MS20426AD5 or NAS1097AD6	FLUSH HEAD RIVETS
A/R	MS20470AD5 or AD6	UNIVERSAL HEAD RIVETS
A/R	PR-1428-B-2-654	PR2 SEALANT

1. Position aircraft safe for maintenance.
2. Support aircraft on jacks so that there is no weight on float landing gear.
3. Remove forward float deck access cover to access Nose box end cap.
4. Relieve residual Hydraulic pressure by cracking Hyd. Fitting on Nose gear actuator and disconnect.
5. Cap and plug fittings.
6. Remove Nose Gear Box Assembly per Maintenance Manual. Save hardware for reinstallation.
7. Remove bolts (4) and washers (4) from Hyd. actuator cylinder and separate from Nose Box Assembly.

CAUTION: Hydraulic fluid will drain from Cylinder.

8. Disconnect and remove Hydraulic Ram from Nose Gear Rod End by rotating counterclockwise. Count threads showing on Nose Gear Rod End for reinstallation.
9. Remove Bolts (4), washer (4), and Nuts (4) from Cylinder Flange Assembly and save for installation.
10. Remove Cylinder Flange Assembly, Flange Plate, and Flange Cylinder nose gear ram Spacer.
11. Drill out all rivets securing Nose box End Cap and remove.

NOTE: Proper Surface Cleaning and Preparation must be accomplished prior to installation of Replacement Nose Box End Cap.

12. Install End Cap and back drill, using #30 drill bit, for initial fitment.
13. Remove Nose End Cap and remove any burrs left from back drilling.
14. Apply a thin coat of PR2 Sealant to End Cap surface that will contact the Nose Box Assembly.
15. Reinstall Nose Cap and Secure top and bottom of nose box with MS20470AD5 or AD6 rivets and sides of nose box with MS20426AD5 or NAS1097AD6.
16. Apply a thin coat of PR2 Sealant to Cylinder Flange Assembly, Flange Plate, and Flange Cylinder nose gear ram Spacer mating surfaces and reinstall with replacement AN3-21A Bolts (4), washers (4), and Nuts (4).

17. Torque bolts to spec per Maintenance Manual.
18. Install Hydraulic ram, noting amount of threads from step 8 are showing on Nose Gear Rod End.
19. Install Hydraulic Actuator Cylinder, taking care not to pinch packings.
20. Secure with hardware from Step 6.
21. Torque bolts to spec per Maintenance Manual.
22. Reinstall Nose Gear Box Assembly per Maintenance Manual
23. Apply bead of PR2 Sealant around Nose gear assembly for water tight seal.
24. Connect Hydraulic line to Hyd. Cylinder.
25. Re-adjust the gear “down” over-center lock so that it hits the end of the lock-up track and has little to no preload pressure per Maintenance Manual.
26. Bleed Hydraulic System per Maintenance Manual.
27. Final Gear swing and travel check must be accomplished before jacks are removed.
28. Remove aircraft from jacks.
29. Return aircraft to service.

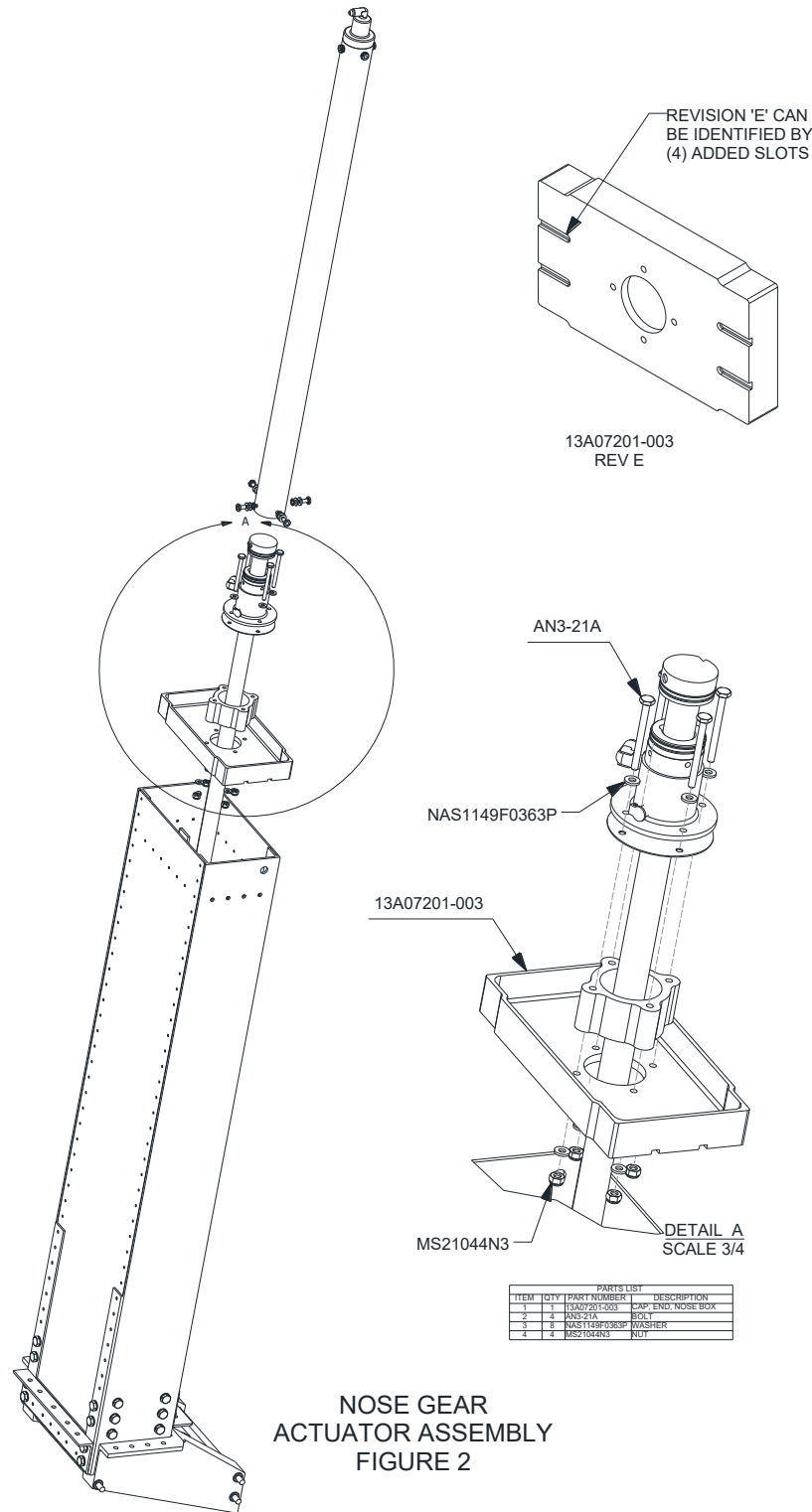

###