



WIPLINE FLOATS • SKIS • MODIFICATIONS • AIRCRAFT SALES
AVIONICS • INTERIOR • MAINTENANCE • PAINT REFINISHING

SERVICE LETTER 112

OPTIONAL HYDRAULIC POWER PACK TIMER RELAY INSTALLATION

Aircraft Makes/Model(s):	Float Model(s):	Compliance: Recommended	By: MAB
SA00637CH, SA00674CH, SA00713CH, SA0073CH, SA00804CH, SA00900CH, SA00910CH, SA001156CH, SA01185CH, SA01320CH, SA01272CH	2100, 2350, 3000, AND 3450 AMPHIBIAN FLOATS	Part Number: 1005052	Approved: SDW
		Date: 5/21/2019	Revision: D

FAA approval has been obtained for technical data in this publication that affects STC or TSO design compliance

EFFECTIVITY:

This service letter applies to all aircraft modified by STCs SA00637CH, SA00674CH, SA00713CH, SA0073CH, SA00804CH, SA00900CH, SA00910CH, SA001156CH, SA01185CH, SA01320CH, SA01272CH.

Note: Float installations from roughly 2012 and newer incorporate changes from this service letter. If the hydraulic pump cycles on for about 2 seconds every time the master switch is turned on, compliance with this service letter is not necessary.

- Aircraft with 12V power systems, use kit 1005052-01.
- Aircraft with 24V power systems, use kit 1005052-02.

COMPLIANCE:

Compliance with this service letter is optional, but recommended.

BACKGROUND:

Wipaire Engineering received several reports of hydraulic system malfunctions. Pressure lock of the system was determined to be the cause and adding this timer relay will enable the system to function as designed. This is a recommended product enhancement by Wipaire Engineering to improve the function of the hydraulic system.

COMPLIANCE METHOD:

Install parts in accordance with instructions in this service letter.

APPROX. SHOP HOURS:

This Service Letter will take approximately 1-3 labor hours, based on aircraft configuration.

WARRANTY INFORMATION:

This service letter includes warranty parts. Labor is not covered under warranty.

1700 Henry Ave - Fleming Field (KSGS), South St. Paul, MN 55075

Phone: 651.451.1205 | Fax: 651.457.7858

www.wipaire.com

TECHNICAL DATA:

Copies of this service letter, float service manual, modification drawing, and float parts manual are available on the website www.wipaire.com.

For basic Float model maintenance information, see Wipaire applicable Service Manual on website www.wipaire.com.

For basic Float model parts information, see applicable Wipaire Parts Manual on website www.wipaire.com.

INSTALLATION PROCEDURE

1. Although it is possible to complete work with the hydraulic pump installed in the aircraft, it is recommended that the hydraulic pump is removed from the aircraft for easier access.
2. Remove backshell from three-wire round plug on pump side of connection.
 - a. Cut back heat shrink 1" from plug end.
 - b. Remove pin 1 from round connector.
 - i. Cut off pin and strip insulation back on removed wire and one of the wires coming from terminals 1 and 4 from one of the timer delay relays. (It doesn't matter which relay.)
 - ii. Using pin 66099-4 crimp both wires together in the pin and reinstall into pin 1 location in plug.
 - c. Remove pin 2 from round connector.
 - i. Cut off pin and strip insulation back on removed wire and the wire coming from terminals 1 and 4 from the other timer delay relay.
 - ii. Using pin 66099-4 crimp both wires together in the pin and reinstall into pin 2 location in plug.
 - d. Reinstall backshell onto three-wire round plug
3. Disconnect two-wire molex plug on down pressure switch. (Down pressure switch is labeled "DN" in the pump casting at the hydraulic fittings.)
 - a. Remove pin 1 from molex housing. (Pin 1 is the pin in the pointed end of plug.)
 - i. Cut off pin and strip insulation back on this wire and the wire coming from #3 terminals from the timer delay relay assembly.
 - ii. Using 94F1671 crimp both wires together in the pin and reinstall into molex housing pin 1.
 - b. Reconnect down pressure switch
4. Connect the wire from #2 terminals from the timer delay relay assembly to ground using R-3 terminal ring or equivalent.
5. Mount the timer delay relay assembly to an available space on the hydraulic pump mount. Reference drawing for suggested installation location.
6. If removed, reinstall hydraulic pump in aircraft.
 - a. Bleed all air from hydraulic system.
 - i. Removal of hydraulic accumulators is optional if previously installed.
7. Put aircraft on stands and perform a gear retraction/extension test to make sure the system is functioning correctly.
 - a. To test timer relay:
 - i. With gear and selector in down position, turn master switch on. Pump should run for two seconds. Put gear in up position. Let gear retract all the way up and stop then turn master switch off.
 - ii. With the gear and selector in up position, turn master switch on. Pump should run for two seconds. Put gear in down position and let gear extend down. Turn master switch off.
 - b. Remove aircraft from stands.
8. Complete logbook entry showing compliance with Service Letter 112.
9. Once service letter is accomplished, please visit www.wipaire.com and update your aircraft service letter/kit record using the link found on the Customer Support dropdown menu under "Update Service Letter & Kit Compliance Status."

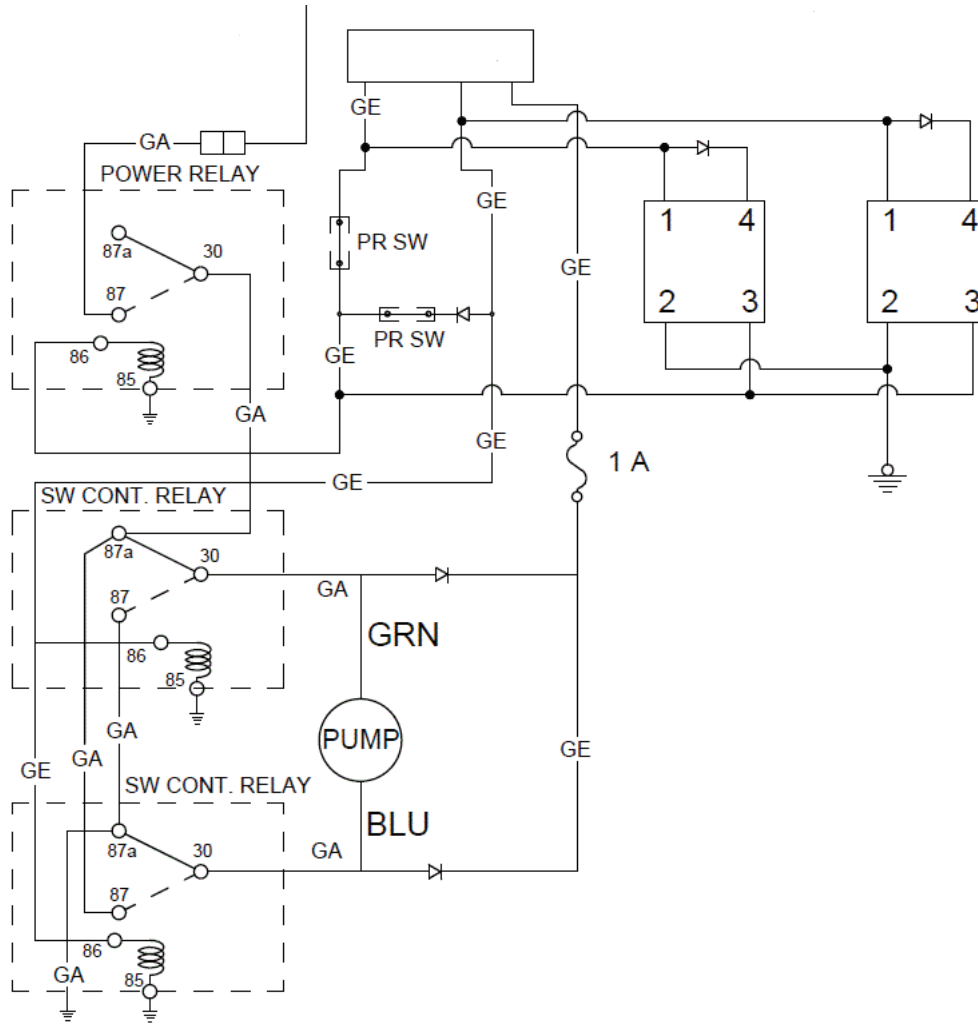

ELECTRICAL SCHEMATIC

PUMP WIRING SCHEMATIC

(RELAYS SHOWN IN RELAXED CONDITION)

1. GE WIRES 20 GA
2. GA WIRES 12 GA

PARTS LIST

ITEM	QTY -01	QTY -02	P/N	DESCRIPTION
1	1	0	1005042	ASSEMBLY, TIMER RELAY HARNESS (12V SYSTEM)
2	0	1	1005043	ASSEMBLY, TIMER RELAY HARNESS (24V SYSTEM)
3	1	1	R-3	RING CONNECTOR
4	1	1	94F1671	MOLEX LARGE FEMALE CONNECTOR
5	2	2	66099-4	CRIMP PIN MALE

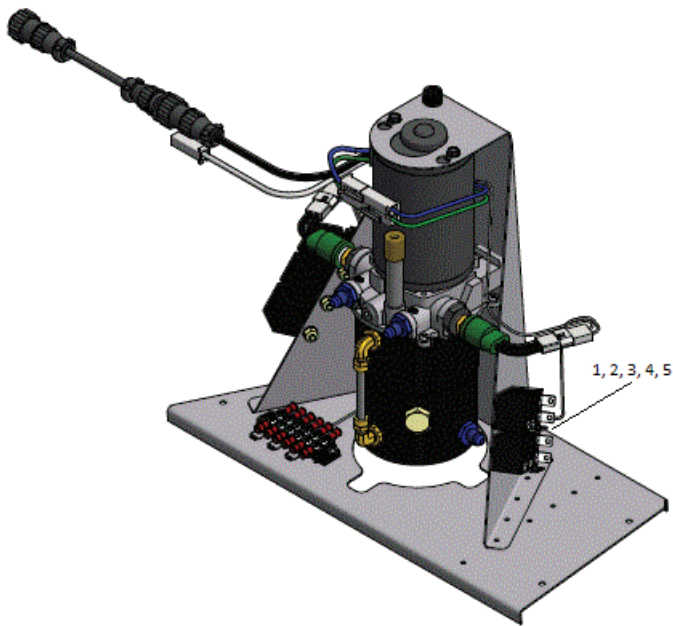

21A09000-210 (PA-18) (12V) -01
 21A09000-280 (PA-18) (24V) -02

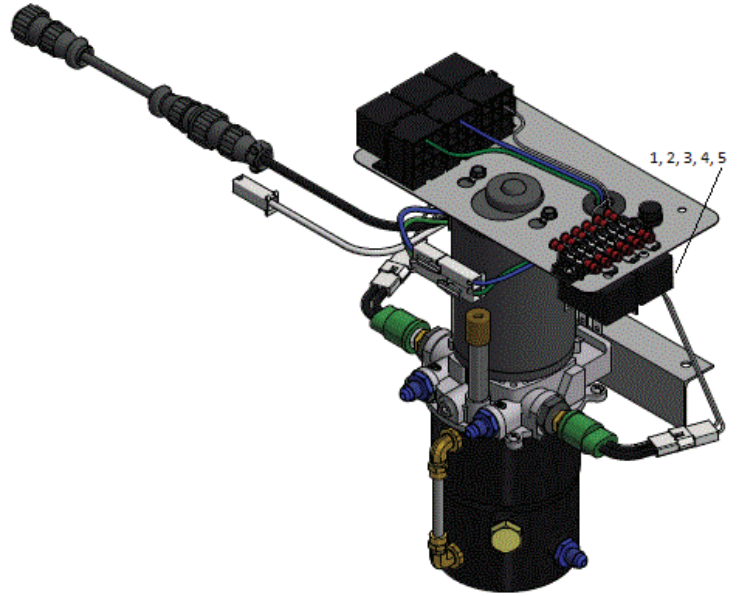

34A09000-245 (C-206) (12V) -01
 34A09000-277 (C-206) (24V) -02

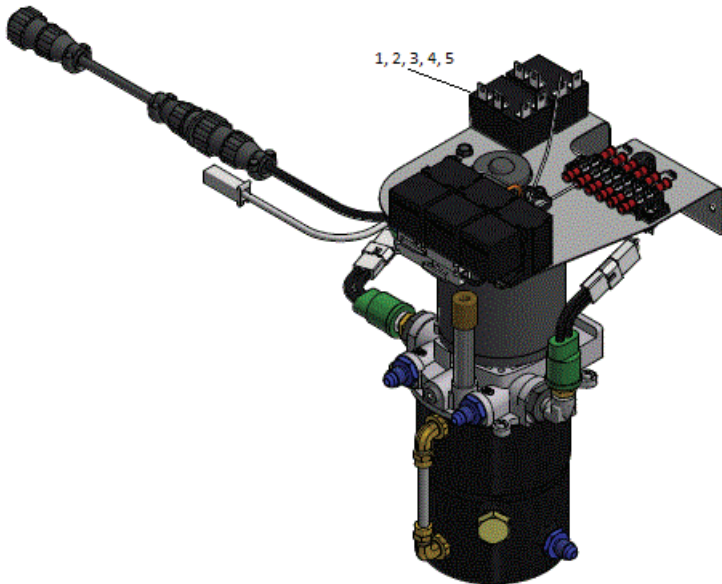

34A09000-266 (C-180) (C-185) (12V) -01
 34A09000-281 (C-180) (C-185) (24V) -02

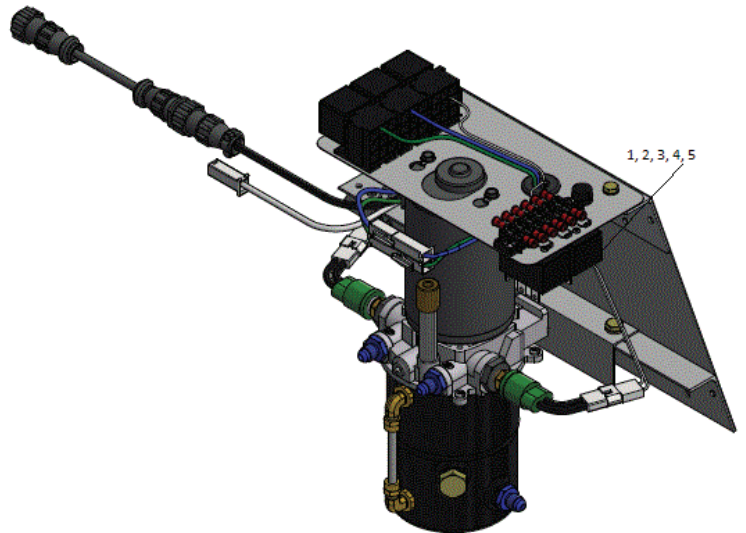

21A09000-195 (HUSKY) (12V) -01

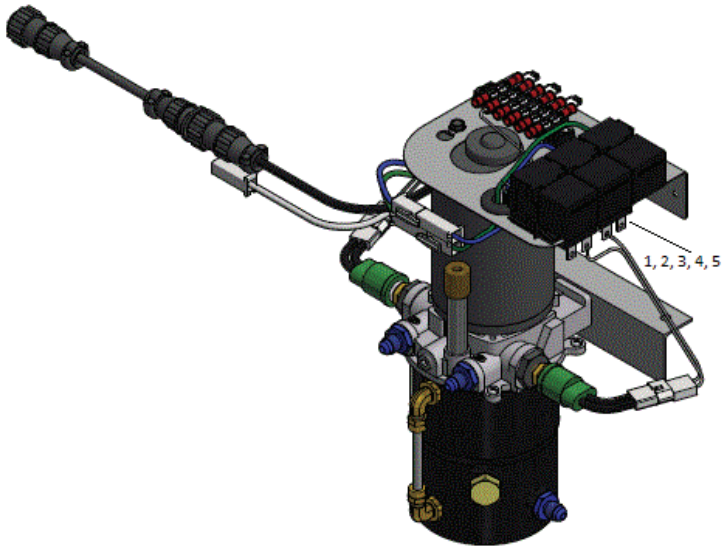

21A09000-239 (C-172) (C-182) (12V) -01
21A09000-283 (C-172) (C-182) (24V) -02

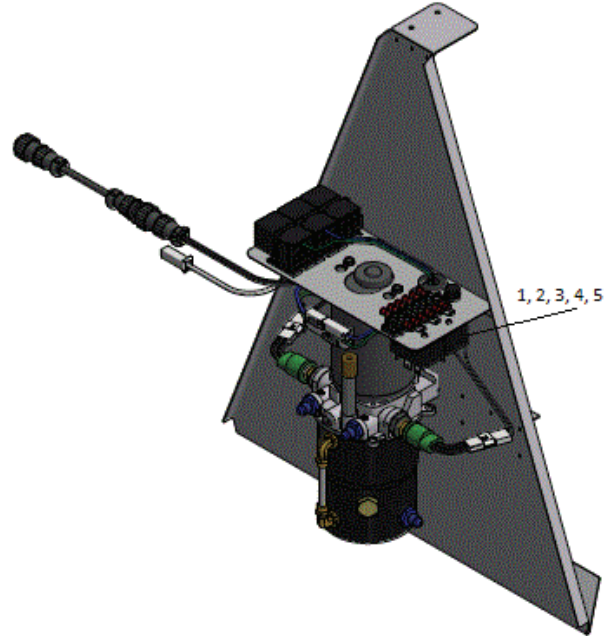

21A09000-216 (8GCBC) (7GCBC) (12V) -01

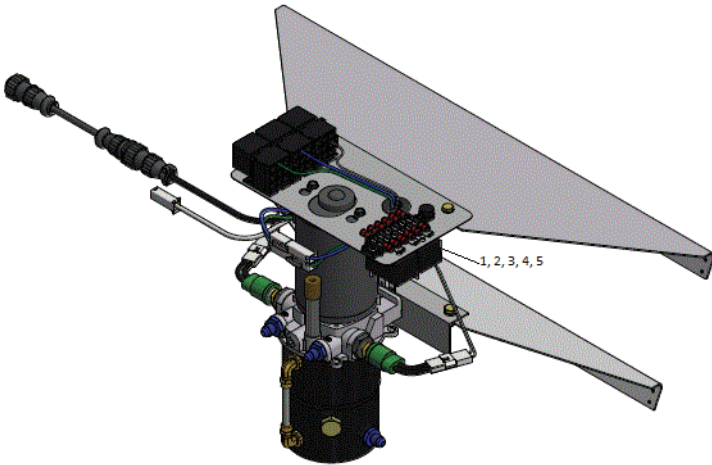

21A09000-288 (HUSKY - EXTENDED BAGGAGE) (12V) -01

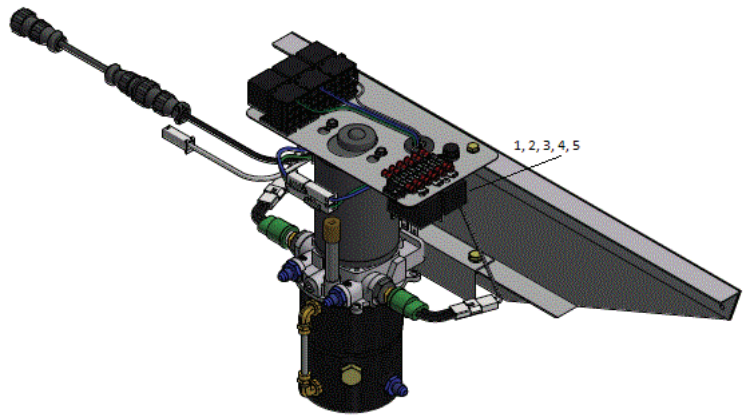

23A09000-225 (MAULE) (12V) -01
23A09000-276 (MAULE) (24V) -02