

SERVICE LETTER NUMBER 144			
TITLE: DRAG STRUT ATTACHMENT, WASHER REPLACEMENT			
BY: MAB	AIRCRAFT MAKE/MODEL(S):	FLOAT MODEL(S):	NOTE(S):
APP: SDW	FIREBOSS AIR TRACTOR 802 & 802A	10000	MANDATORY COMPLIANCE S/L P/N 1005968
DATE: 5/21/2019			
REV: C.1			

FAA APPROVAL HAS BEEN OBTAINED FOR TECHNICAL DATA IN THIS PUBLICATION THAT AFFECTS STC OR TSO DESIGN COMPLIANCE

EFFECTIVITY:

This service letter applies to all S/N 10126A and prior Wipline model 10000 amphibian floats, as installed on "Fireboss" Air Tractor 802 and 802A aircraft. This service letter applies to Air Tractor 802/802A aircraft equipped with STC SA01795CH.

COMPLIANCE:

Service letter compliance required at next annual service.

BACKGROUND:

The bolted attachment of the drag strut to the float has been found to cause coning of the flat washers both under the bolt head and the nut. Deformation of the washers in turn results in a loose bolted attachment.

COMPLIANCE METHOD:

Removal and replacement of the two (2) standard NAS1149F0863P flat washers in the float to drag strut attachment with high strength MS20002-8 plain washers.

APPROX. SHOP HOURS:

This service letter will take approximately 2-4 labor hours to complete.

WARRANTY INFORMATION:

Parts and labor warranty is not included for this modification.

Obsolete Superseded By Service Letter 182

TECHNICAL DATA:

Copies of this service letter, float service manual, and float parts manual are available on the website www.wipaire.com.

For basic model 10000 maintenance information, see Wipaire Service Manual P/N 1002545 for AT-802A and P/N 1003546 for AT-802.

For basic model 10000 parts information, see Wipaire Parts Manual P/N 1002179.

NOTES: Figure 1 shows the attachment location in question and Figure 2 details the hardware replacement that must be made.

1. Position aircraft safe for maintenance.
2. Provide for support of float and remove Drag Strut attachment nut, bolt, and washers.

Note: Inspect drag strut attach point for hole elongation. If hole is found to be elongated, comply with service letter 145 (P/N 1005968).

3. Replace existing NAS1149 washers with MS20002 washers and reinstall bolt. Re-torque to 480-690 in-lbs (40-57.5 ft-lbs).

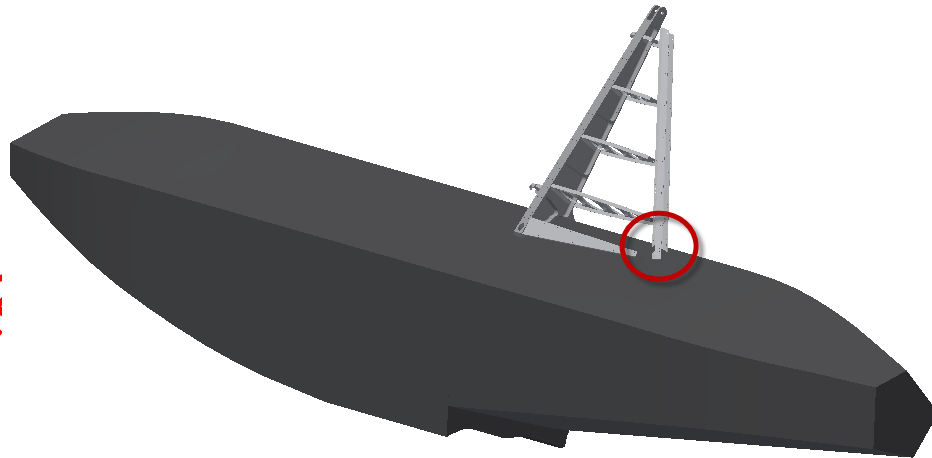
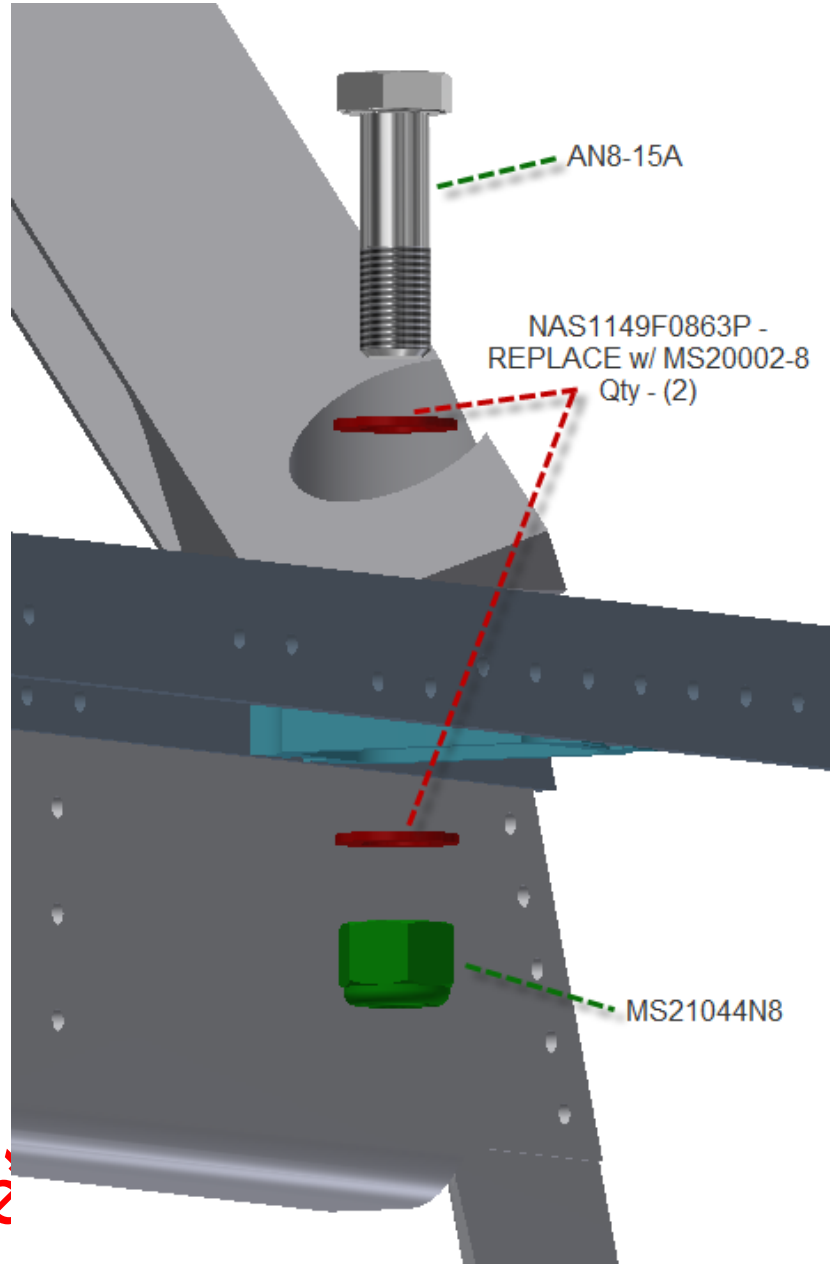

Figure 1: Attachment Location (Strut Fairings Removed)



Obsolescence

Letter 182

Figure 2: Hardware Replacement Detail

END