



WIPLINE FLOATS • SKIS • MODIFICATIONS • AIRCRAFT SALES  
 AVIONICS • INTERIOR • MAINTENANCE • PAINT REFINISHING

## SERVICE LETTER 171 8750A MAIN GEAR OIL BATH WHEEL SYSTEM

<b>By:</b> RCG	<b>Aircraft Makes/Model(s):</b>  Cessna 208 Cessna 208B	<b>Float Model(s):</b>  8750A	<b>Note(s):</b>  Optional Compliance Service Letter P/N 1008943
<b>Approved:</b> JRS			
<b>Date:</b> 1/23/2018			
<b>Revision:</b> D			

### LOG OF REVISIONS

Revision	Description	Date
A	Initial release	10/24/2016
B	<ul style="list-style-type: none"> <li>• Changed serial effectivity from 87190 and prior to 87176 and prior</li> <li>• Changed AN3-4 to AN3-5 in reservoir installation</li> <li>• Changed approximate shop hours</li> <li>• Changed NAS1149D0763P to NAS1149D0763J and NAS1149F0363P to NAS1149D0363J</li> <li>• Added note allowing installation of drain cap on inboard or outboard side</li> <li>• Added "or equivalent" to new grease seal</li> <li>• Added instruction to apply Tef-Gel and Loctite to certain hardware in instruction</li> <li>• Changed AN526-832R5 to AN526C832R8 and AN526-832R4 to AN526C832R6</li> <li>• Placards 1009112, 1009113 modified</li> <li>• Added "one kit per float set" to Table 1</li> <li>• Added weight and balance specifications</li> <li>• Corrected new molded grease seal to 154-08200 or equivalent</li> <li>• Changed BOM Part Number 1008995 to 1008995-01 Kit</li> </ul>	7/17/2017
C	<ul style="list-style-type: none"> <li>• Drilled axle now provided with service kit</li> <li>• Added parent kit part number to bill of materials</li> </ul>	11/2/2017
D	<ul style="list-style-type: none"> <li>• Corrected 1008980 axle quantity in 1008943-01 kit from 1 to 2</li> <li>• Corrected trunion bolt from AN10-40A to AN10-40</li> </ul>	1/23/2018

FAA approval has been obtained for technical data in this publication that affects STC or TSO design compliance

**EFFECTIVITY:**

This service letter applies to: Cessna 208 and Cessna 208B with Wipline 8750 Amphibious Floats SN 87176 and prior installed per STC SA1311GL

**COMPLIANCE:**

Optional compliance

**BACKGROUND:**

A new main gear oil bath wheel bearing system has been designed to replace the old main gear grease wheel system. This new system will allow the wheel bearings to be continuously lubricated, which will increase the life of the wheel bearings

**COMPLIANCE METHOD:**

Install new main gear oil bath wheel system per Work Instruction section of this service letter. If revision A has been complied with, no further action is needed

**APPROXIMATE SHOP HOURS:**

Installing the main gear oil bath wheel system will take approximately 25 hours not including cure time of products used

**WARRANTY INFORMATION:**

Parts and labor not included for this modification. Contact Wipaire customer service to purchase the kit

**TECHNICAL DATA:**

Copies of this service letter, float service manual, and float parts manual are available at [www.wipaire.com](http://www.wipaire.com)

See photos and figures below for details to aid in performing this modification

See Table 1 below for a list of parts included in the service kit

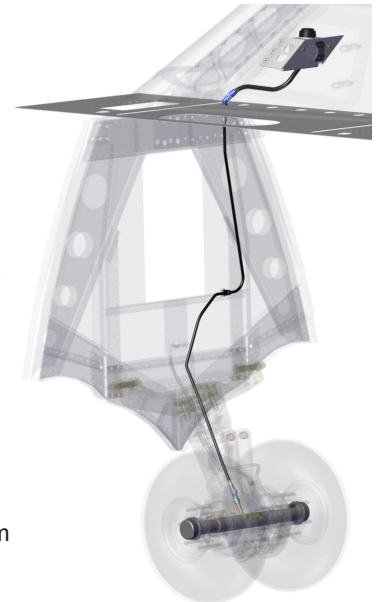

1700 Henry Ave - Fleming Field (KSGS), South St. Paul, MN 55075

Phone: 651.451.1205 | Fax: 651.457.7858

[www.wipaire.com](http://www.wipaire.com)

**ITEMS PROVIDED IN SERVICE KIT (ONE KIT PER FLOAT SET)**

ITEM	QTY	PART NUMBER	DESCRIPTION
-	1	1008943-01	KIT, SERVICE LETTER 171: 8750A MAIN GEAR OIL BATH WHEEL SYSTEM
1	1	1008995-01	KIT, OIL BATH WHEEL RESERVOIR INSTALLATION ASSEMBLY
2	1	1009155	LH OIL RECEPTACLE BRACKET ASSEMBLY
3	1	1009156	RH OIL RECEPTACLE BRACKET ASSEMBLY
4	2	1009152	HYDRAULIC HOSE ASSEMBLY
5	2	MS21919WDG5	CLAMP
6	2	AN526C1032R10	MACHINE SCREW
7	4	NAS1149D0363J	WASHER
8	2	MS21044N3	NUT
9	4	NAS1149D0763J	WASHER
10	1	PR-1422-B-2-654	SEALANT SEM KIT 6 OZ.
11	2	AN837-4D	ELBOW FLARED TUBE
12	2	AN924-4D	JAM NUT
13	2	AN929-4	CAP
14	2	1008983	THREADED BRASS FITTING
15	4	600-0030-1/4	STAT-O-SEAL WASHER
16	4	750-0030-1/4	THREDSEAL WASHER
17	2	AN816-4D	FLARED TUBE AND PIPE THREAD ADAPTER
18	2	AN910-1D	COUPLING
19	4	1008977	OIL BATH INNER WHEEL RETAINER
20	8	AS568A-139	O-RING
21	2	1008984	HUB CAP ASSEMBLY WITH DRAIN HOLE
22	2	1008985	HUB CAP ASSEMBLY WITHOUT DRAIN HOLE
23	4	154-08200 or equivalent	MOLDED GREASE SEAL
24	2	PLT3S-M0	CABLE TIE
25	1	24221	LOCTITE 10 ML BOTTLE
26	4	MS21044N4	NUT
27	4	AN526C832R6	SCREW
28	6	AN526C832R8	SCREW
29	2	MS21044N12	NUT
30	4	MS24665-349	COTTER PIN
31	4	MS24665-376	COTTER PIN
32	1	1009164	OIL BATH WHEEL FILLER ASSEMBLY
33	2	1008980	AXLE, MAIN GEAR, OIL BATH WHEEL

**TABLE 1**

## WORK INSTRUCTION

1. Per Wipaire maintenance manual, jack aircraft to relieve load on the main gear
2. Pull gear pump circuit breakers
3. Pull parking brake valve in cockpit
4. Remove the main gear drag link assembly from the float in the order shown below:

Set aside all removed hardware to use during re-installation unless noted to discard in the instruction or replace hardware as needed

a. Disconnect brake lines at bulkhead 10 and cap and plug lines at both ends

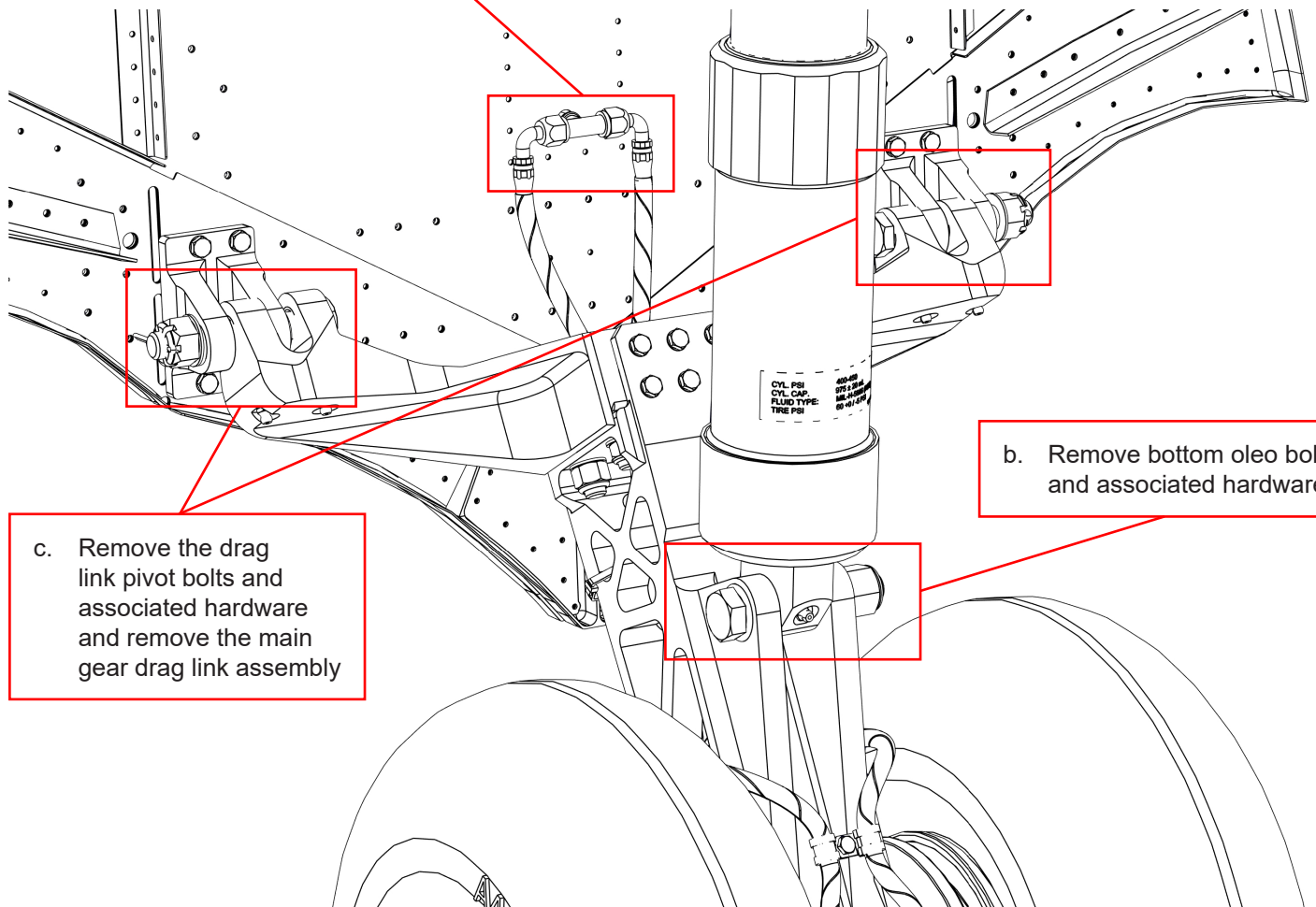

b. Remove bottom oleo bolt and associated hardware

c. Remove the drag link pivot bolts and associated hardware and remove the main gear drag link assembly

### MAIN GEAR DRAG LINK ASSEMBLY REMOVAL

## WHEEL ASSEMBLY REMOVAL

5. Cut safety wire on caliper backplate assembly bolts and remove brake back plate assemblies
6. Remove and discard cotter pin and remove axle nut and main wheel axle spacer
7. Slide each main wheel assembly off main wheel axle
8. Remove brake calipers, keeping the brake line assemblies still attached to the calipers

## WHEEL DISASSEMBLY

9. Remove air from tire and break loose tire beads

### WARNING!

**Serious injury can result from attempting to separate wheel halves while tire and tube are still inflated.**

10. Remove (6) AN bolts and associated washers and nuts that hold the wheel halves and brake disc together
11. Split wheel halves and remove tire assembly
12. Remove snap ring, bearing seals, and bearing cone from each wheel half
13. Remove the following components from the current wheel assembly:

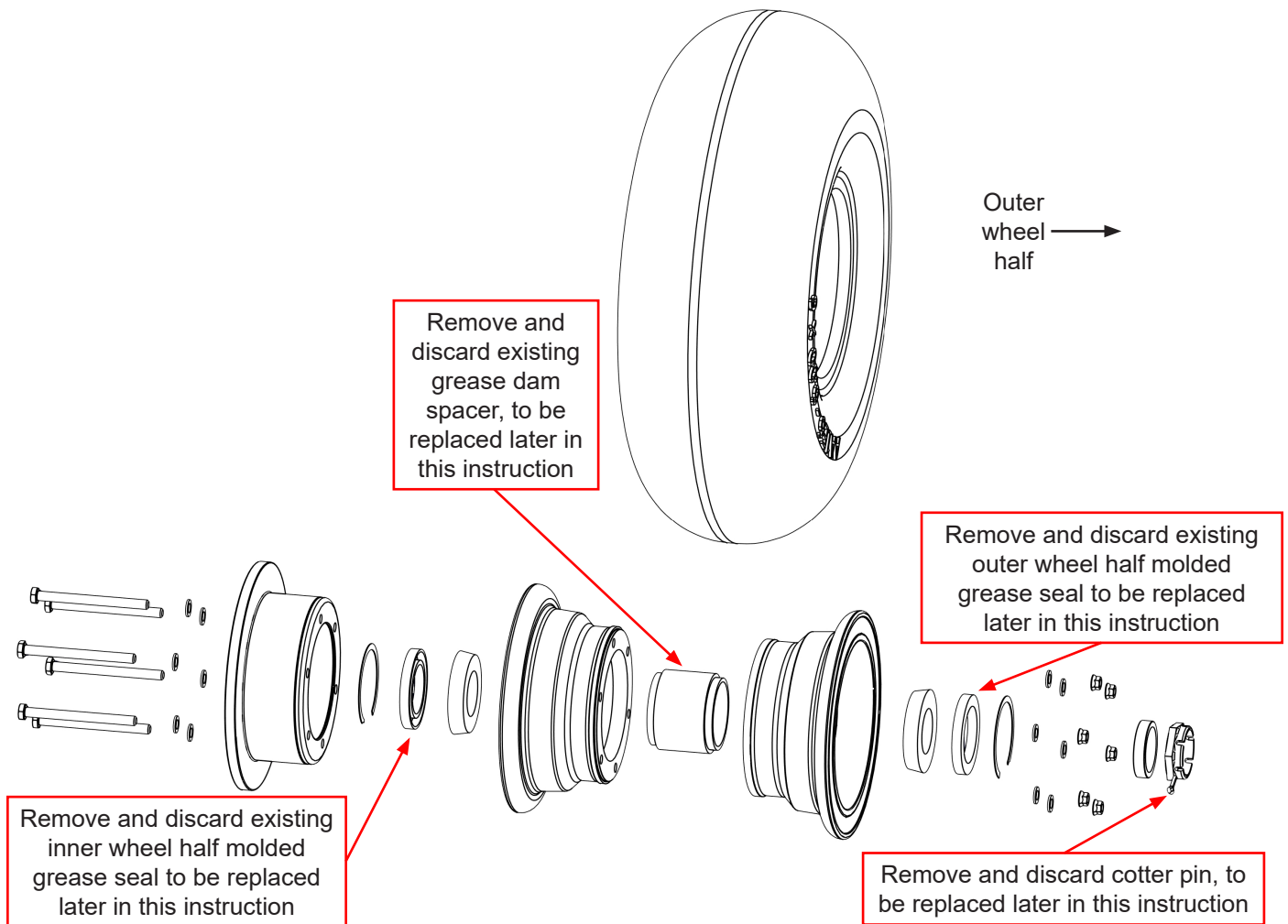

**CURRENT WHEEL ASSEMBLY**

14. Clean existing grease from wheel and bearing cavities

**Note:** Grease does not need to be completely cleaned out as it will not affect the oil bath wheel system bearing lubrication

15. Inspect wheel assemblies and replace any worn components if needed

## WHEEL REASSEMBLY

16. Verify the index marking on tire aligns with the air valve on tube

17. Place inner wheel half into tire

18. Install (2) new AS568A-139 O-rings in grooves of 1008977 oil bath inner wheel retainer

19. Place outer wheel half into other side of tire with assembled 1008977 oil bath inner wheel retainer and attached O-rings between wheel halves

20. Insert thru-bolts, brake disc, and associated washers and nuts and torque to specifications provided by wheel manufacturer.

**NOTE:** Ensure tube and oil bath inner wheel retainer is not pinched between wheel halves prior to torquing hardware

21. Place the wheel and tire in an inflation cage and inflate tire to seat tire beads, then inflate or deflate to specifications provided by the wheel manufacturer

22. Assemble bearing cone, new grease seal, and snap ring into the inner wheel half

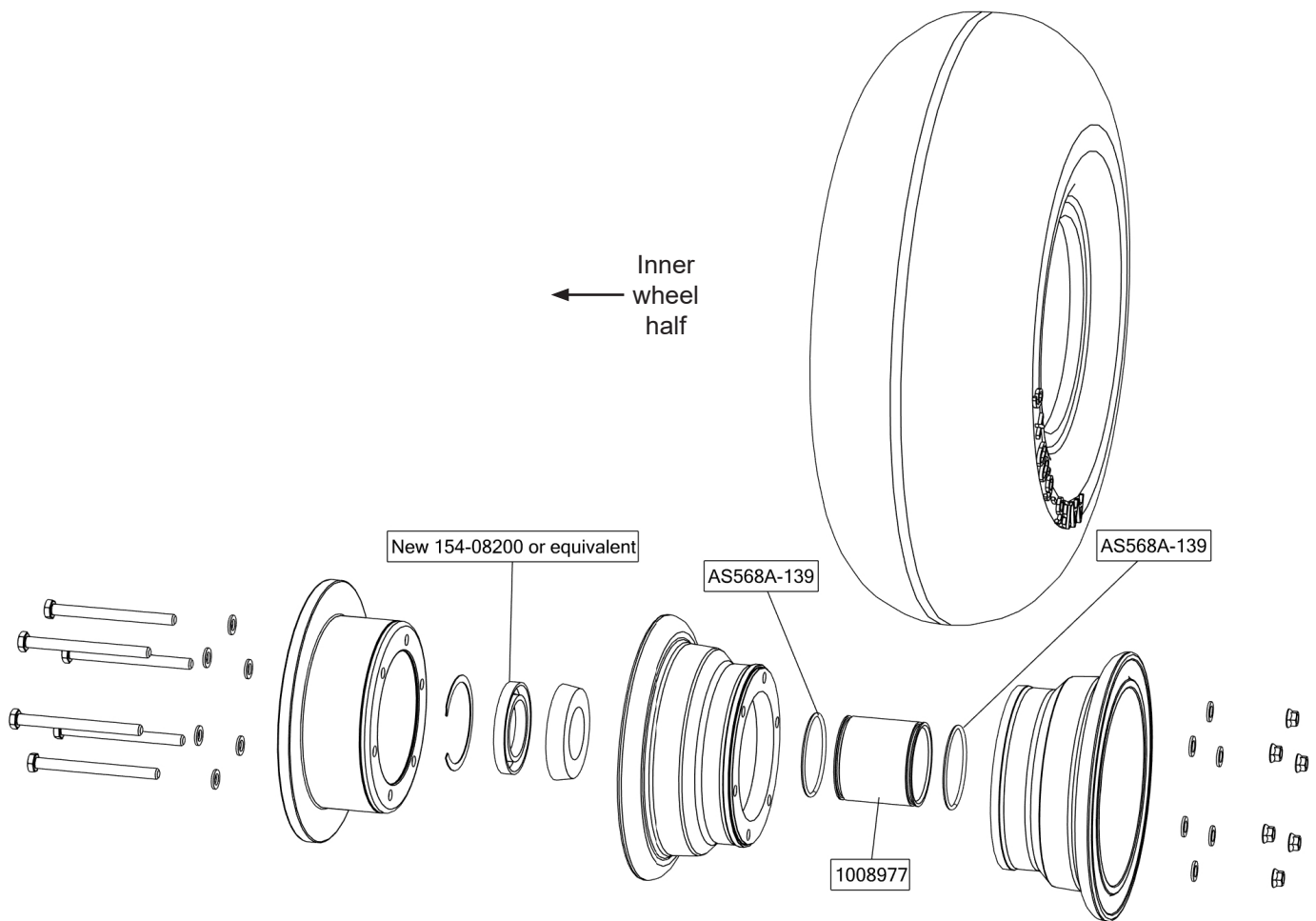

**WHEEL REASSEMBLY**

## AXLE REMOVAL

23. Remove the torque plates from the main gear drag link by removing (6) MS16997-77 and (6) MS16997-96 screws, and (4) 30A04523-002 torque plate bushings
24. Remove (2) AN4-33A bolts and associated washers and nuts that secure the axle to the main gear drag link and remove axle out of main gear drag link

**NOTE:** Axle may need to be pressed out

## DRAG LINK REASSEMBLY

25. Install new 1008980 main gear axle into drag link after sealing the axle with Loctite Threadlocker Blue 242. Threadlocker must be applied liberally such that mating surfaces are 100% wetted. Rotate and maneuver axle back and forth in drag link to assure threadlock is completely spread and contacting all points between the axle and the drag link
26. Reinstall (2) AN4-33A bolts with new 600-0030-1/4 and 750-0030-1/4 stat-o-seal washers, and (2) new MS21044N4 nuts that secure the axle to the main gear drag link

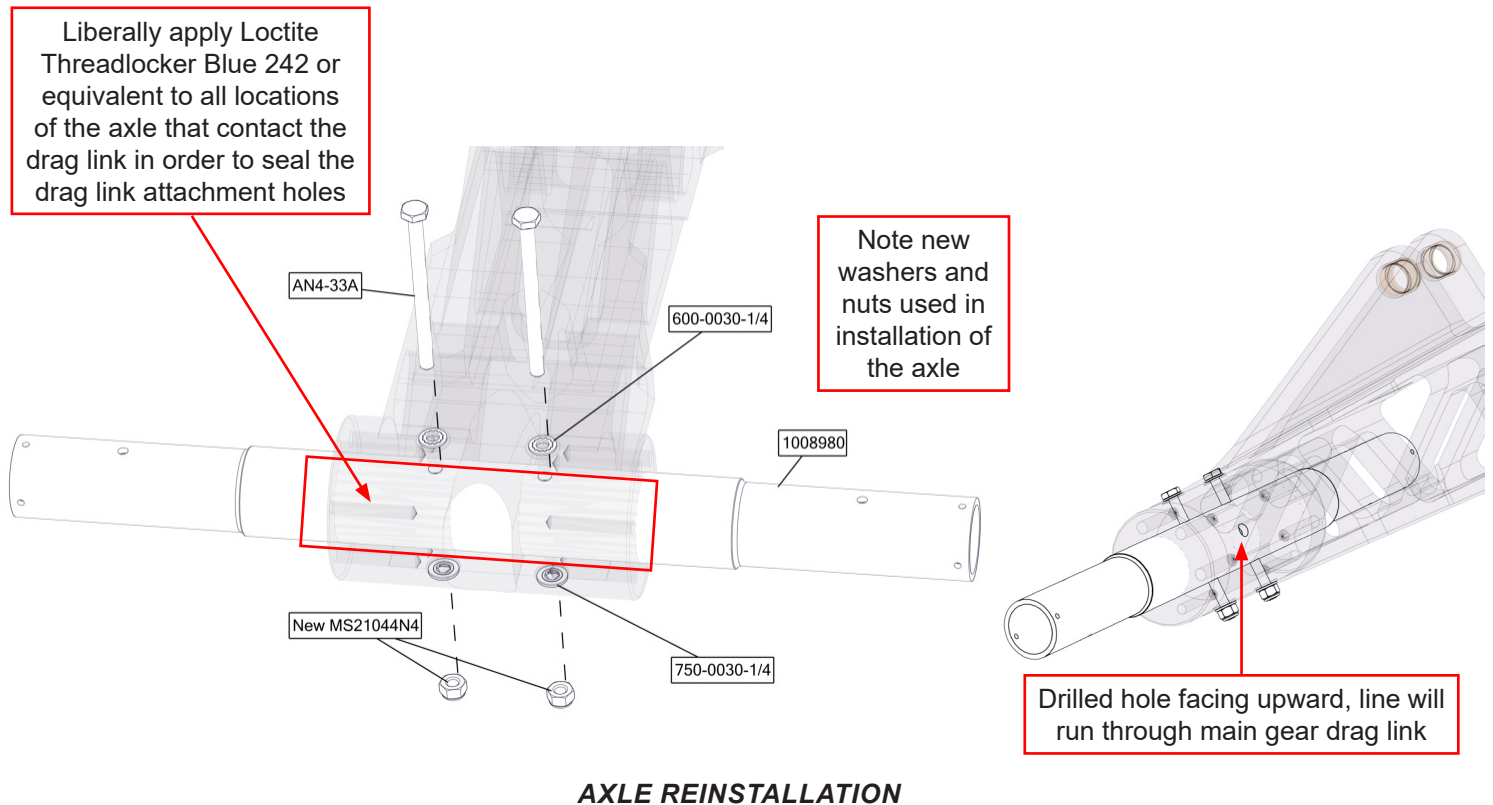

27. Reinstall torque plates using (6) MS16997-77 (with Tefgel applied), (6) MS16997-96 screws (with Loctite applied), and (4) 30A04523-002 torque plate bushings

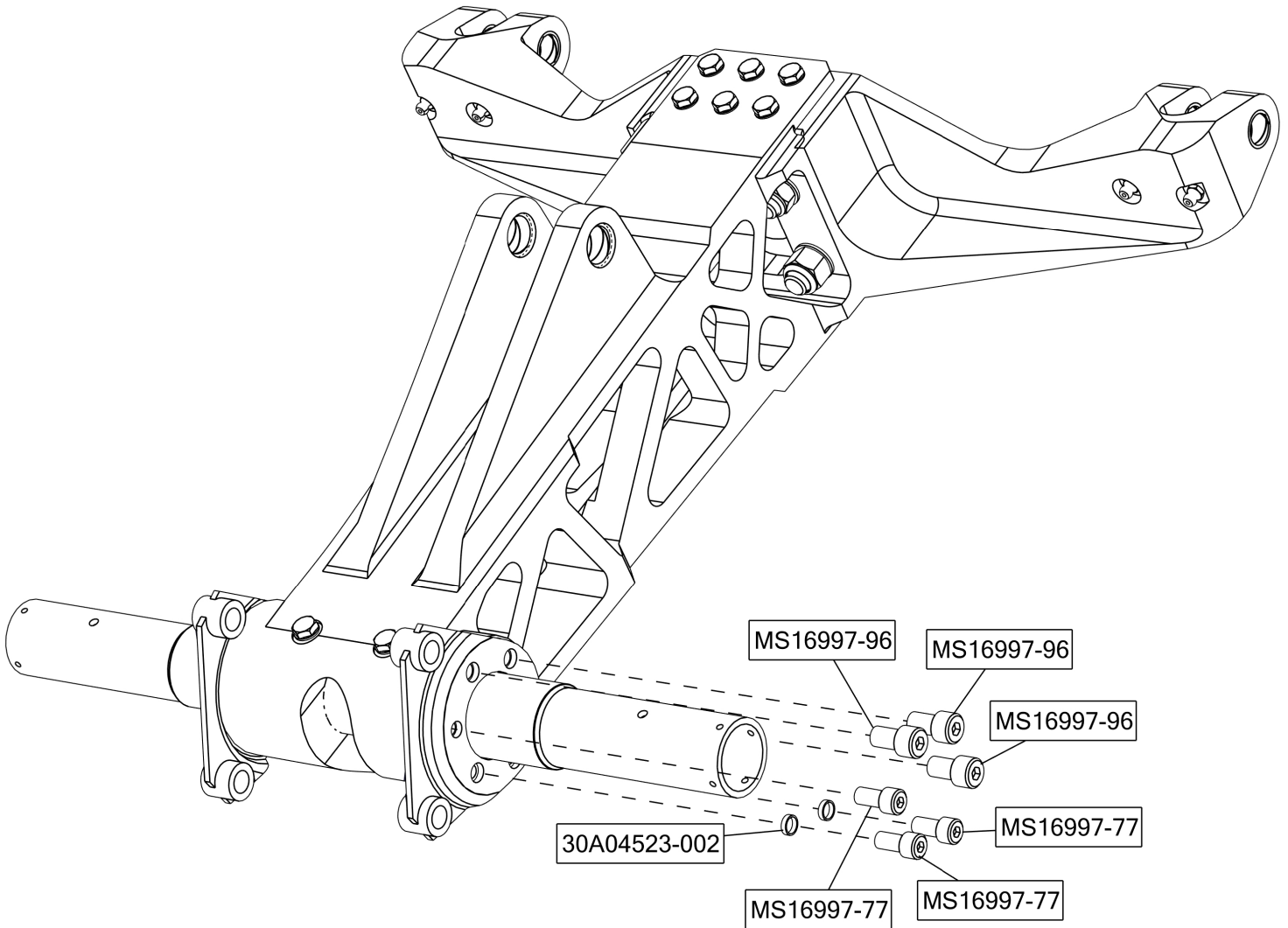

## HOSE ROUTING AND DRAG LINK REINSTALLATION

28. Apply 1422 sealant on threads of 1008983 threaded brass fitting, AN910-1D coupling, and AN816-4D flared tube and pipe thread adapter and install into axle as shown

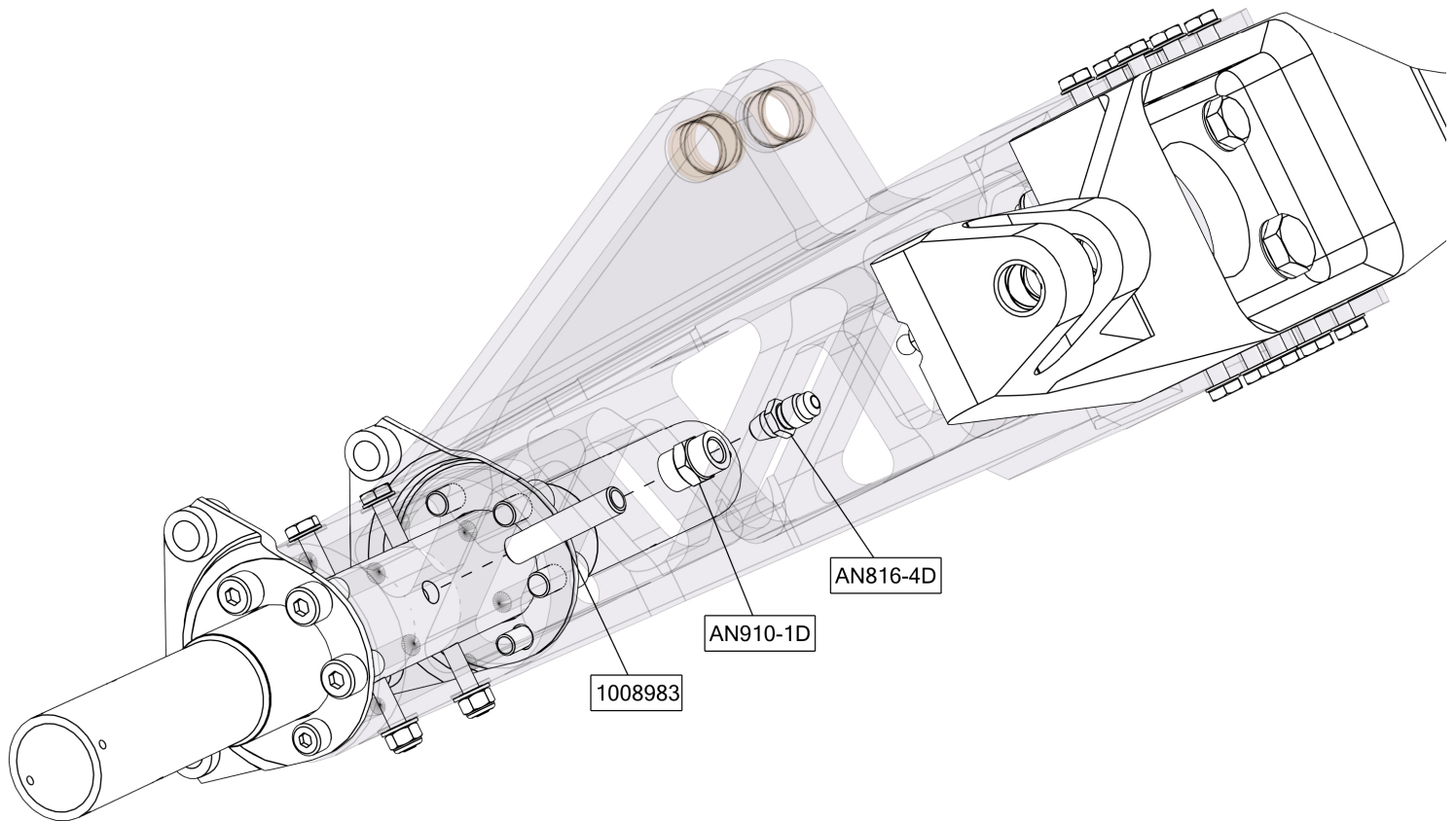

29. Corrosion treat all exposed hardware with Dinitrol AV30 or equivalent

**NOTE:** Allow previously applied 1422 sealant to dry completely per manufacturing specifications prior to applying Dinitrol AV30 or equivalent



30. Route the 1009152 hydraulic hose assembly through the center of the main gear drag link and attach to the AN816-4D flared tube and pipe thread adapter on the main wheel axle

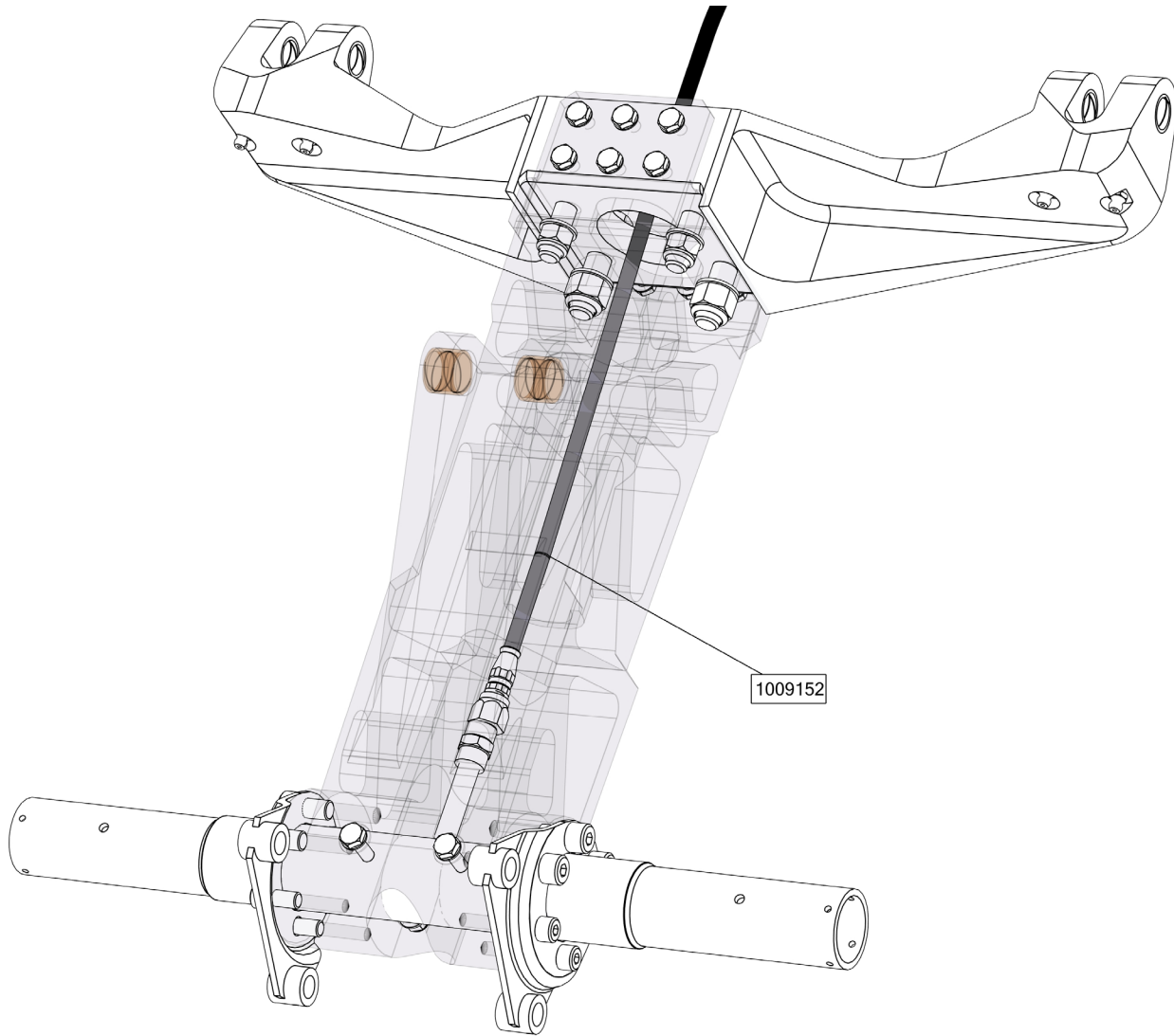

**HOSE TO AXLE INSTALLATION**

31. Route the brake lines and calipers. Secure brake lines to main gear drag link as shown

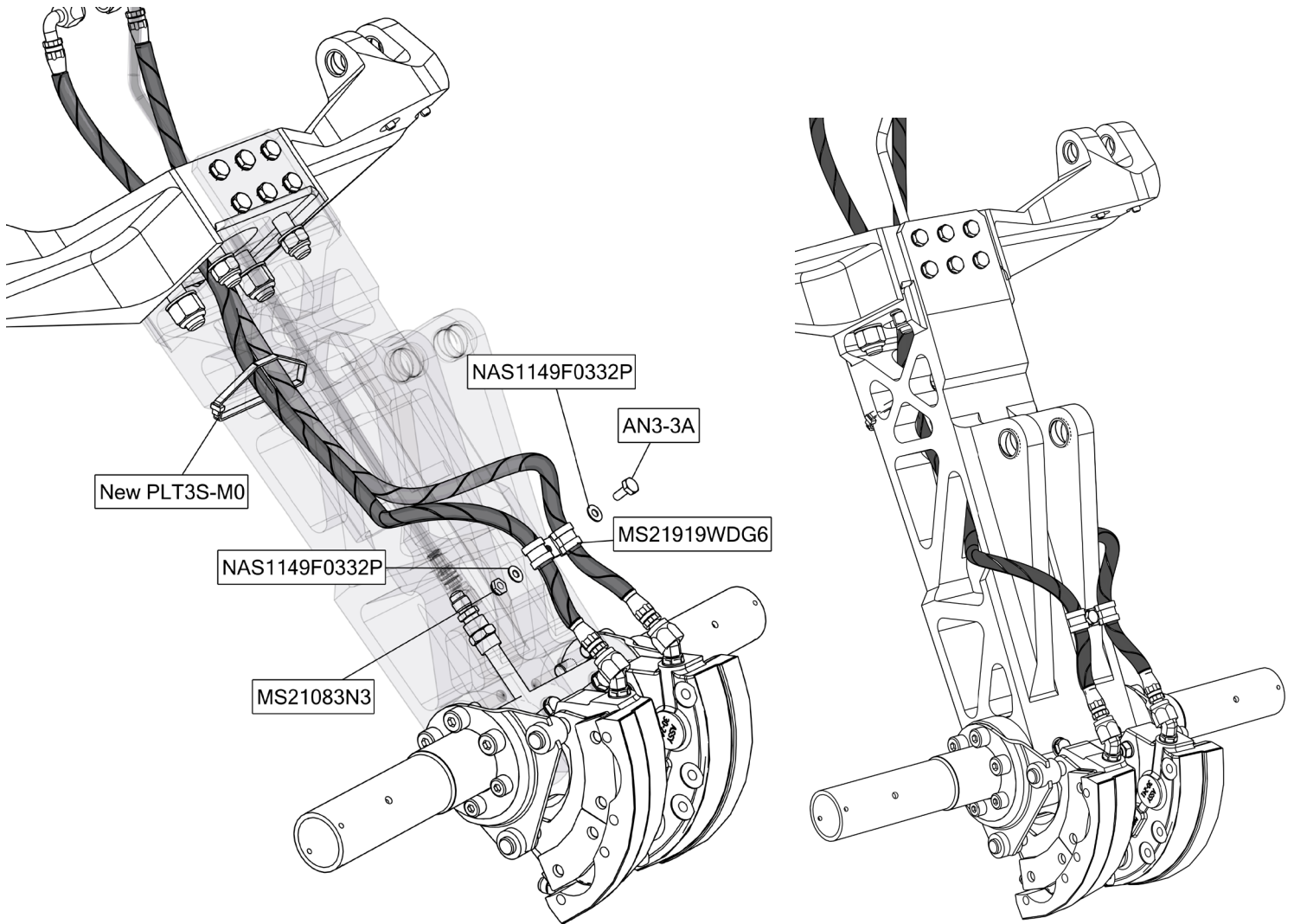

**BRAKE LINE ROUTING**

32. Carefully drill a  $\varnothing.45$  hole into the top deck using a 29/64 drill bit where shown

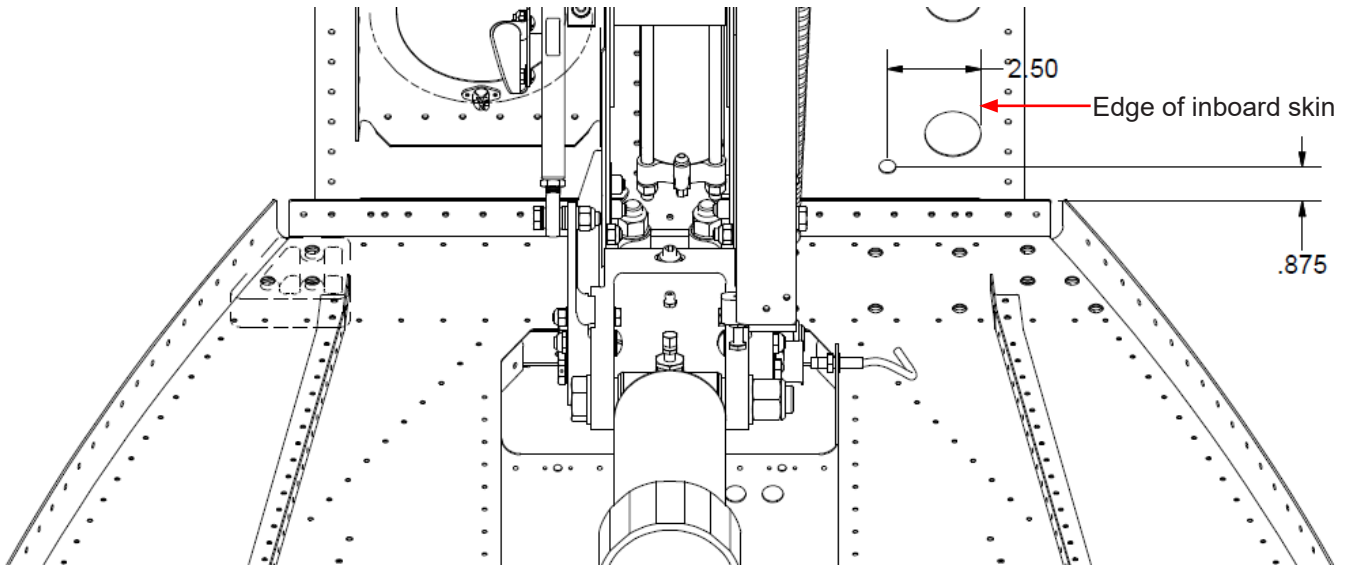
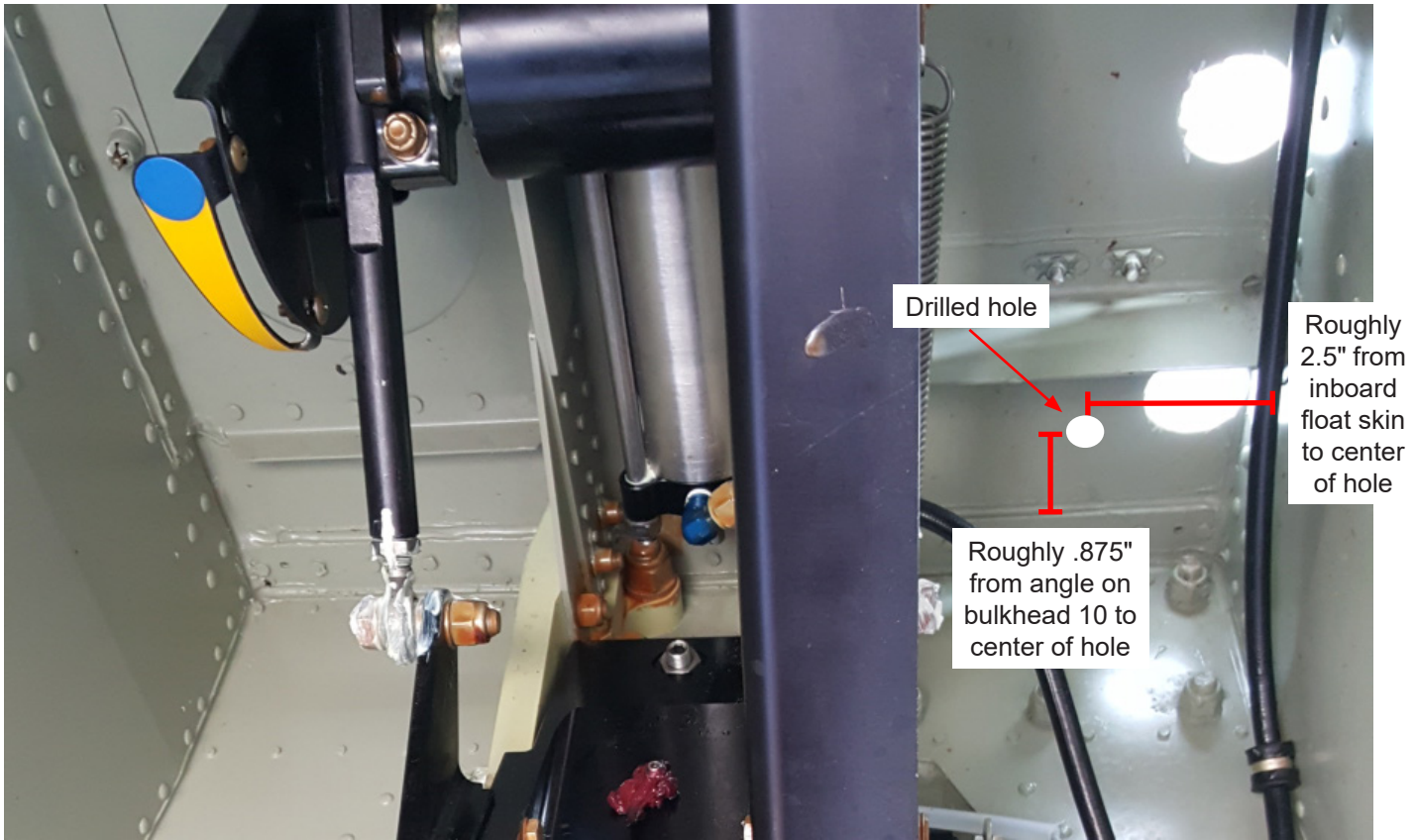

**TOP DECK HOLE LOCATION**

33. Install AN837-4D elbow flared tube, (2) NAS1149D0763J washers (with Tef-Gel applied), AN924-4D jam nut, and 63-190600-4 hose fitting as shown into previously drilled hole. Cap the top of fitting AN837-4D with AN929-4 cap until the hose is ready to be attached

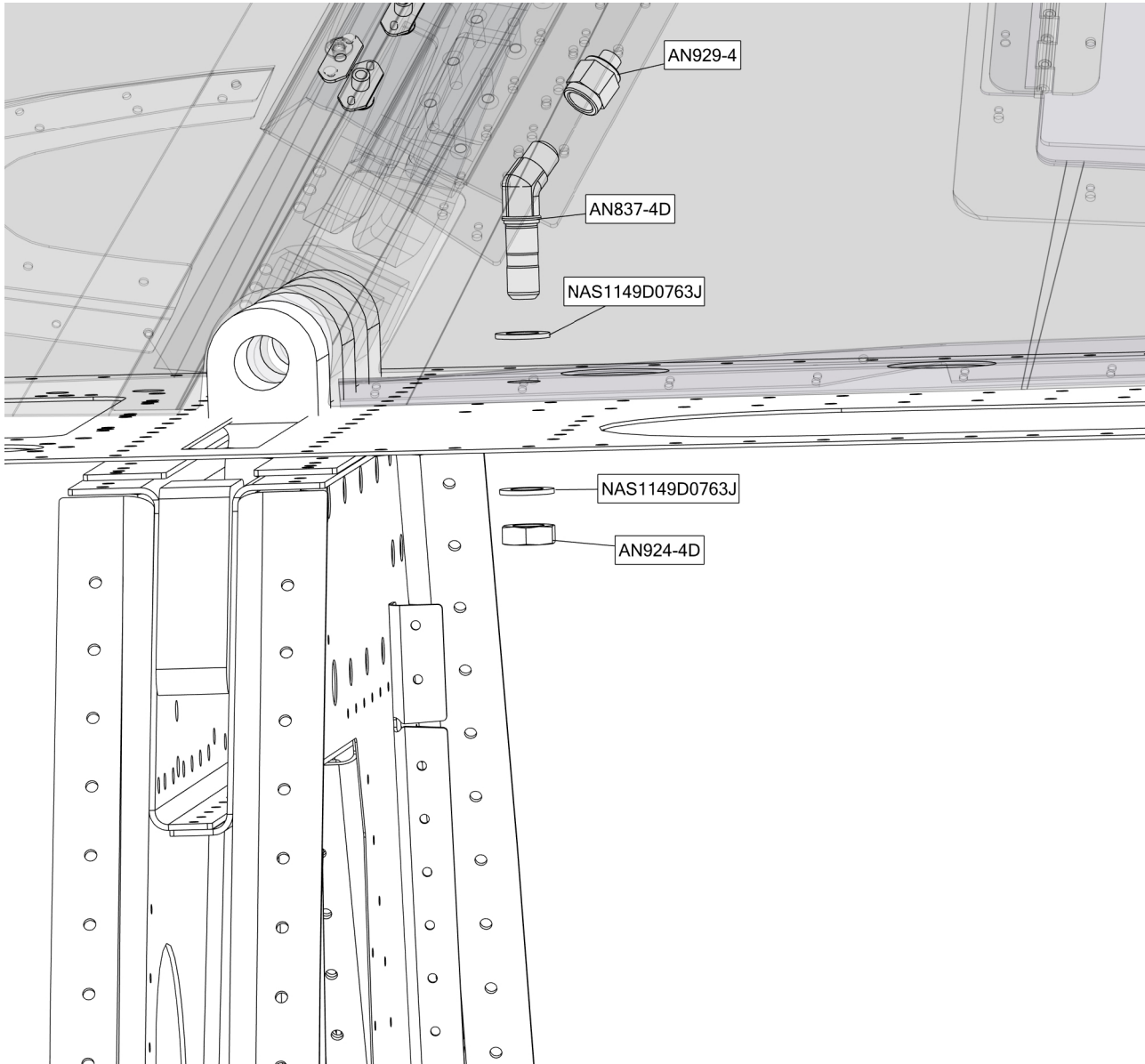

**TOP DECK HOSE FITTING ASSEMBLY**

34. Install the main gear drag link assembly and brake lines as shown below

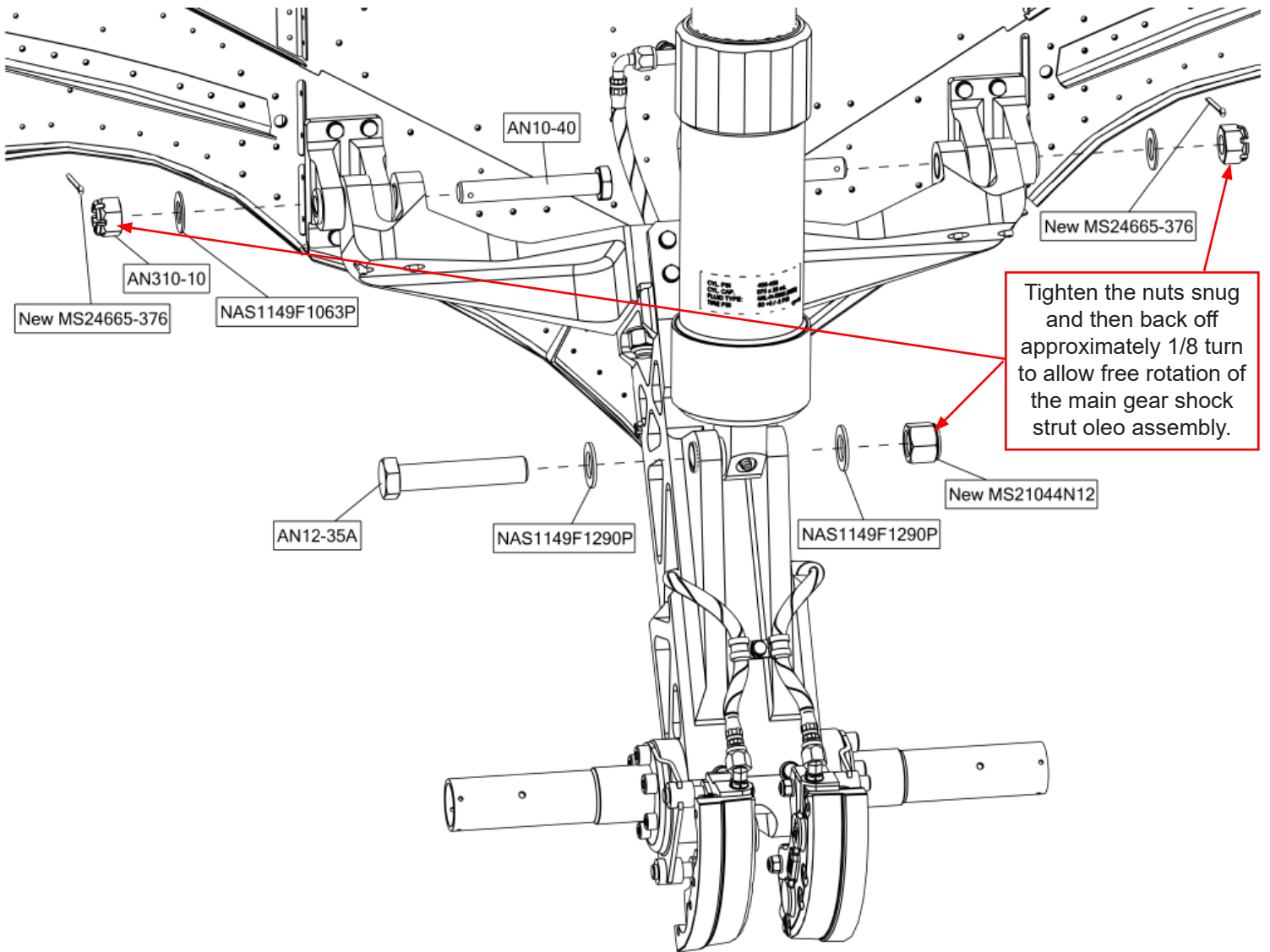

35. Grease the main gear zerks per service manual

36. Connect 1009152 hydraulic hose assembly to the top deck hose fitting and secure to bulkhead 10 assembly using AN526C1032R10 screw, (2) NAS1149D0363J washers, and MS21044N3 nut as needed such that it does not interfere with landing gear retraction

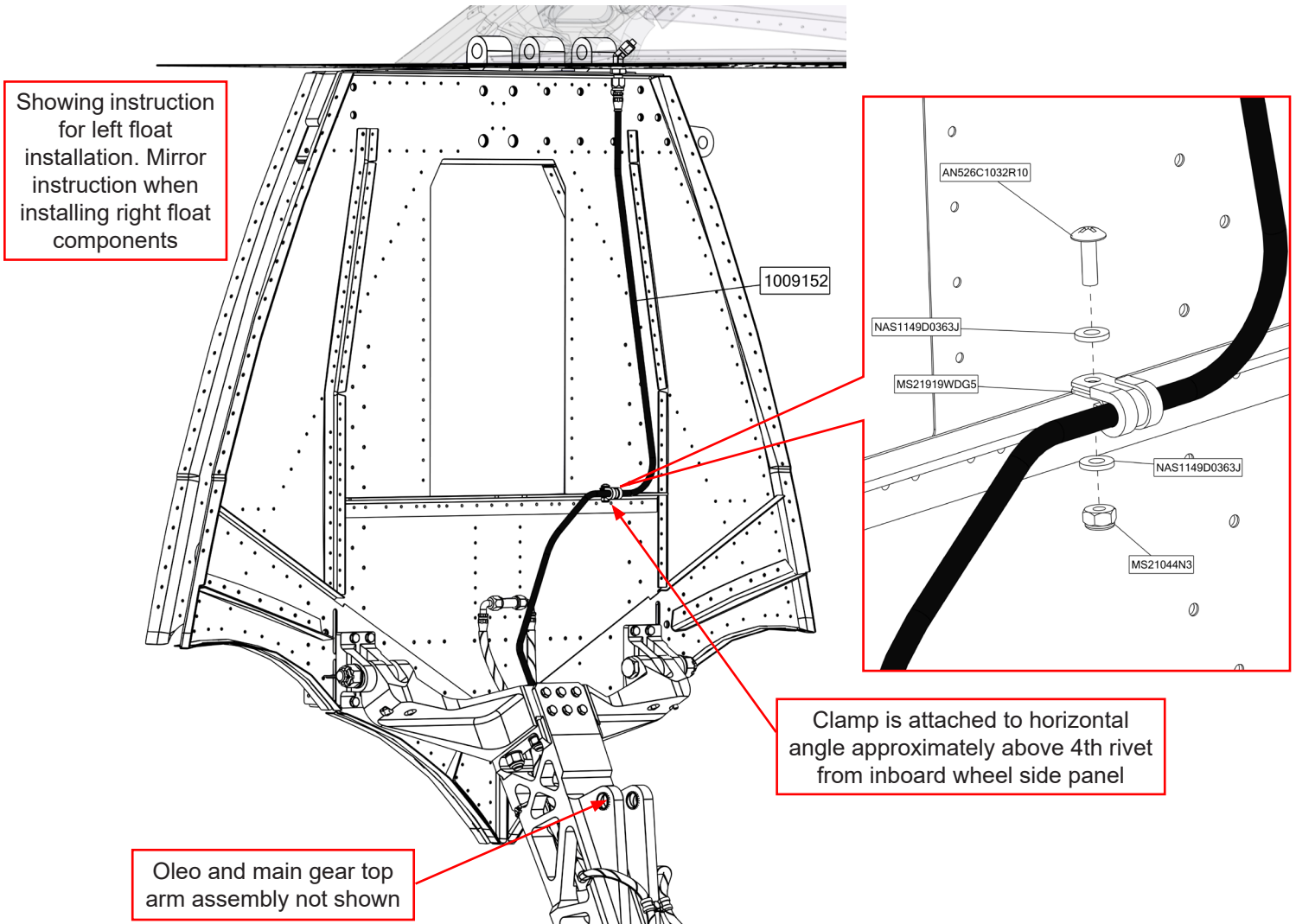

**HOSE LINE ROUTING TO BULKHEAD 10**

## WHEEL ASSEMBLY REINSTALLATION

**NOTE:** 1008984 hub cap assembly with drain hole can be located per the installer's discretion on either the outer wheel half of the inboard or outboard tire per main gear assembly. There must be (1) 1008985 hub cap without drain hole assembly and (1) 1008984 hub cap with drain hole assembly per (1) main gear assembly. **The following instruction shows a left float main gear installation with the 1008984 hub cap assembly with drain hole being installed on the outer wheel half of the inboard wheel.**

37. Slide main wheel assemblies onto main wheel axle
38. Install bearing cone, main wheel axle spacer, and axle nut until a slight bearing drag is obvious when wheel is rotated. Back the nut off to the nearest castellation and insert new cotter pin in a manner that the head will not interfere with the inner hub cap surface
39. Reinstall the back plate assemblies and torque to specifications provided by brake manufacturer
40. Attach safety wire to caliper backplate assembly bolts
41. Install 1008985 hub cap without drain hole assembly to outer wheel half of outboard wheel using 155-14300 snap ring
42. Install 1008984 hub cap with drain hole assembly to outer wheel half of inboard wheel using 155-14300 snap ring

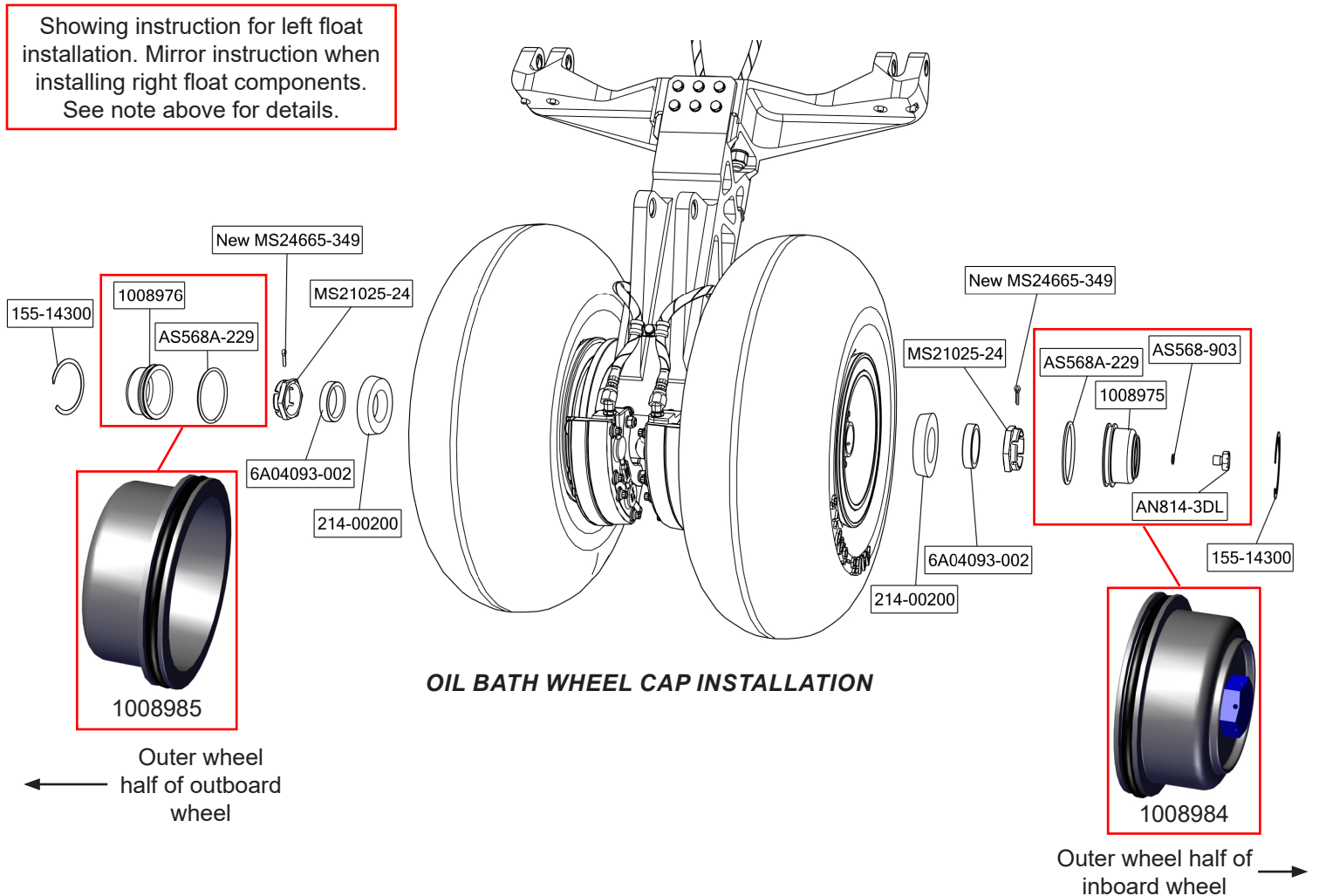

## RESERVOIR INSTALLATION

43. Remove the 3 middle rivets from the pylon door hinge and use a #29 drill bit to upsize the 3 holes
44. Attach 1009155 reservoir bracket assembly (1009156 for right pylon) and attach bracket with (3) AN526C832R8 screws

Showing instruction for left float installation. Mirror instruction when installing right float components

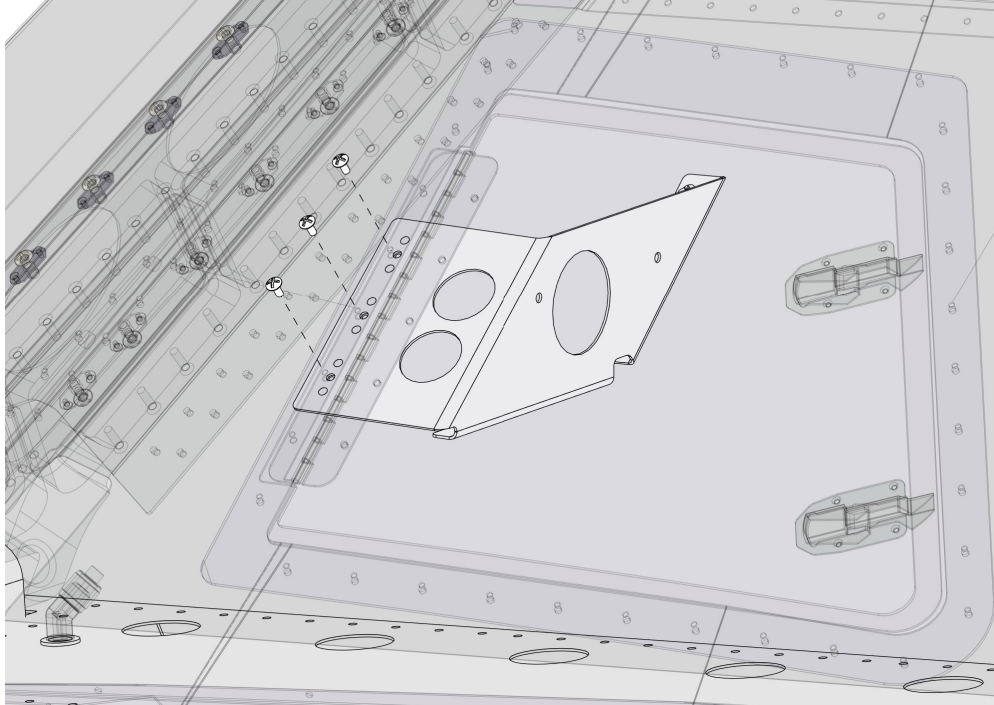

45. Mark inboard pylon skin through the center hole of each nutplate

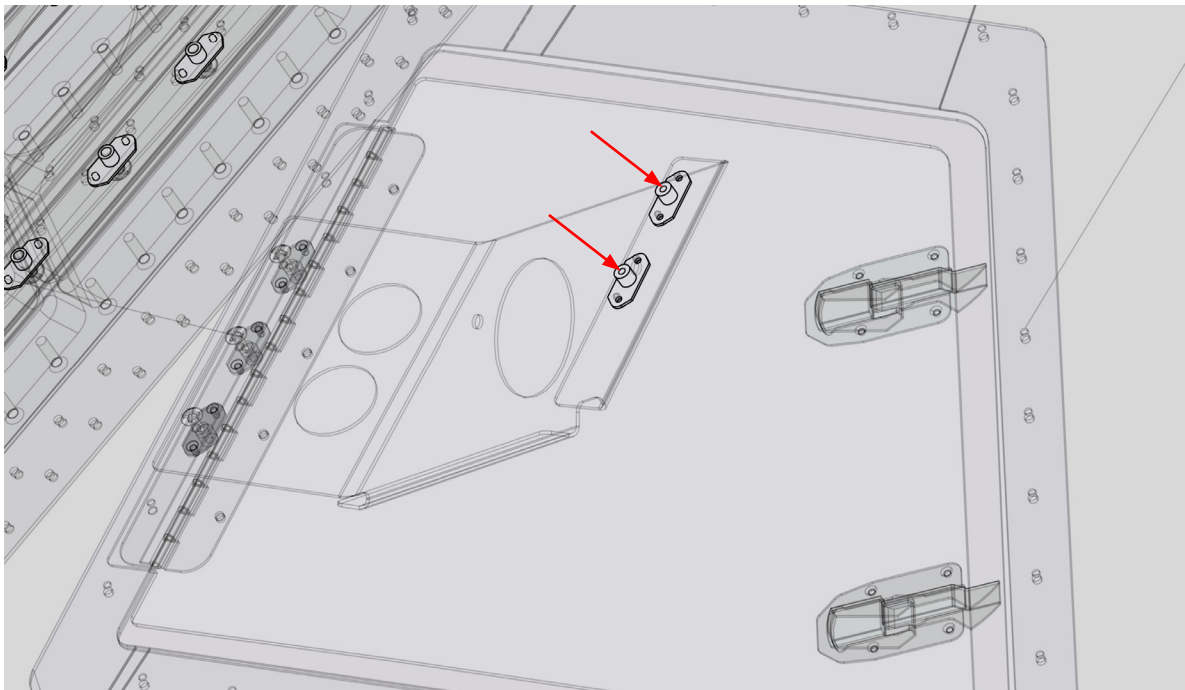



46. Remove reservoir bracket and drill the marked holes with a #29 drill bit
47. Deburr drilled holes
48. Attach the 1008992 oil bath wheel reservoir assembly to the bracket with (2) MS21044N3 nuts, (4) NAS1149D0363J washers, and (2) AN3-5A bolts

Showing instruction for left float installation. Mirror instruction when installing right float components

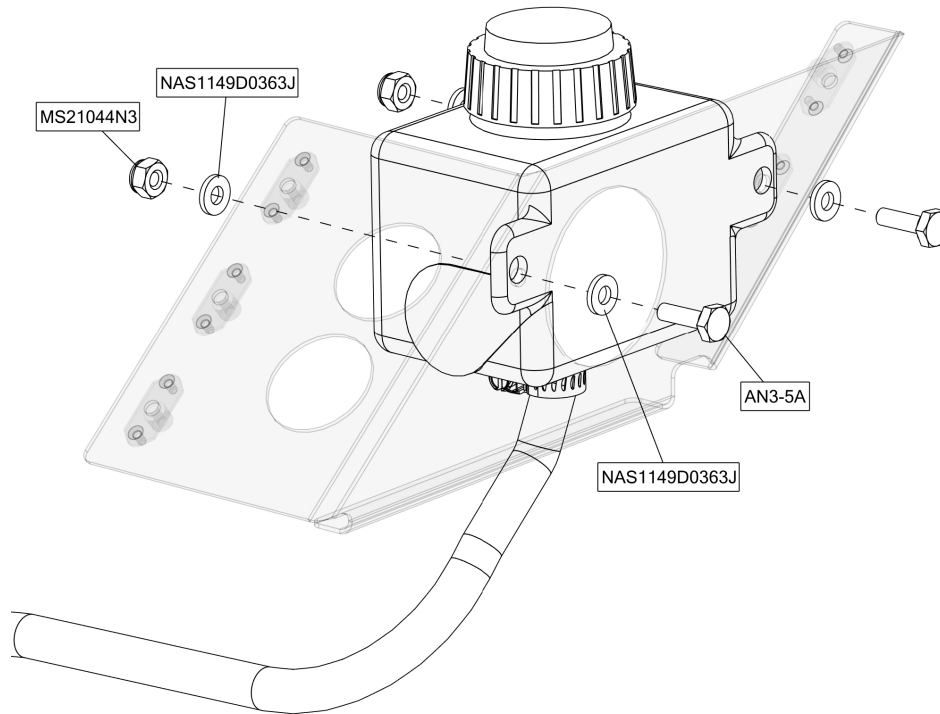

49. Install reservoir bracket with reservoir assembly attached in pylon using (3) AN526C832R8 screws on the outboard skin and (2) AN526C832R6 screws on the inboard skin

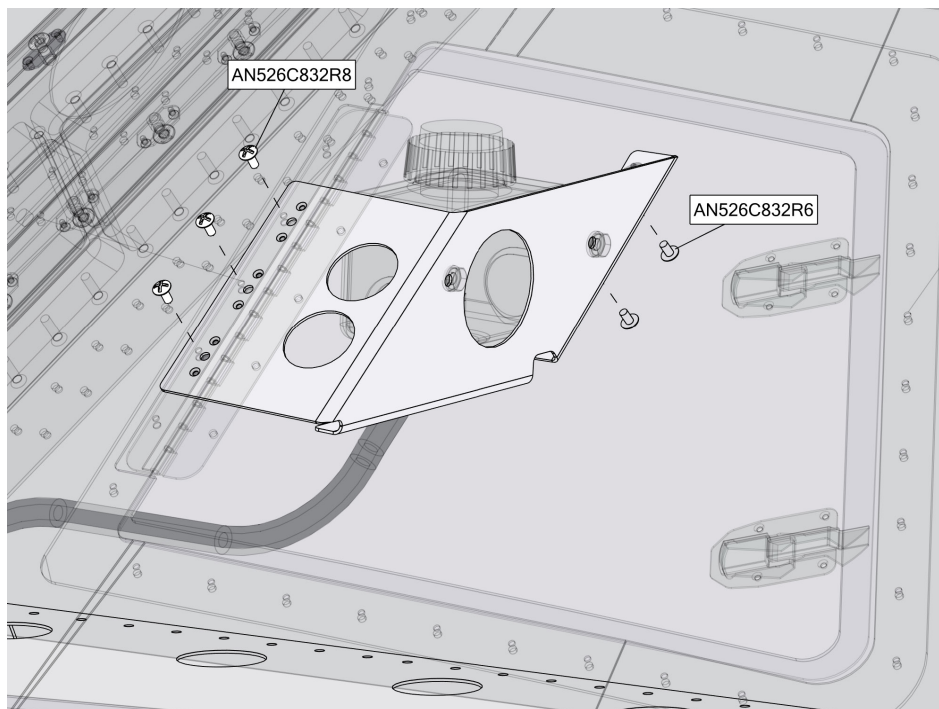

50. Connect the hose to the AN837-4D top deck fitting after removing the AN929-4 cap

Showing instruction for left float installation. Mirror instruction when installing right float components

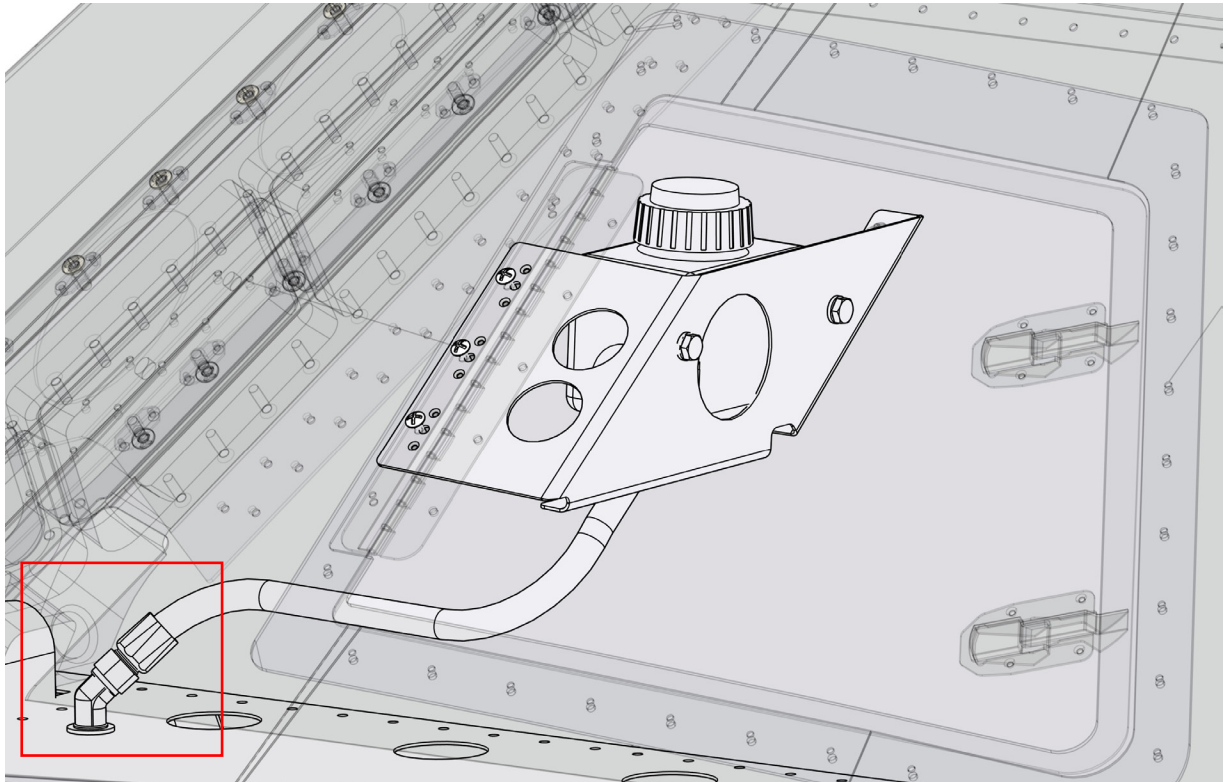

51. Install 1009112 placard (1009113 for right pylon) as shown with the minimum/maximum arrows level to the ground

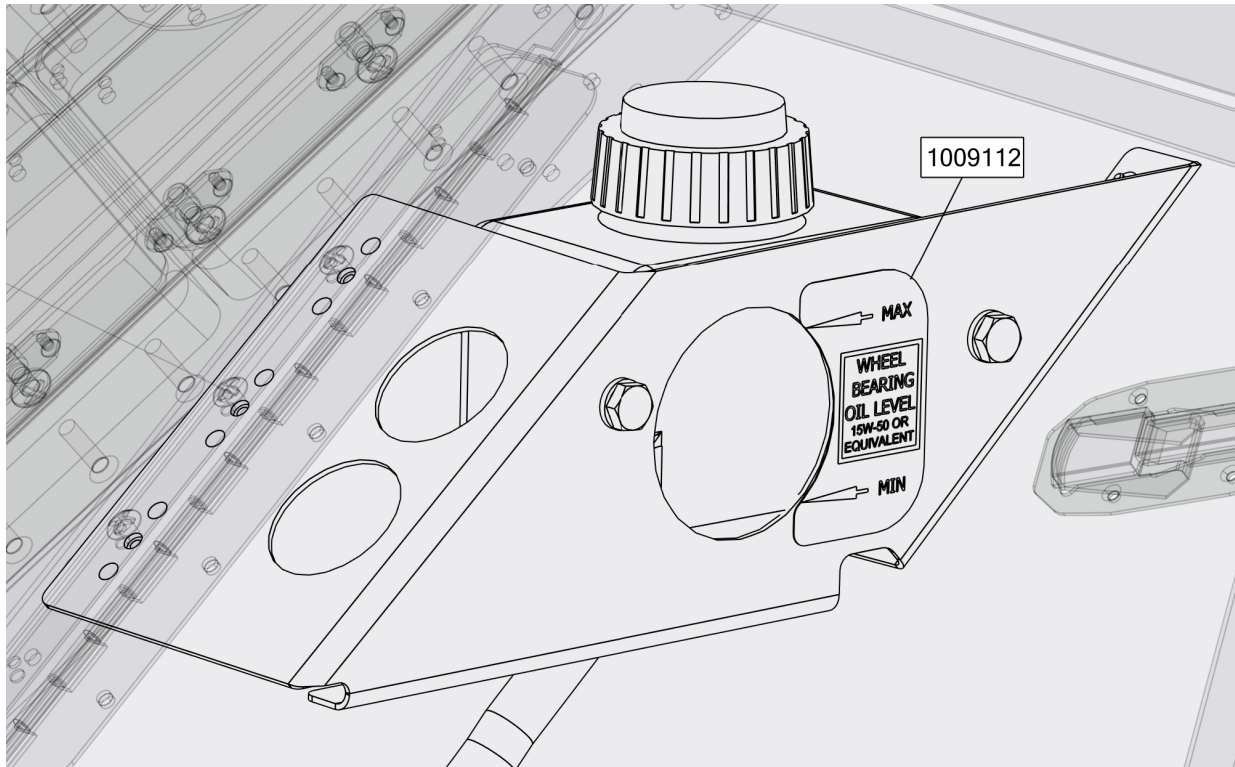

52. Allow 1422 sealant and Loctite to dry per manufacture specifications prior to filling system with oil

53. Fill the oil bath wheel assembly by 1 of the following methods:

**Option 1 - Recommended method, requires pump not provided**

- a. Remove plug on hub cap with drain hole assembly 1008984 and install 1009164 oil bath wheel filler assembly
- b. Using a manual or electric type fluid pump, fill with 15W-50 engine oil or equivalent from the union installed in the hub cap with drain hole assembly until reservoir is full as indicated by placard on reservoir bracket
- c. Remove 1009164 oil bath wheel filler assembly and reinstall plug on hub cap with drain hole assembly 1008984
- d. Ensure the fluid in the reservoir remained in the correct range

**Option 2**

- a. Remove plug on hub cap with drain hole assembly 1008984
- b. Fill reservoir with 15W-50 engine oil or equivalent until oil comes out where axle plug was removed
- c. Reinstall plug on hub cap with drain hole assembly 1008984
- d. Fill the reservoir in the pylon to level indication by placard on reservoir bracket

**NOTE:** Some air will remain in the system and will not affect the functionality of the oil bath wheel system

54. Install .020" safety wire to hub cap with hole assembly

55. Check axle assembly to verify no leaks are present

## RETURNING AIRCRAFT TO SERVICE

56. Release parking brake

57. Bleed brakes

58. Push gear pump circuit breakers in

59. Cycle gear and verify new oil bath wheel hose is clear of obstruction

60. Verify gear is down and lock position

61. Service air in tires to specification provided in service manual

62. Remove jack stands

## WEIGHT AND BALANCE INFORMATION

- Total Weight: 3.6 lbs
- Arm: 216.00 inches

### NOTES:

1. Upon completion of inspection, enter information in Aircraft Logbook for completion of Wipaire Service Letter 171
2. Once service letter is accomplished, please visit [www.wipaire.com](http://www.wipaire.com) and update your aircraft service letter/kit record using the link found on the Customer Support dropdown menu under "Update Service Letter & Kit Compliance Status"