



WIPLINE FLOATS • SKIS • MODIFICATIONS • AIRCRAFT SALES  
AVIONICS • INTERIOR • MAINTENANCE • PAINT REFINISHING



**SERVICE MANUAL & ICA  
FOR THE  
WIPLINE 7000 AMPHIBIAN FLOAT  
ON THE  
QUEST MODEL 100 KODIAK**

**Revision U**

THIS PAGE INTENTIONALLY LEFT BLANK

### LOG OF REVISIONS

Rev	Pages	Description	Date
A	All	Initial Release	6/11/2010
B	All	ECO 22037, See Doc W7001-34-01	8/17/2010
C	All	ECO 22043, See Doc W7001-34-04	9/9/2010
D	All	ECO 22090, See Doc W7001-34-03	10/8/2010
E	All	Update to cover page logo, added instructions and G1000 Land/floatplane software configuration to float removal and Re-install checklists, added 3 blade propeller maintenance section.	11/5/2012
F	All	Added Green Grease as an approved grease.	4/18/2013
G	All	Updated Fig 1-6 for new oleo, updated Fig 4-4A, Fig 4-6 and added 4-4B, changes to MLG rigging procedures, remaining paged repaginated, minor changes to float install and removal instructions.	5/30/2014
H	All	Added shear torque chart, PR 1440 C Sealant and Tef-Gel, removed warranty claim form. Corrected 1200 was 1000, 1400 was 1150 and 1900 was 1300.	5/26/2015
J	All	Added Dow Corning DC4 and Mobil Aviation Grease SHC 100 to approved product list, update exhaust system.	7/29/2015
K	All	Removed "If the floats are installed, remove..." detail in inspection checklist, removed duplicate inspection page, directed chapter 8 to document number 1009486, deleted list of figures and tables.	2/1/2018
L	10	Added reference for Structural Repair Manual part number 1008274 in introduction.	5/1/2019
M	80	Added note for Main Landing Gear Axle Shaft in Maintenance Inspection Checklist.	9/5/2019
N	35, 74-75, 77-81	Added note about STA-Lube. Added STA-Lube to Brake Caliper Grease. Removed Figure 9-1. Added information about corrosion limits. Removed inspection column from Maintenance Checklist.	8/3/2020
P	All	Reformatted manual in new software. Removed Comet Industries GP-730A. Added sections 1.4 through 1.8. Added notes to Figure 9-1 and at the end of Section 9.3.	9/16/2022
R	42	Added note to Section 4.1.	4/6/2023
T	8	Added note to introduction about parts manual.	7/12/2023
U	69-70	Updated note about Bolt Torque and torque limit tables in section 9.0 Service Schedule.	1/2/2024

View most current revision of this ICA at [www.wipaire.com](http://www.wipaire.com).

THIS PAGE INTENTIONALLY LEFT BLANK

## TABLE OF CONTENTS

CHAPTER 1 INTRODUCTION AND GENERAL INFORMATION .....	7
CHAPTER 2 AIRWORTHINESS LIMITATIONS .....	25
CHAPTER 3 NOSE GEAR .....	27
CHAPTER 4 MAIN LANDING GEAR BRAKES & GEAR RETRACTION .....	35
CHAPTER 5 HYDRAULICS .....	53
CHAPTER 6 WATER RUDDER .....	59
CHAPTER 7 ELECTRICAL .....	63
CHAPTER 8 HARTZELL 3 BLADE PROPELLER .....	65
CHAPTER 9 RECOMMENDED PROCESSES, PRODUCTS, & INSPECTION CHECKLISTS .....	67
CHAPTER 10 TROUBLESHOOTING .....	91
CHAPTER 11 INSTALLATION PRINT INFORMATION .....	97
APPENDIX .....	99

## LIST OF FIGURES

FIGURE 1-1 FRONT VIEW .....	9
FIGURE 1-2 TOP & SIDE VIEWS .....	10
FIGURE 1-3 FLOAT TERMINOLOGY .....	11
FIGURE 1-4 MAINTENANCE ACCESS POINTS .....	12
FIGURE 1-5 HYDRAULIC FLUID LEVEL PLACARD .....	14
FIGURE 1-6 FLUID TYPES AND QUANTITIES .....	14
FIGURE 1-7: JACK CRADLE RECOMMENDED MODIFICATION .....	20
FIGURE 1-8: JACKING LOCATION .....	20
FIGURE 1-9: FLOAT SECURING LOCATIONS .....	21
FIGURE 1-10: FLOAT SECURING LOCATIONS OVERVIEW .....	22
FIGURE 3-1 NOSE WHEEL & BOX .....	29
FIGURE 3-2 NOSE WHEEL GREASING .....	31
FIGURE 3-3 NOSE GEAR ITEMS .....	33
FIGURE 4-1 MINIMUM BRAKE LINING THICKNESS .....	37
FIGURE 4-2 MAIN GEAR, LOWER .....	39
FIGURE 4-3 MAIN GEAR GREASING .....	41
FIGURE 4-4A MAIN GEAR ADJ. DOWN .....	42
FIGURE 4-4B MAIN GEAR ADJ. DOWN .....	43
FIGURE 4-5 MAIN GEAR ADJ. UP .....	44
FIGURE 4-6 MAIN GEAR DOWN STOP ADJ. ....	45
FIGURE 4-7 ROTARY ACTUATOR .....	49
FIGURE 4-8 MAIN SHOCK STRUT .....	50
FIGURE 5-1 HYDRAULIC SCHEMATIC .....	55
FIGURE 5-2 HYDRAULIC PLUMBING .....	56
FIGURE 6-1 WATER RUDDER RETRACTION & EMERGENCY GEAR PUMP HANDLES .....	60
FIGURE 6-2 WATER RUDDER CABLE ROUTING .....	61
FIGURE 9-1 FLOAT KIT INSTALLATION ITEMS .....	78
FIGURE A-1 YAGI ANTENNAS INSTALLED .....	101
FIGURE A-2: CUFF REMOVAL .....	101

# CHAPTER 1 INTRODUCTION AND GENERAL INFORMATION

## CONTENTS

1.0 INTRODUCTION .....	8
1.1 GENERAL FLOAT INFORMATION .....	13
1.2 CLEANING .....	17
1.3 CORROSION .....	18
1.4 TOWING .....	19
1.5 HOISTING .....	19
1.6 LEVELING .....	20
1.7 JACKING PROCEDURES .....	20
1.8 JACK REMOVAL .....	22
1.9 MOORING .....	22

## 1.0 INTRODUCTION

This manual is provided for the owners of Wipaire model 7000 Floats as installed on the Quest model 100 Kodiak. It has two main priorities: to inform owners of the level and amount of servicing required to properly maintain their floatplane, and to provide technical data and servicing as specified to maintenance professionals charged with servicing the floats.

When performing standard repairs for Wipline Aluminum Floats, please refer to the “Structural Repair Manual For Wipline Aluminum Floats” part number 1008274. It is available free of charge online at [www.wipaire.com](http://www.wipaire.com).

The service products referred to throughout this manual are described by their trade names and may be purchased from the Wipaire Parts Department.

**Note:** For approved design data parts, reference 7000 float parts manual 1005250 for Quest Kodiak 100.

We, at Wipaire, welcome your purchase and look forward to years of satisfying exchanges with you. Your floats are built with pride and attention to detail, but we want that care to extend beyond your purchase. Our customer service department is available for your questions 24 hours a day, 7 days a week, where ever you are in the world.

### Parts Sales and Technical Support Dept:

Wipaire, Inc.  
1700 Henry Avenue – Fleming Field  
South St. Paul, MN 55075  
Telephone: (651) 306-0459  
Fax: (651) 306-0666  
Website: [www.wipaire.com](http://www.wipaire.com)  
Email: [CustomerService@wipaire.com](mailto:CustomerService@wipaire.com)

In this service manual we have worked hard to include many repair scenarios in addition to the recommended products, practices, and routine maintenance required to keep your floats in working order.

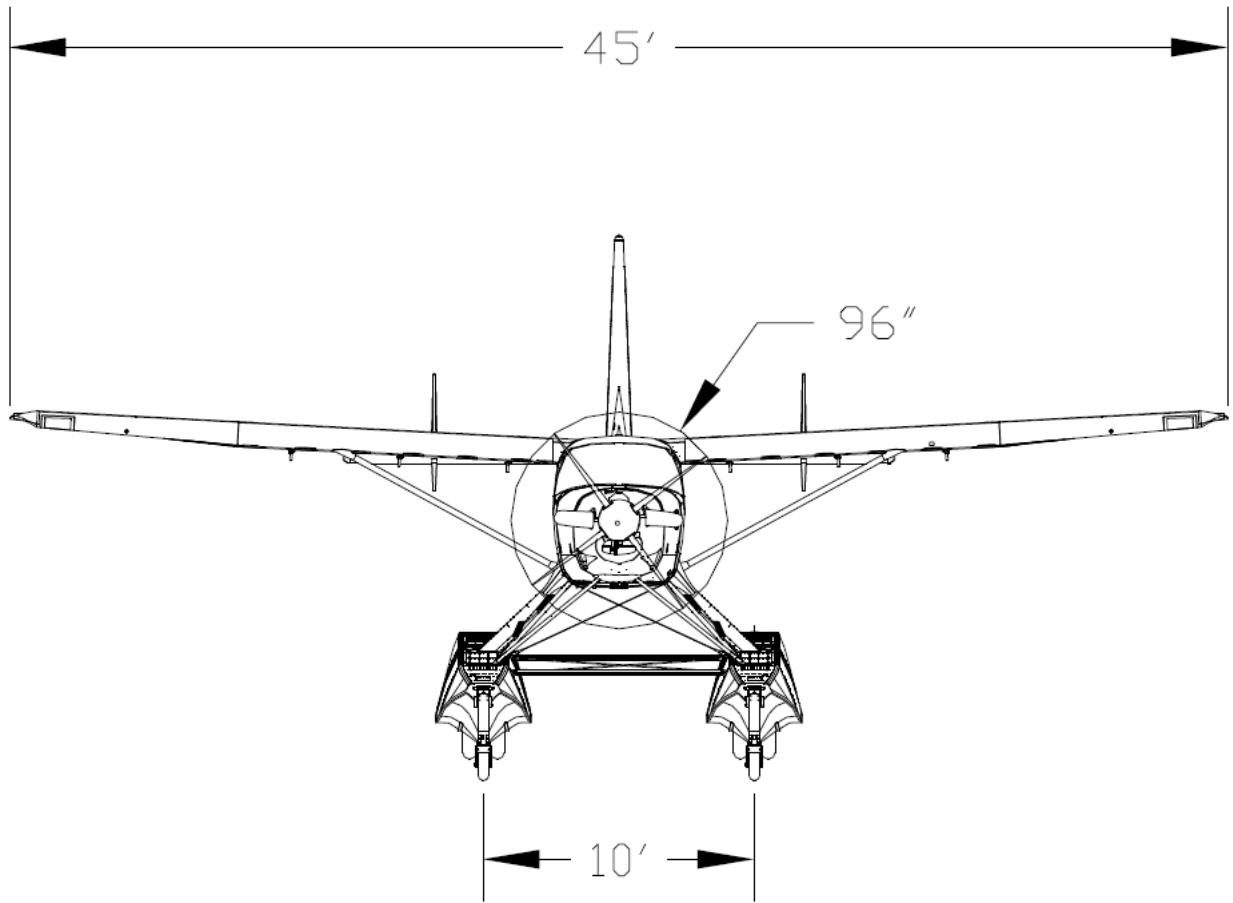
**When a float part is significantly changed or an additional inspection is recommended or required, often a service letter and/or kit is issued. If a warranty is issued, most commonly it is for an 18 month time period, so it is crucial to check for service letters specific to your float model at each periodic inspection to be eligible.**

Service Manuals and the installation prints included are also revised periodically and also to be kept updated.

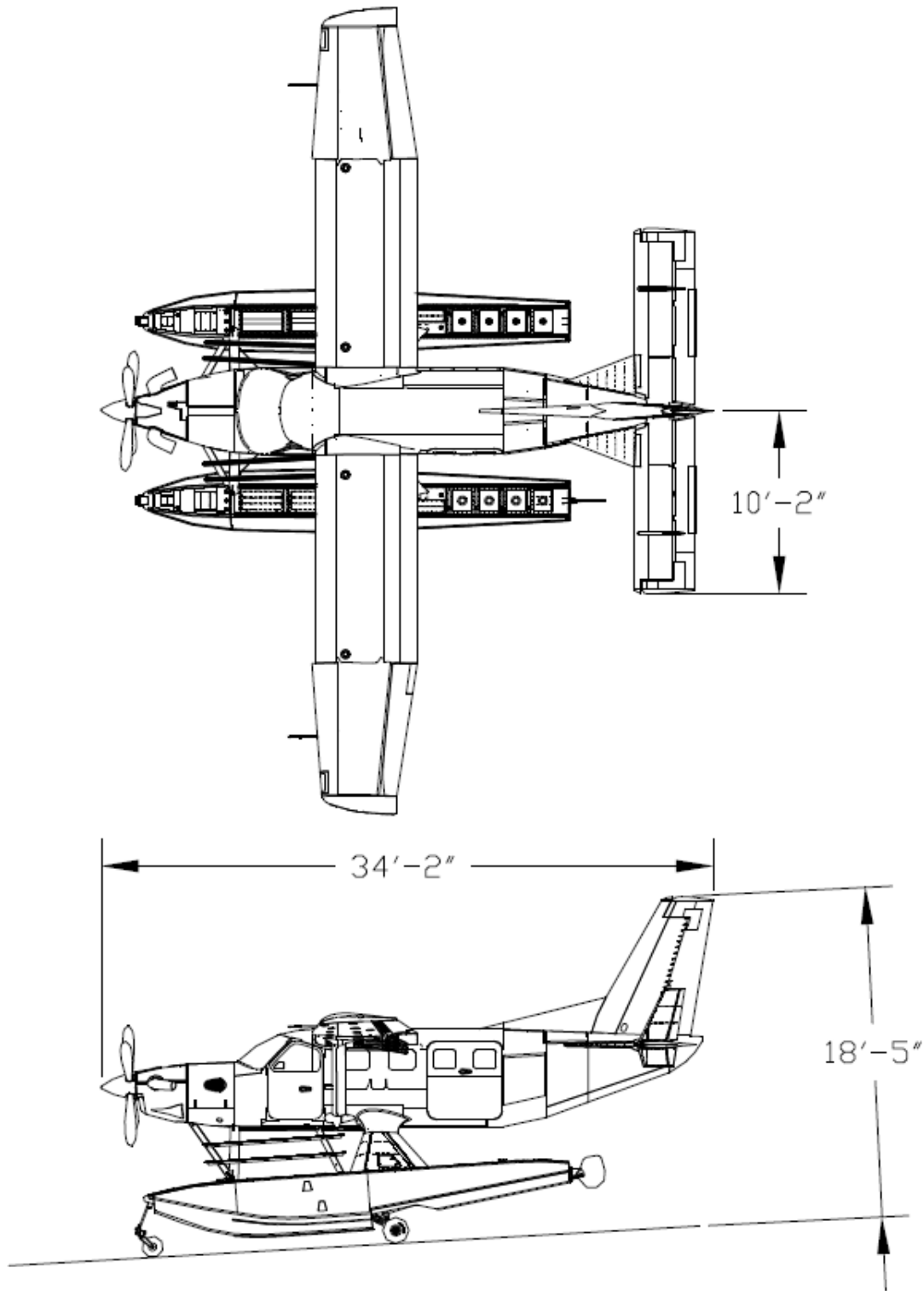
**Service letters, Service Kits and Service Manuals are available on our web site at no charge at [www.wipaire.com](http://www.wipaire.com).**

**NOTE: IT IS CRITICAL TO CHECK FOR MANUAL UPDATES EACH TIME AN INSPECTION IS EXECUTED.**

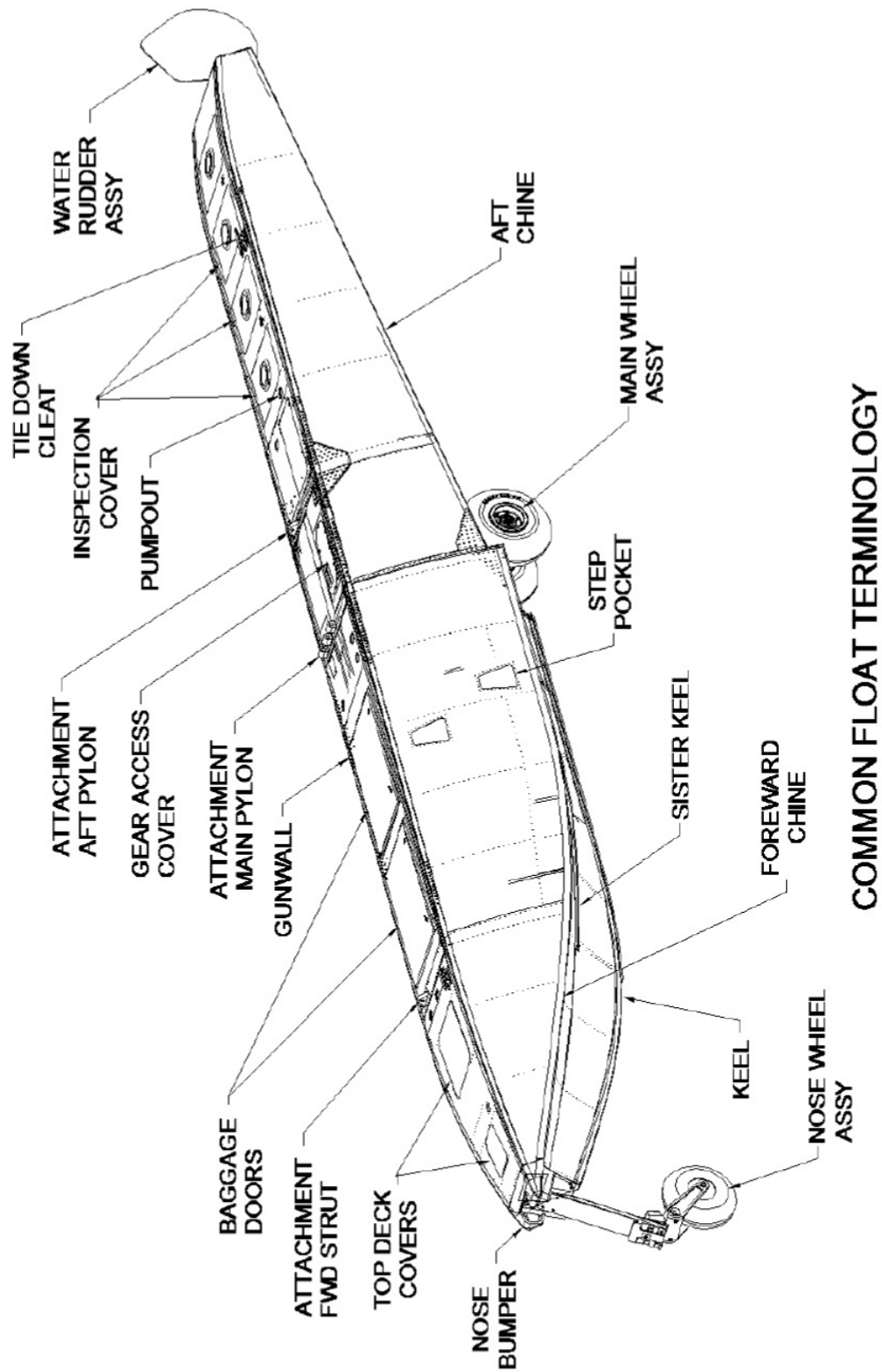




**FIGURE 1-1 FRONT VIEW**

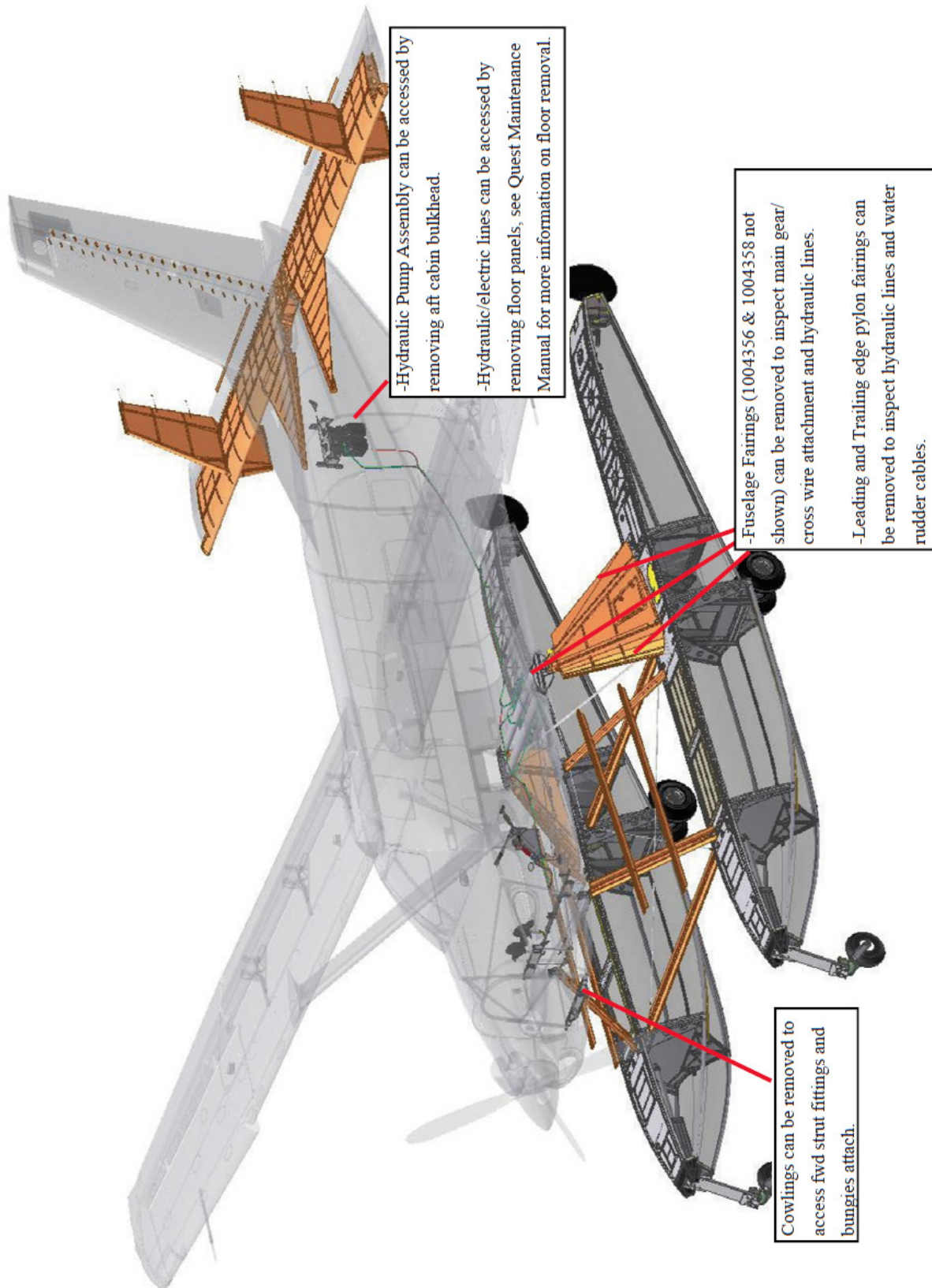


**FIGURE 1-2 TOP & SIDE VIEWS**



**COMMON FLOAT TERMINOLOGY**

**FIGURE 1-3 FLOAT TERMINOLOGY**



**FIGURE 1-4 MAINTENANCE ACCESS POINTS**

## 1.1 GENERAL FLOAT INFORMATION

The model 7000 amphibious float is a clean-sheet, all aluminum structure, designed to be installed on the Quest Kodiak 100. The alloy used throughout is mostly corrosion resistant 6061-T6. Interior parts are cleaned, acid-etched and then primed prior to being riveted for enhanced corrosion resistance. Exterior surfaces are cleaned, alodine is applied as a corrosion resistant barrier, and then primed and custom painted with enamel.

Model 7000 floats contain fifteen (15) water tight compartments per hull. Access to the inside of the floats for cleaning, inspection and repairs is through the covers on the float-deck and the covers inside the wheel well. Figures 1-1 and 1-2 show three view drawings of the Kodiak 100, as installed on Wipline model 7000 amphibious floats.

As a part of the float installation, the following additional changes are made to the landplane:

1. The hydraulic landing gear retraction system components and cockpit controls are added.
2. The landing gear emergency gear operation hand pump and system are added.
3. A water rudder steering system is installed.
4. Auxiliary Vertical Fins are added.
5. Horizontal Strakes are added.
6. Vortex generators are added to the vertical stabilizer.
7. The elevator trim/servo tabs incorporate a 1.5-inch chord extension.

Operational information is detailed in the Airplane Flight Manual Supplement.

Actual displacement for each float in fresh water is:

Amphibian-  
at 100% Buoyancy = 6946 pounds  
at 80% Reserve = 7717 pounds

### LANDING GEAR

The landing gear incorporated within the amphibious floats is a retractable, quadricycle type with two swiveling nose (or bow) wheels and four (4) (two (2) dual sets) of main wheels. Shock absorption is provided by air-oil shock struts on the two main landing gear assemblies and composite flat springs on the nose gear assemblies. Each main wheel is equipped with a hydraulically-actuated disc brake.

Landing gear extension and retraction is accomplished by two (2) electrically-driven hydraulic pumps and four (4) hydraulic actuators (one (1) for each gear).

The hydraulic pumps are located in the aircraft empennage and can be accessed by removing the aft cabin bulkhead. The hydraulic actuators are located adjacent to each gear.

Hydraulic system fluid level should be checked at 25-hour intervals and should be serviced to levels in accordance with the installed placard using MIL-H-5606 (red) hydraulic fluid. The fluid level placard (Figure 1-5) is installed on the forward hydraulic Reservoir.



**FIGURE 1-5 HYDRAULIC FLUID LEVEL PLACARD**

The nose wheels are fully castoring for maneuverability while the airplane is under engine power or being towed. The main landing gear has dual 6:00x6 8-ply tires and the nose gear has a single 5:00x5 10-ply tire. All tires must be approved to TSO C62, type III. Differential use of the main-wheel brakes steers the aircraft on land.

<b>Item</b>	<b>Fluid Type</b>	<b>Qty.</b>
Main Gear Shock Strut	MIL-H-5606	975 +/- 20 mL 33 +/- 0.75oz.
Main Gear Shock Strut	Nitrogen or Air	425 +/- 25 psi
Main Gear Tires	Nitrogen or Air	60 +/- 5 psi
Nose Gear Tires	Nitrogen or Air	60 +/- 5 psi
Hydraulic Pump reservoir	MIL-H-5606	A/R per placard

**FIGURE 1-6 FLUID TYPES AND QUANTITIES**

Grease zerks are provided in many locations that have pivoting joints. Greasing is recommended at 25 hour intervals, or more often depending on operating environment, with HCF Grease or equivalent. See Figure 3-2 for nose gear grease zerk locations. See Figure 4-3 for main gear grease zerk locations.

### **STRUT PACKAGE**

The strut package attaches the floats to the aircraft.

The strut package is comprised of the forward struts, main pylons, rear cross-wires, and front cross wires (or flying wires).

The streamlined struts are made from extruded aluminum alloys. The main pylon is built from machined aluminum trusses, internal ribs, and skinned with aluminum sheet.

### **WATER RUDDERS**

The floats are equipped with water rudders attached at the rear of the float structure. These rudders steer when the floats are in the water.

Rudder controls are integrated into the existing aircraft rudder system and should move in the same direction as the air rudder.

Water rudders are extended and retracted with a handle installed to the right of the pilot seat.



**Water Rudder & Spring**

### **OPTIONAL EXHAUST SYSTEM**

The Kodiak amphibian can be equipped with an optional exhaust system designed to deflect the engine exhaust plume away from the aircraft. This exhaust system is applicable to the floatplane and landplane.

The optional exhaust system consists of a left and right hand waterline cut exhaust stack. The optional heat shield is only installed to assist in cooling of exhaust gases across the left side of the cowling and fuselage.

Operation of the aircraft is unchanged when the optional exhaust system is installed. Specific data related to the performance of the aircraft with this option installed can be found in the Airman's Flight Manual Supplement, Doc. No. W7001-25-01, latest revision.





**Optional Left Exhaust Stack with optional Heat Shield**



**Optional Right Exhaust**



## 1.2 CLEANING

The outside of the float should be kept clean by washing with fresh water and soap. Special care should be taken to remove engine exhaust trails, water-line marks, and barnacle deposits. After salt water operations, washing with fresh water should be done daily with special attention paid to hard to reach places like:

- skin seams
- wheel well areas
- float attach points
- hardware

Alternatively, water taxiing in fresh water at step-speed can help flush the entire system.

The float interior should be flushed out, especially if salt water or polluted water gets inside the compartments. If the floats are being stored inside a building either installed on the aircraft or not, it is strongly recommended to remove the inspection covers so the interior of the floats can dry out.

### **OPERATORS IN SALT WATER ARE STRONGLY CAUTIONED**

RINSING THE AIRCRAFT AND FLOATS WITH FRESH WATER AT THE END OF EACH DAY IS CRITICAL. ADHERING TO THESE CLEANING RECOMMENDATIONS ARE VITAL FOR KEEPING CORROSION TO A MINIMUM. FAILURE TO CLEAN THOROUGHLY CAN SEVERELY SHORTEN THE LIFE OF THE FLOATS.

SALT WATER, POLLUTED WATER, AND THEIR ENVIRONMENTS ARE STRONGLY AND DIRECTLY LINKED TO CORROSION AND MUST BE HANDLED PROACTIVELY.



**Even without direct contact with saltwater, this hydraulic pump in the aircraft fuselage has severely corroded due to being in a saltwater environment without being kept clean.**

## 1.3 CORROSION

Reference the Wipaire Structural Repair Manual (SRM) for allowable corrosion/material loss limits. Corrosion is the process by which metals are turned into oxides. It is a natural and ultimately unavoidable chemical reaction that is accelerated by dissimilar metals in contact with each other, and enclosed spaces and contaminants like dirt and exhaust deposits that hold moisture against the metal. If that moisture is salt water or fresh water that is polluted, it conducts the electrolytes better and the process of corroding is faster.

Most aircraft and most floats are made out of aluminum due to its strength to weight ratio, and its ability to withstand fatigue and remain field repairable.

Steel is used for strength in hardware and landing gear parts, and these are often areas where these dissimilar metals cause corrosion.

Areas where moisture and dirt mix and stay wet against metal are common sites of oxidation. Float strut attach points, water rudders, and skin joints are examples of areas where this occurs.

### CORROSION HOT SPOTS

- DISSIMILAR METAL CONTACT LIKE LANDING GEAR, FLOAT ATTACH POINTS AND OTHERS.
- ENCLOSED SPACES THAT STAY MOIST LIKE LANDING GEAR FLOAT INTERIORS, SKIN LAP-JOINTS, AND OTHERS.
- CONTAMINATES ON THE METAL LIKE DIRT, SALT, ENGINE EXHAUST AND OLD OR OTHERWISE COMPRISED GREASE.



Cladding, plating, anodizing, painting, greasing and waxing are all processes used to help protect metal from corrosion; Wipaire uses all these techniques during manufacture. But due to the rugged way our floats are used and the environment, these surface sealers become abraded or wear away, leaving the metal exposed.

Removal of corrosion is detailed more fully in Chapter 8, but there are a few things an owner can do to stop the spread of corrosion and minimize the damage. Aside from the already detailed cleaning and inspection procedures, an anti-corrosion spray like Corrosion X, or its equivalent, should be used liberally. Because it has the ability to displace moisture and contaminants, it can be used when the floats are still wet or when they are dry.

Periodically, hardware should be covered with waterproof grease. Especially in a salt water environment, bolts should be removed at least once a year and grease applied to the shafts, bolt/screw heads, and nuts.

## 1.4 TOWING

When towing the amphibian aircraft, 2 lugs are provided on the lower forward side of the nose spring.

On land, a rigid "V" frame can be fabricated to attach to these lugs for towing the aircraft with a tractor. Lake & Air Training and Pilot Shop has this tow bar available for purchase.



On water, a rope bridle arrangement can be used to tow the aircraft from the lugs described above.

## 1.5 HOISTING

Hoisting the aircraft can be performed using a lifting rig that attaches to the aircraft with lifting rings that are installed at the wing attach points. If the lifting rings are not installed, reference applicable aircraft maintenance/service manual for additional hoisting specifications. Lake & Air Training and Pilot Shop has this hoisting rig available for purchase. Contact Wipaire Customer Service for additional guidance in removal or installation of floats.

### **CAUTION!**

**Make sure nothing is under or above the airplane or floats when hoisting the aircraft**

1. Raise aircraft high enough to place float cradle under floats as shown in Figure 1-10.
2. Lower aircraft onto float cradle as shown in Figure 1-10.
3. Place fore and aft supports as shown in Figure 1-9 and Figure 1-10.

## 1.6 LEVELING

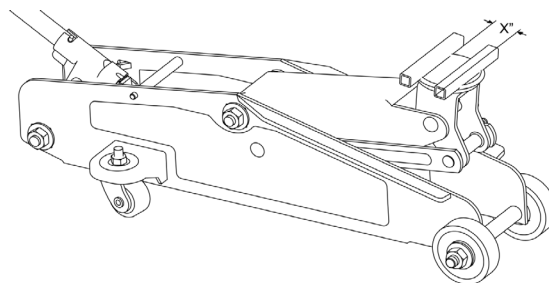
See applicable aircraft maintenance/service manual.

## 1.7 JACKING PROCEDURES

### CAUTION!

**Make sure nothing is under or above the airplane or floats when jacking the aircraft.**

1. Turn off fuel.
2. Place weighted bags above the nose gear (approximately 100 lbs. on each float to start, more may be added as needed).
3. Position 1 person at each fore and aft of each float, and 3 people at the jacking location of one float.
4. Modify jack saddle of a 3 ton minimum jack by welding as shown in Figure 1-7.



(X = WIDTH OF CRADLE)

**FIGURE 1-7: JACK CRADLE RECOMMENDED MODIFICATION**

**NOTE:** This is not required and Wipaire does not have the parts for modification. It is recommended a similar modification be performed to the jack saddle to prevent the slippage of the cradle.

1. Center cradle on saddle and position so cradle is as far aft on the main keel as possible without interfering with main gear as it decompresses as shown in Figure 1-8.

**NOTE:** If desired to prevent possible cosmetic damage to float, use material to separate cradle and float.



**FIGURE 1-8: JACKING LOCATION**

SERVICE MANUAL & ICA  
WIPLINE 7000 FLOATS

1. Jack one side at a time, taking care to check the balance of the aircraft and adding more weight to the front if needed.
2. Two people, both outboard, lift the fore and aft cradle stands up to the cradle as a 3rd person release the pressure slowly, allowing the cradle and stands to gently contact the ground.
3. Repeat previous procedure to the other float.

**NOTE:** A smaller jack may be needed to slightly lift the float into a high enough position for the main jack.

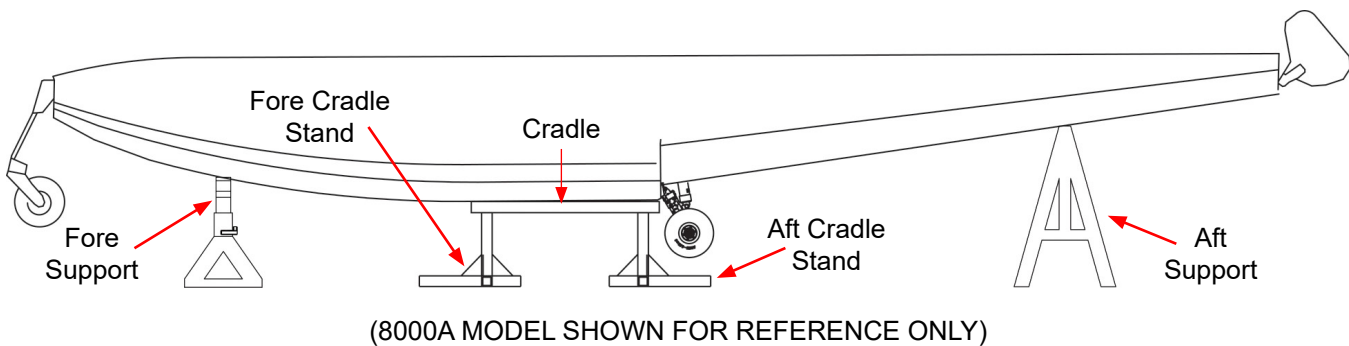
4. Secure floats with fore and aft supports as shown in Figure 1-9 and Figure 1-10.



**FIGURE 1-9: FLOAT SECURING LOCATIONS**







**FIGURE 1-10: FLOAT SECURING LOCATIONS OVERVIEW**

## 1.8 JACK REMOVAL

**Make sure nothing is under or above the airplane or floats when removing the jacks from the aircraft**

1. Turn off fuel.
2. Verify landing gear is in the down and locked position.
3. Verify weighted bags are still located above the nose gear.
4. Position 1 person at each fore and aft of each float, and 1 person at the jacking location of one float.
5. Remove all fore and aft supports as shown in Figure 1-9 and Figure 1-10.
6. Using modified jack saddle as shown in Figure 1-7, center jack saddle in center of cradle on 1 of the floats,
7. Lift aircraft to clear fore and aft cradle stands and remove fore and aft cradle stands of lifted float.
8. Slowly lower float to the ground, remove jack from under float, and remove cradle from jack saddle.
9. Repeat previous procedure to the other float.
10. Remove weighted bags from floats.

## 1.9 MOORING

For land operations, the aircraft is equipped with three fixed mooring points. Two are located on the outboard edge of the wing struts and the other is located on the underside of the tail section of the aircraft.

Mooring Procedure on Land:

1. Position the aircraft near mooring location and it point into the wind.
2. Set the parking brake and/or chock the main wheels.
3. Install the aircraft control column lock.
4. Install the flight control gust lock.
5. Tie down the aircraft to anchor points on the ground.
6. Install provided engine inlet covers, pitot tube covers, and propeller anchor assembly.
7. Attach a static ground cable to one of the aircraft tie-down eyelets and the ground anchor point.

For water operations, the floats are equipped with two deck cleats on each float, one forward near the pilot/copilot doors, and one aft near the cargo door.

Mooring Procedure on Water at Dock:

1. Position the aircraft near the dock and point into the wind as much as able.
2. Install the control column lock.
3. Install the flight control gust lock.
4. Tie down using both deck cleats to secure aircraft to dock and keep it from moving if wind direction shifts.

Mooring Procedure on Water at Buoy:

1. Position the aircraft near buoy.
2. Install the control column lock.
3. Install the flight control gust lock.
4. Tie to buoy using one deck cleat and leave sufficient slack in the rope so that the aircraft can move as the wind direction shifts without causing damage to aircraft.

THIS PAGE INTENTIONALLY LEFT BLANK



## CHAPTER 2 AIRWORTHINESS LIMITATIONS


### CONTENTS

2.1 AIRWORTHINESS LIMITATIONS .....	26
-------------------------------------	----

## 2.1 AIRWORTHINESS LIMITATIONS

This Airworthiness Limitations section is FAA approved and specifies maintenance required under paragraphs 43.16 and 91.403(c) of the Federal Aviation Regulations unless an alternative program has been FAA approved.

The aircraft Airworthiness Limitations are unchanged as a result of installation of the Amphibious Floats and the associated systems addressed by this STC.

FAA APPROVED   
DATE 6/11/10

## CHAPTER 3 NOSE GEAR

### CONTENTS

3.0 NOSE GEAR .....	28
3.1 ADJUSTMENT/TEST NOSE GEAR .....	30
3.2 NOSE GEAR BASIC SERVICING .....	30
3.3 NOSE GEAR DISASSEMBLY .....	32
3.4 NOSE GEAR ASSEMBLY .....	32

## 3.0 NOSE GEAR

The nose gear consists of composite fiberglass beams that are attached at the bottom to blocks that caster. Inside the block is a casting pin that is set into the machined fork assembly. The casting pin allows the nose wheel to pivot in a complete circle. The geometry is such that no shimmy dampers are necessary.

The nose gear has an over-center down lock. Retraction occurs when pressure is applied to the forward face of the actuator piston and the carriage is drawn along the tracks in the nose box. Gear position light proximity switches are closed when the piston containing the magnetic material has reached either end of its travel. Refer to Figure 3-1 for visual reference.

The nose gear has single 5:00 x 5 10-ply tire. All tires must be approved to TSO C62, type III.

### NOSE WHEEL AND TIRE REMOVAL

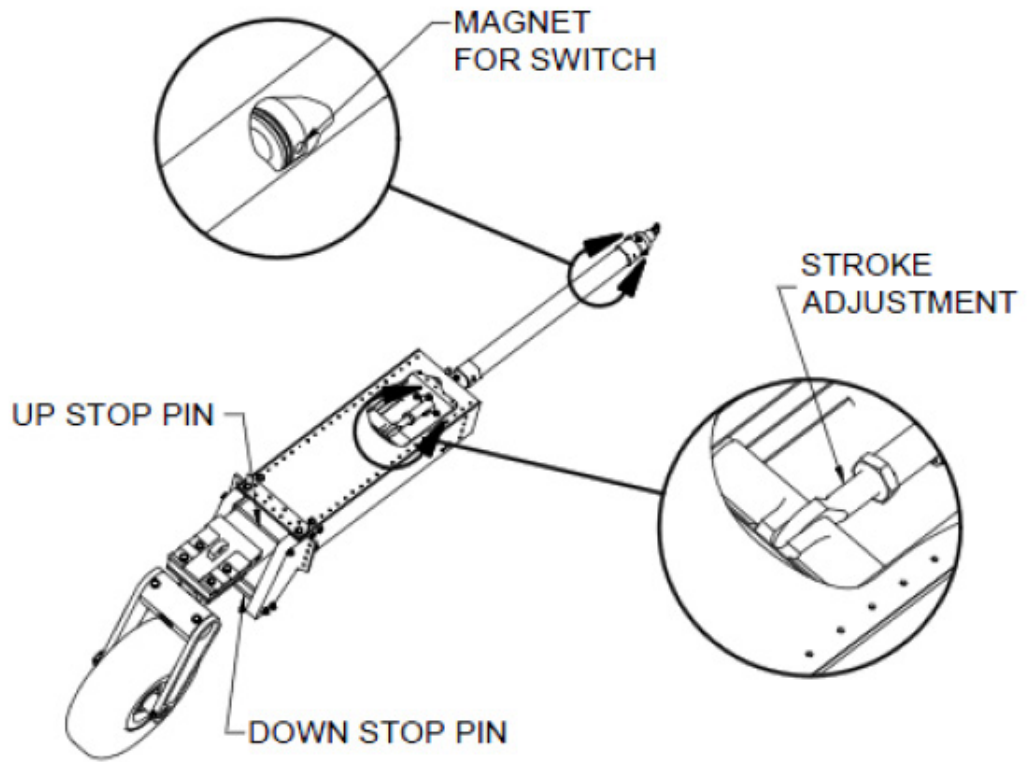
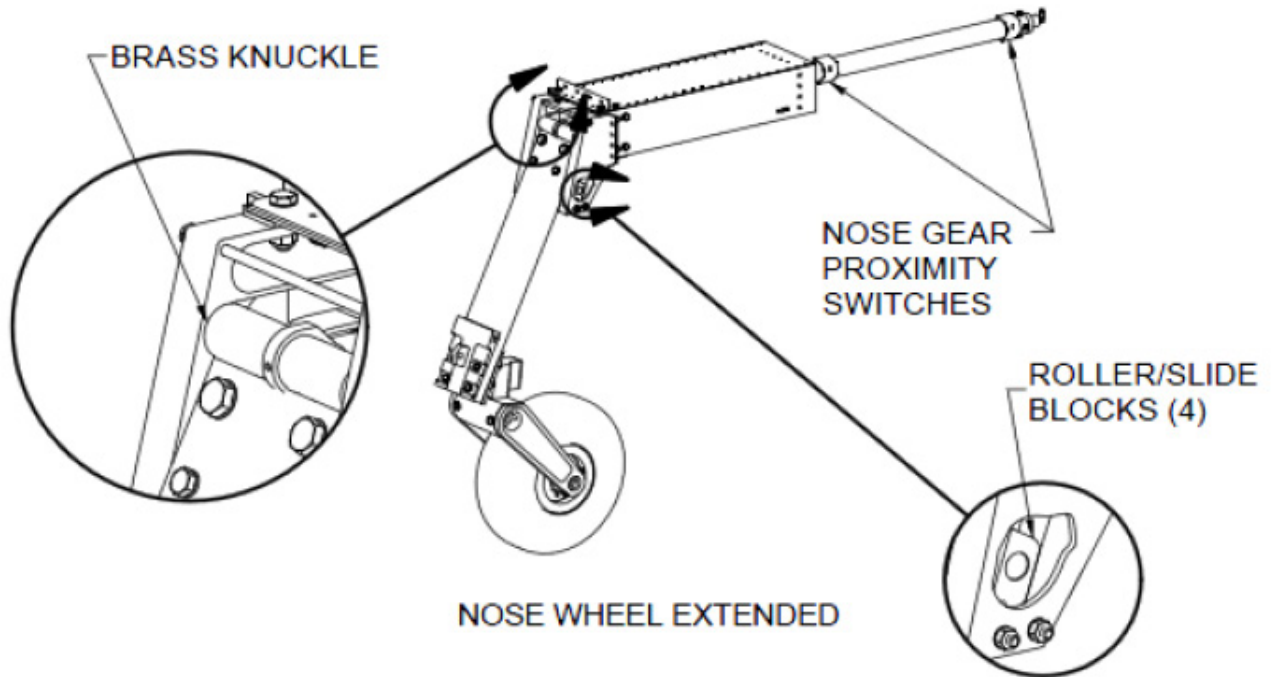
#### To remove each nose wheel:

1. Cut cotter pin and remove axle nut
2. Remove the AN4 bolt securing the opposite side of the axle
3. Pull/Push the axle through the side plate (either direction) taking care to set spacers aside as they are removed
4. Wheel will drop out between side plates once axle has been moved a sufficient distance

#### Each nose wheel is a split-type rim. To remove the tire:

1. Remove air from tire
2. Remove 6 bolts that hold wheel together
3. Split rim and remove tire and tube

Nose tires should be replaced when the tread is worn through in any area. Reinstallation is the reverse of removal.



**FIGURE 3-1 NOSE WHEEL & BOX**

### 3.1 ADJUSTMENT/TEST NOSE GEAR

Refer to Figure 3-1 for visual reference. Adjustment of actuator stroke is provided at the ends of the piston rods. The length of the nose gear rod is adjusted such that the over-center knuckle (brass) rollers just bottom out on the down side and the piston just bottoms out on the mounting flange. The up stops nests in the up-stop pin.

Nose gear proximity switches are located on clips that are mounted on the outer cylinder body, one on each end. The most forward switch is for the gear down lights and most aft is for the gear up position lights. Set the proximity switch mounting clip along outer cylinder body to a position such that the light goes out when the over-center track is about ¼ inch from bottomed position while traveling in the up direction. Lights should come on about 1/8 inch from the bottomed position while traveling in the down direction.

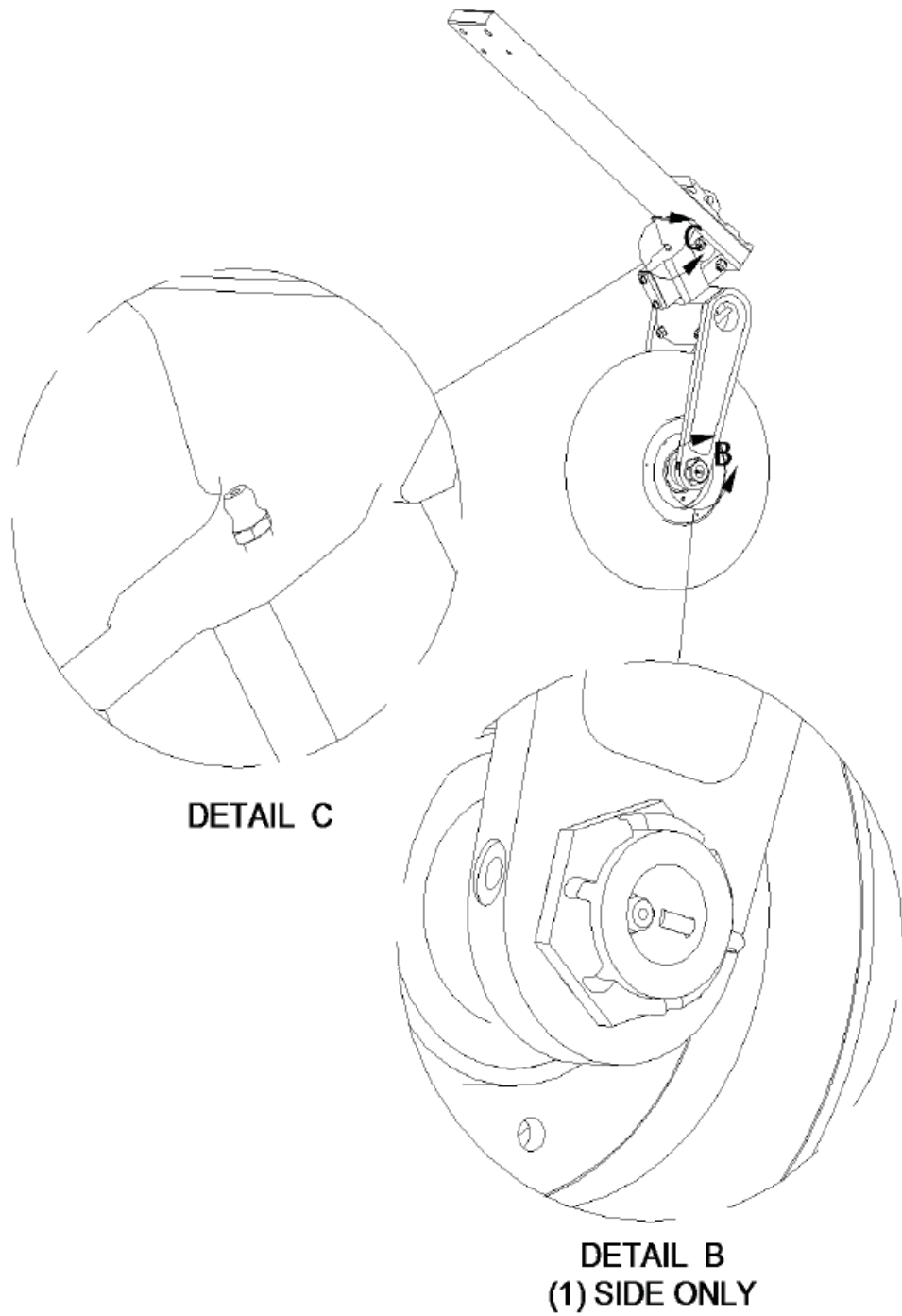
The cylinder piston has a magnet that will activate the proximity switches.

### 3.2 NOSE GEAR BASIC SERVICING

Refer to Figure 3-2 for visual reference. The nose gear pivot assembly should be cleaned and inspected every 25 hours or more frequently whenever in water for extended period of time, especially saltwater. Tracks and blocks should be cleaned and left dry or alternately cleaned and wiped with a rag with dry silicone spray on it.

The nose wheels contain grease nipples for the wheel bearings. They should be greased every 25 hours.

Nose tires are standard 5:00 x 5, 10-ply, inflated to 60 +/- 5 psi. All tires must be approved to TSO C62, type III.



**FIGURE 3-2 NOSE WHEEL GREASING**

### 3.3 NOSE GEAR DISASSEMBLY

(In float or removed from float) Items refer to areas on Figure 3-3

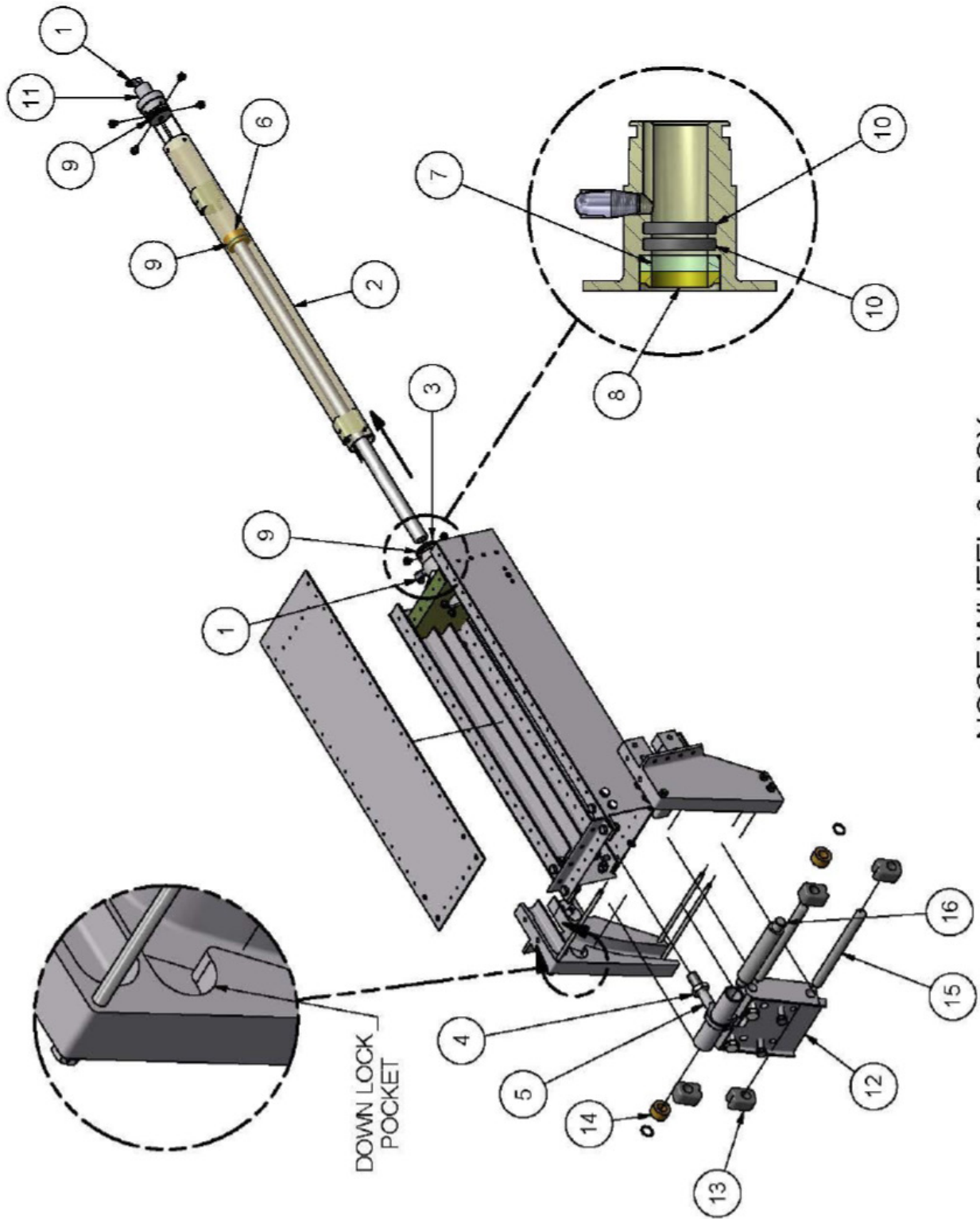
1. Disconnect hydraulic lines, Item 1.
2. Remove 4, NAS1103-2 bolts and washers attaching the Nose Ram, Item 2, to the Flange Assembly, Item 3, and slide the Nose Ram off of the Flange Assembly.
3. Inspect interior bore of the Nose Ram for corrosion and pitting.
4. Loosen AN316-10R Jam Nut, Item 4, on Nose Ram Rod End, Item 5.
5. Using a strap wrench or other suitable, non-marring tool, unthread the Ram, Item 6, from the Nose Ram Rod End. Do not attempt to remove the ram piston top (brass) from the ram shaft (stainless steel). They are assembled as a unit and permanently secured.
6. Remove Ram Assembly, Item 3, if desired to replace the T-seals, Item 10, felt wiper, Item 7, and plastic wiper, Item 8.
7. Replace T-seals on the Nose Ram, Item 9, and Ram Assembly, Item 3, if necessary. The T-Seal in the Cylinder End-Cap, Item 11, can be replaced by removing the NAS1103-2 bolts and removing the cap from the Cylinder.
8. Slide the Trolley, Item 12, out bottom of nose gear track.
9. If worn or damaged, replace the 4 Slide Blocks, Item 13, and the 2 Track Rollers, Item 14.
10. Grease the 2 axles, Items 15 & 16, when reassembling.

### 3.4 NOSE GEAR ASSEMBLY

Items refer to areas on Figure 3-3

1. Insert the Ram Assembly, Item 6, into the Flange Assembly, Item 3, if removed during disassembly.
2. Slide the Trolley, Item 12, with installed blocks and rollers into nose box track from bottom.
3. Pull forward on the Link, still attached to the Rod End, Item 5, to place the rollers, Item 14, into the down lock pocket on the nose box track.
4. Thread the Ram Assembly, Item 6, onto the Rod End, Item 5, until the ram piston contacts the Flange Assembly, Item 7, while at the same time the rollers are seated in the down lock pocket. Both the piston and the rollers need to bottom out against their respective mating parts at the same time.
5. Tighten the AN316-10R jam nut against the rod end.
6. Install the Nose Ram, Item 2, onto the Flange Assembly, Item 3, being careful not to nick T-Seals on bolt holes. Fasten with NAS1103-2 bolts and necessary washers.
7. Oil felt wiper through oil cup on the Flange Assembly, Item 3.
8. Connect hydraulic lines to cylinder and cycle gear to fill cylinder with fluid.
9. Service hydraulic system with Mil-H-5606 if necessary.





**FIGURE 3-3 NOSE GEAR ITEMS**

THIS PAGE INTENTIONALLY LEFT BLANK

## CHAPTER 4 MAIN LANDING GEAR BRAKES & GEAR RETRACTION

### CONTENTS

4.0 GENERAL.....	36
4.1 MAIN GEAR RETRACTION DESCRIPTION.....	40
4.2 MAIN GEAR ASSEMBLY SETUP AND ADJUSTMENT .....	46
4.3 ADJUSTING THE GEAR UP POSITION.....	48
4.4 ADJUST MAIN GEAR UP AND DOWN POSITION SWITCHES.....	48
4.5 EMERGENCY GEAR OPERATION .....	51

## 4.0 GENERAL

The main landing gear incorporated within the amphibious floats are retractable, quadricycle type with four main wheels in a dual tire formation. Air-oil shock struts on the two main landing gear assemblies provide shock absorption.

The main landing gear has dual 6:00 x 6 8-ply tires. All tires must be approved to TSO C62, type III. The gear system is hydraulically actuated and driven by two hydraulic pumps. Brakes are hydraulic and there is a caliper on each main wheel.

### BRAKE REMOVAL & INSPECTION

Each main wheel has a dedicated brake caliper. To remove the brake caliper:

1. Remove two mounting bolts on each caliper
2. Compress the caliper piston using a c-clamp
3. Slide caliper off of the brake disc
4. At brake installation, apply STA-Lube synthetic brake and caliper grease or equivalent to brake caliper pins.

Brake pads should be replaced when the minimum section thickness is less than 0.100", see Figure 4-1.

Generally, the brake discs should be checked for wear, grooves, deep scratches, and excessive pitting. Pitting deeper than 0.015" or thickness below 0.327" is cause for replacement.

### MAIN WHEEL AND TIRE REMOVAL

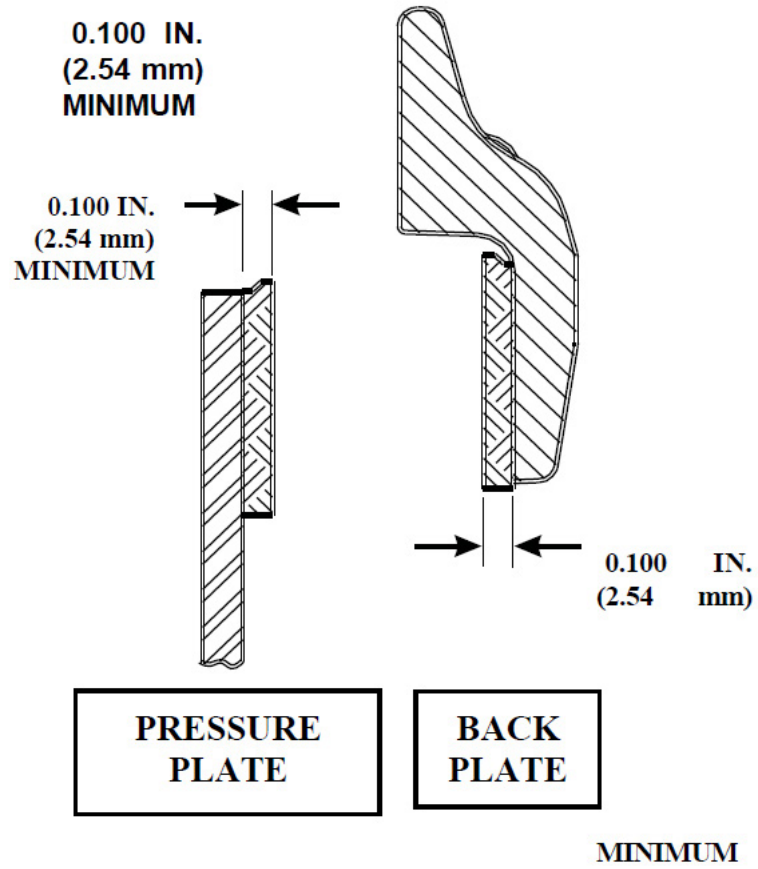
To remove each main wheel:

1. Remove brake caliper
2. Cut cotter pin and remove axle nut
3. Pull wheel off of axle.

Each main wheel is a split-type rim. To remove the tire:

1. Remove air from tire
2. Remove 3 bolts that hold wheel together
3. Split rim and remove tire and tube

Main gear tires should be replaced when the tread is worn through in any area. Reinstallation is the reverse of removal for tires, wheels, and brakes.



**FIGURE 4-1 MINIMUM BRAKE LINING THICKNESS**

### **MAIN GEAR/WHEEL ALIGNMENT**

There is no way to adjust the alignment within each main gear wheel set. If the tires are showing signs of abnormal/asymmetric wear, some component has likely been worn/bent.

Starting with the axle, examine each main gear component and mounting point for signs of damage/deformation. Replace damaged components once found.

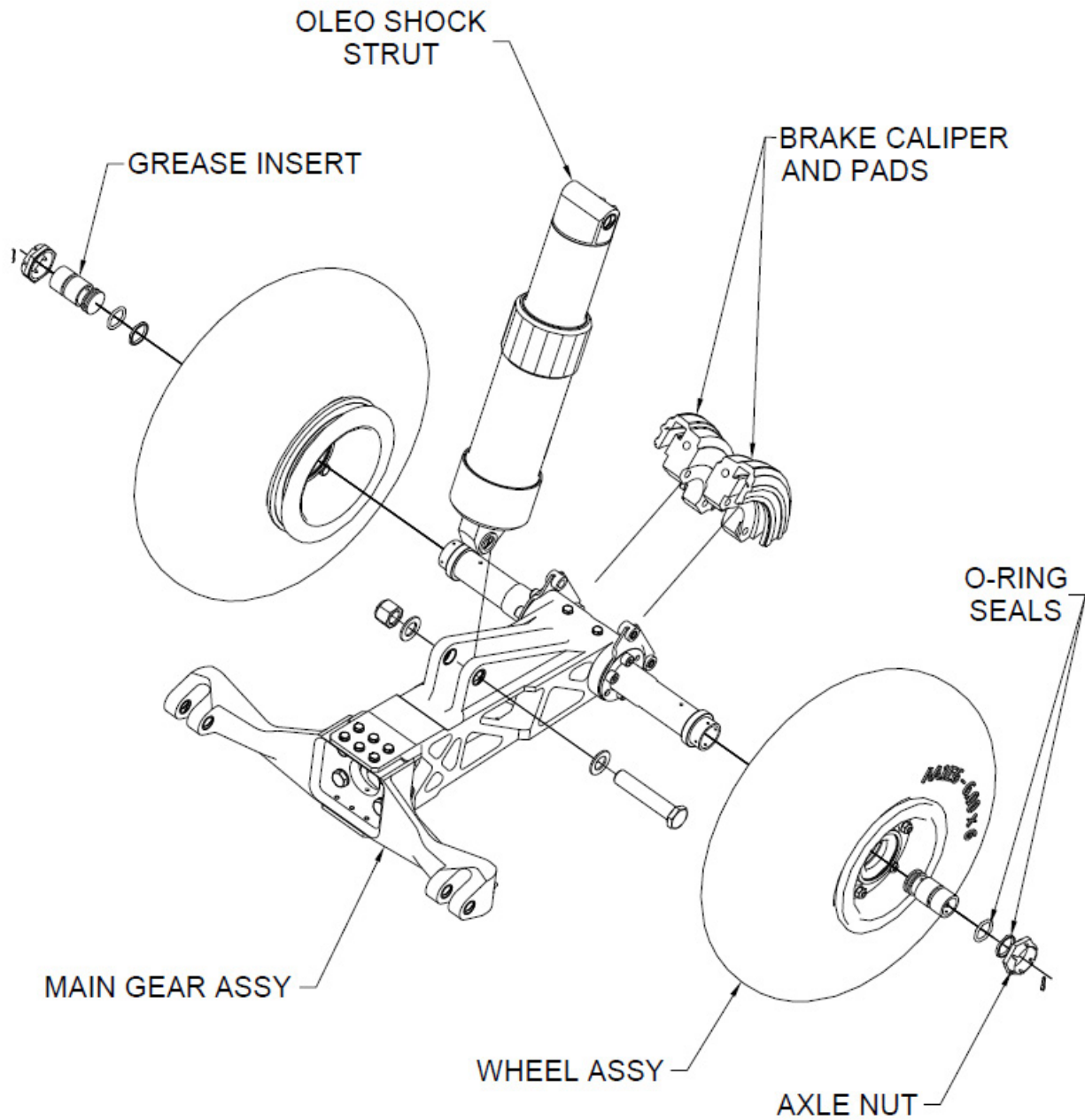
If no gear/bulkhead components are found to be damaged, use the following procedure to align left and right floats:

1. Move aircraft to level surface
2. Check float alignment by measuring boxing wire lengths (horizontal cross wires between spreader bars)
3. If not equal, loosen both wires until there is no tension
4. Start with "long" wire and tighten until both wires measure the same length
5. Tighten the remaining loose wire until snug

### **BLEEDING BRAKE SYSTEM**

Whenever the hydraulic brake lines are disconnected and reattached the brake system should be bled. To bleed the brake system:

1. Check that all lines are properly attached between the brake calipers and brake master cylinders.
2. Check brake fluid reservoir level and fill to MAX line (located on the pilot side of the engine compartment mounted to the firewall).
3. Depress brakes using pilot pedals, brakes will likely be "spongy" and need significant travel to build braking force.
4. Loosen hydraulic fitting at one brake caliper just enough to let fluid and air seep out when brakes are actuated.
5. While one person actuates the brakes, a second person should watch the brake caliper with the loose fitting.
6. If air is in the system, actuating the brakes will cause bubbles in the fluid coming out of the loosened brake caliper fitting.
7. Actuate the brakes through full travel several times until all the bubbles have been released and fluid is being expelled at the loose caliper without signs of air.
8. Tighten the loose caliper fitting.
9. Check fluid level in brake fluid reservoir and refill to MAX line as necessary.
10. Repeat procedure at each caliper.
11. When complete, brakes should not feel "soft" or "spongy" when actuated.



**FIGURE 4-2 MAIN GEAR, LOWER**

## 4.1 MAIN GEAR RETRACTION DESCRIPTION

Refer to Figures 4-1, 4-2, 4-3, 4-4A, 4-4B, 4-5 and 4-6 for visual reference.

Retraction and extension of the main gear is accomplished with a hydraulic rack and pinion type actuator. The actuator consists of two opposing pistons connected by a geared rack, with a rotating pinion gear in the middle.

Hydraulic fluid is transferred from one piston to the other using an electrically reversible hydraulic pump located in the empennage of the aircraft. The differential pressure build up causes the piston to move, pushing the rack and rotating the pinion gear and its attached drive shaft.

Attached to each end of the drive shaft are actuating arms that drive separate rod linkages with adjustable rod ends. The drive shaft and actuating arms have a keyway to prevent slippage on the rotating drive shaft. The rod linkages push and pull on the Main Gear Top Arm Assembly causing it to pivot around a fixed point. Also attached to the actuators drive shaft is a visual gear position indicator.

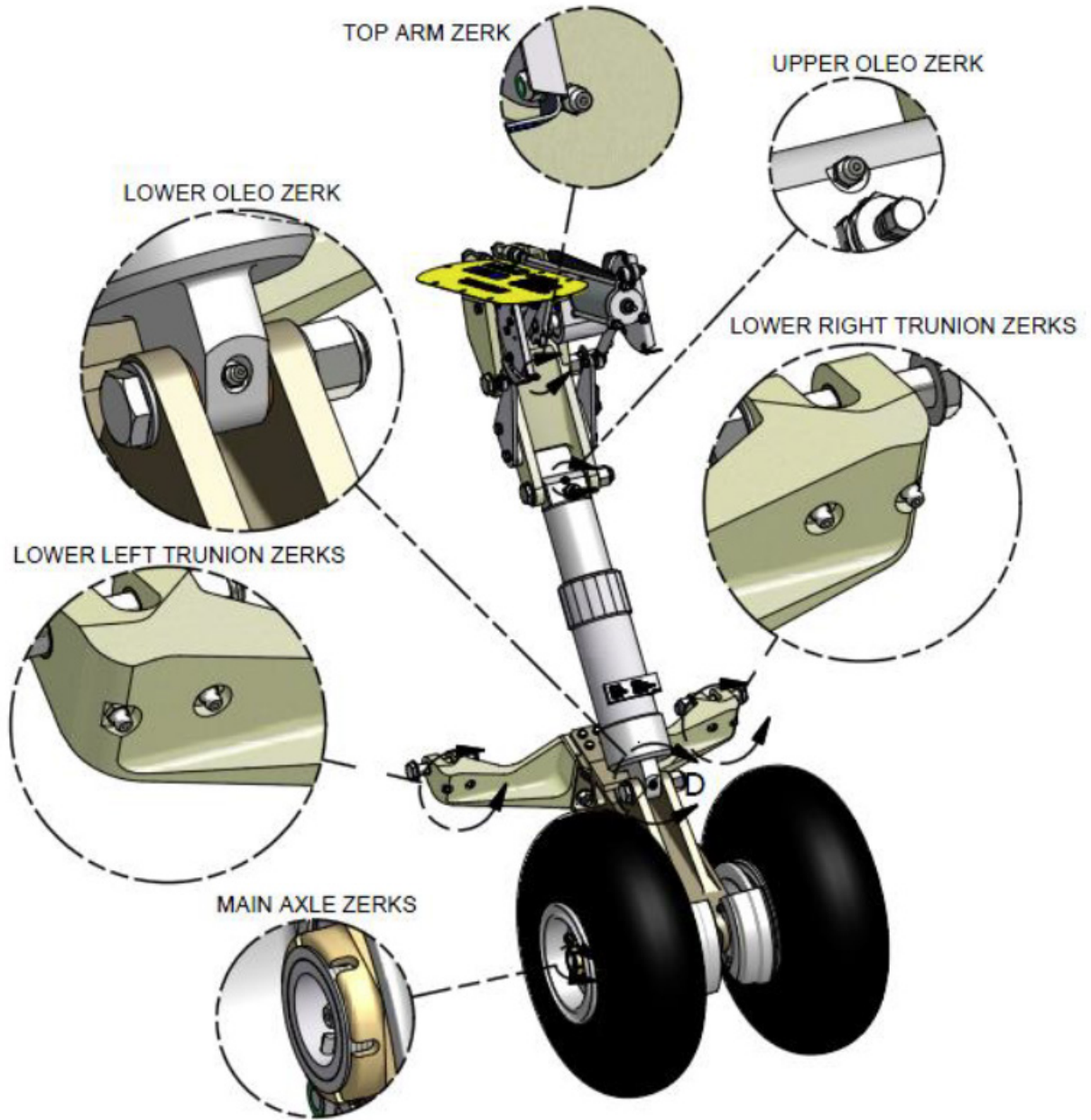
This indicator consists of colored bands that rotate with the drive shaft allowing the pilot to visually determine the position of the main landing gear by looking at a placard on the deck of the float.

Since the actuator rotates through approximately 193 degrees, the rod linkages and the actuating arm pass an over center point, preventing reverse driving of the rack and pinion actuator in both the fully extended and fully retracted positions. The actuator rotation is adjusted by setscrews that determine the length of travel of the actuator pistons. Providing an over center up-lock prevents inadvertent main gear extension in the case of a hydraulic failure.

As a secondary safety to ensure the geometry remains over center with a hydraulic failure, a spring is installed on the actuating arm preventing motion of the rack and pinion actuator. Since the retraction mechanism is over center, the weight of the landing gear and oleo, when retracted, also prevent the retraction mechanism from rotating past the over center point.



## MAIN GEAR GREASE POINT LOCATIONS



**FIGURE 4-3 MAIN GEAR GREASING**

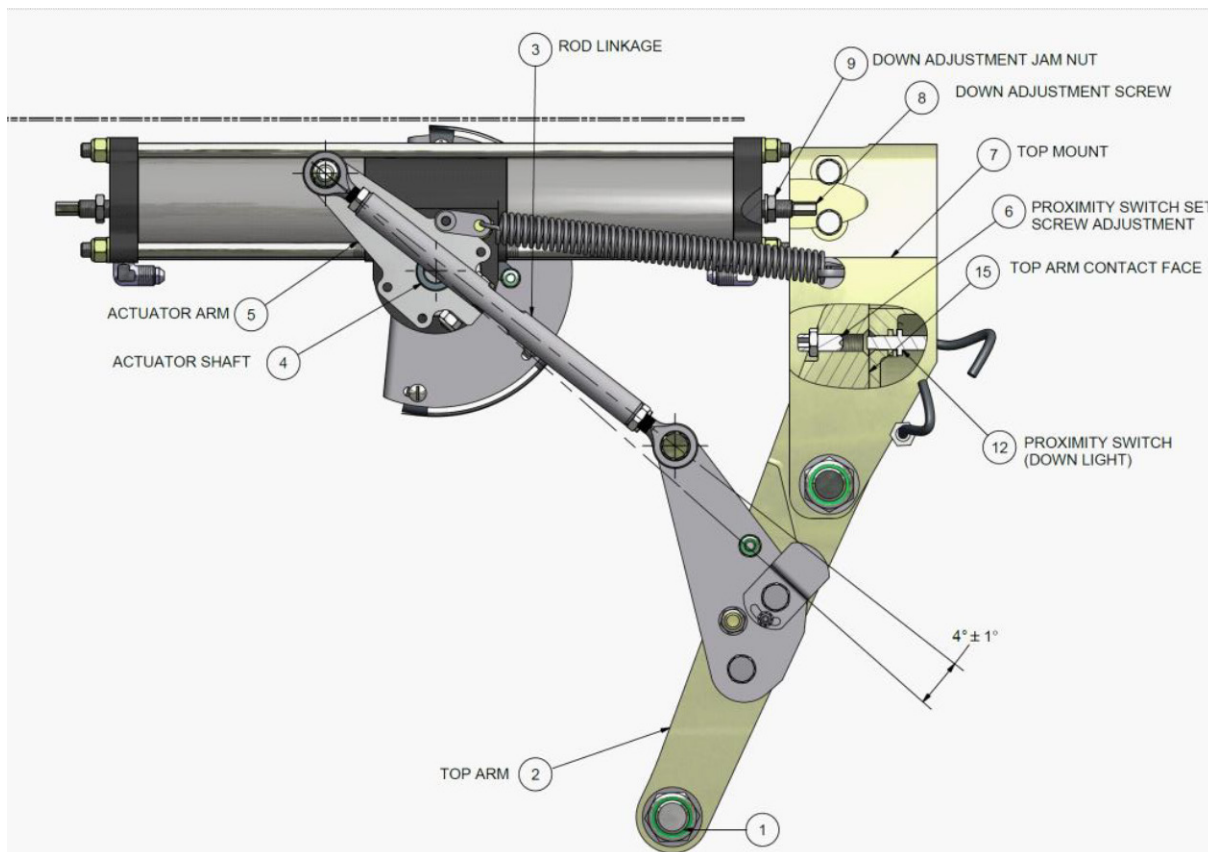
In addition to the over center locking provided by the rod linkages and actuator arm for the gear extended position, a second down locking method is provided as well. The geometry of the main gear drag link, oleo-pneumatic shock strut and the top arm assembly, provide an additional over center locking method.

The force vector from the oleo, (directed in line with the centerline of the oleo assembly) rotates the contacting face on the top arm assembly into contact with the main gear top mount at all positions of oleo stroke. This transfers the landing load into a structure designed to withstand the generated landing forces, as well as prevents the top arm from rotating and collapsing the main landing gear.

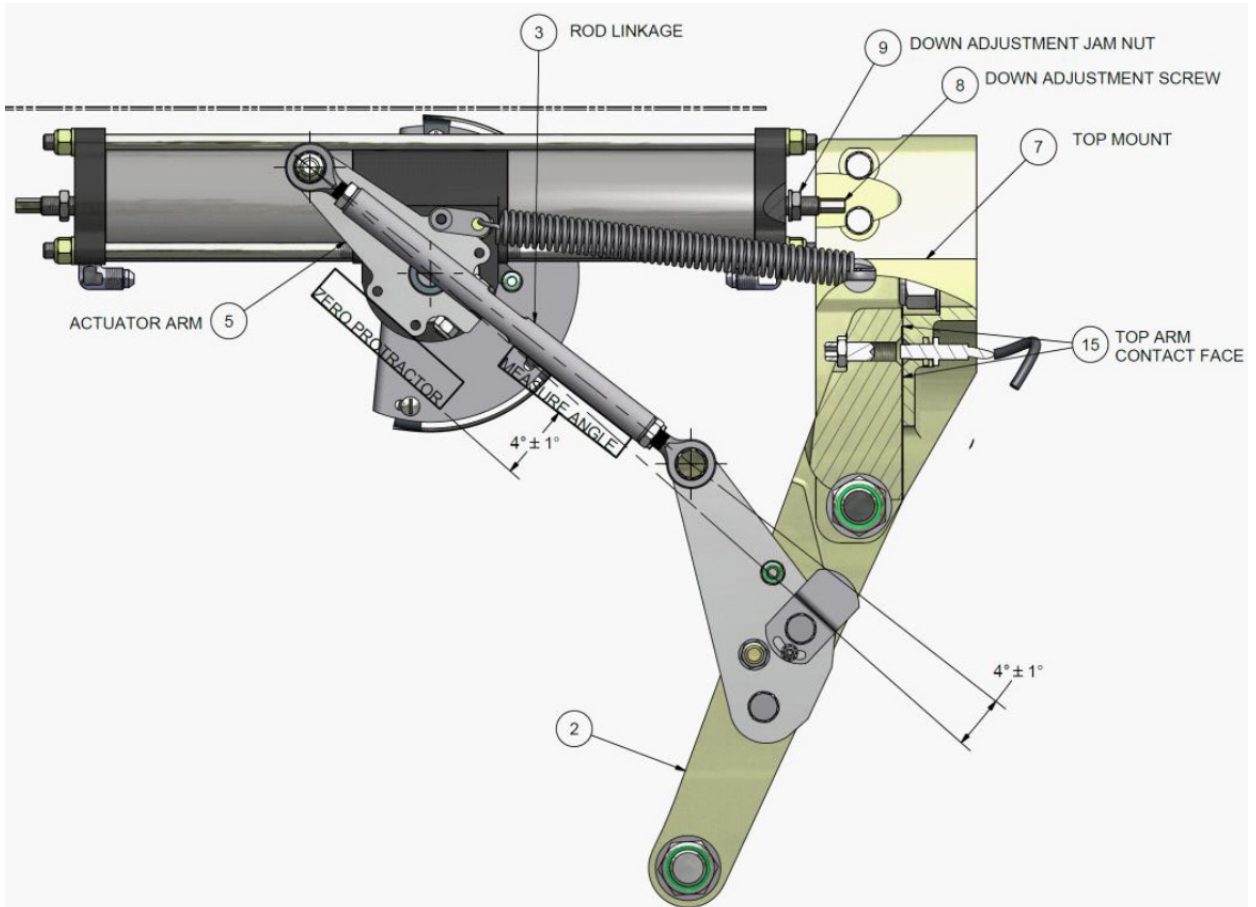
There are two proximity switches on each main gear unit. One for sensing gear up position, and the other for gear down position. These are easily replaceable and can essentially be adjusted during maintenance, see figure 4-4A and 4-5. The proximity sensors have a built in LED to indicate when they are sensing the gear position. This feature greatly aids in the setup and servicing of the sensors.

There are several service points on the main landing gear to pay attention to during maintenance. Grease zerks are located on the pivots of the main gear draglinks, each wheel axle, top and bottom pivot points on the oleo-pneumatic shock strut, and the rotation point of the top arm assembly, see figure 4-3. The adjustable rod end bearings are permanently sealed and do not require servicing. Inspect the rod ends for freedom of movement and corrosion. Replace the rod ends when necessary. Depending on the operating environment, greasing requirements may vary. Highly corrosive environments, such as salt water, may require more frequent inspections. Regardless, the gear should be inspected visually at least every 25 hours for cleanliness and proper lubrication.

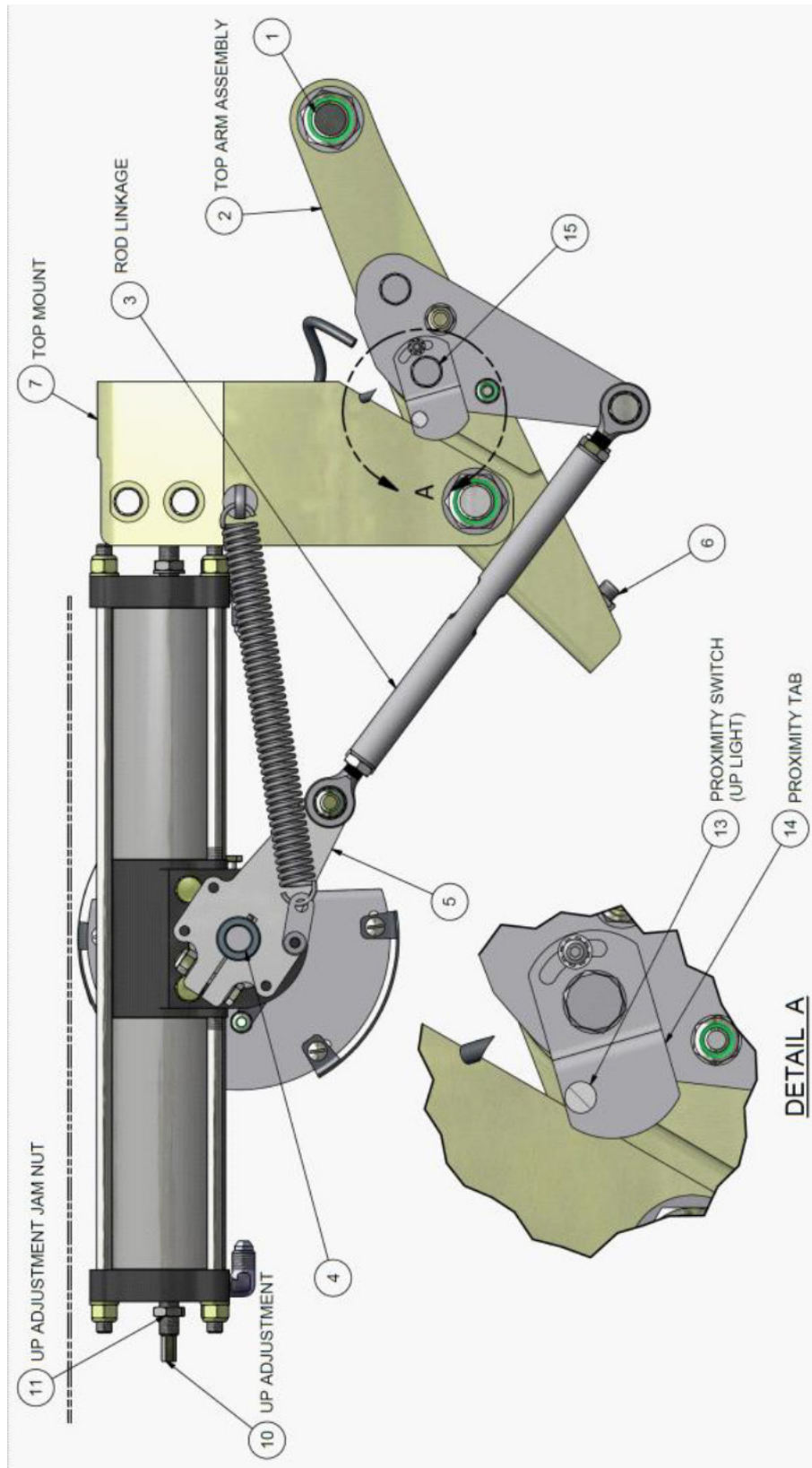
**Note:** If replacing any of the (4) bushings located within the pivot arm which are serviced by the trunion zerks (see Figure 4-3), the internal grooves must be aligned to the zerk fitting and a grease hole must be drilled into the bushing after insertion.



**FIGURE 4-4A MAIN GEAR ADJ. DOWN**

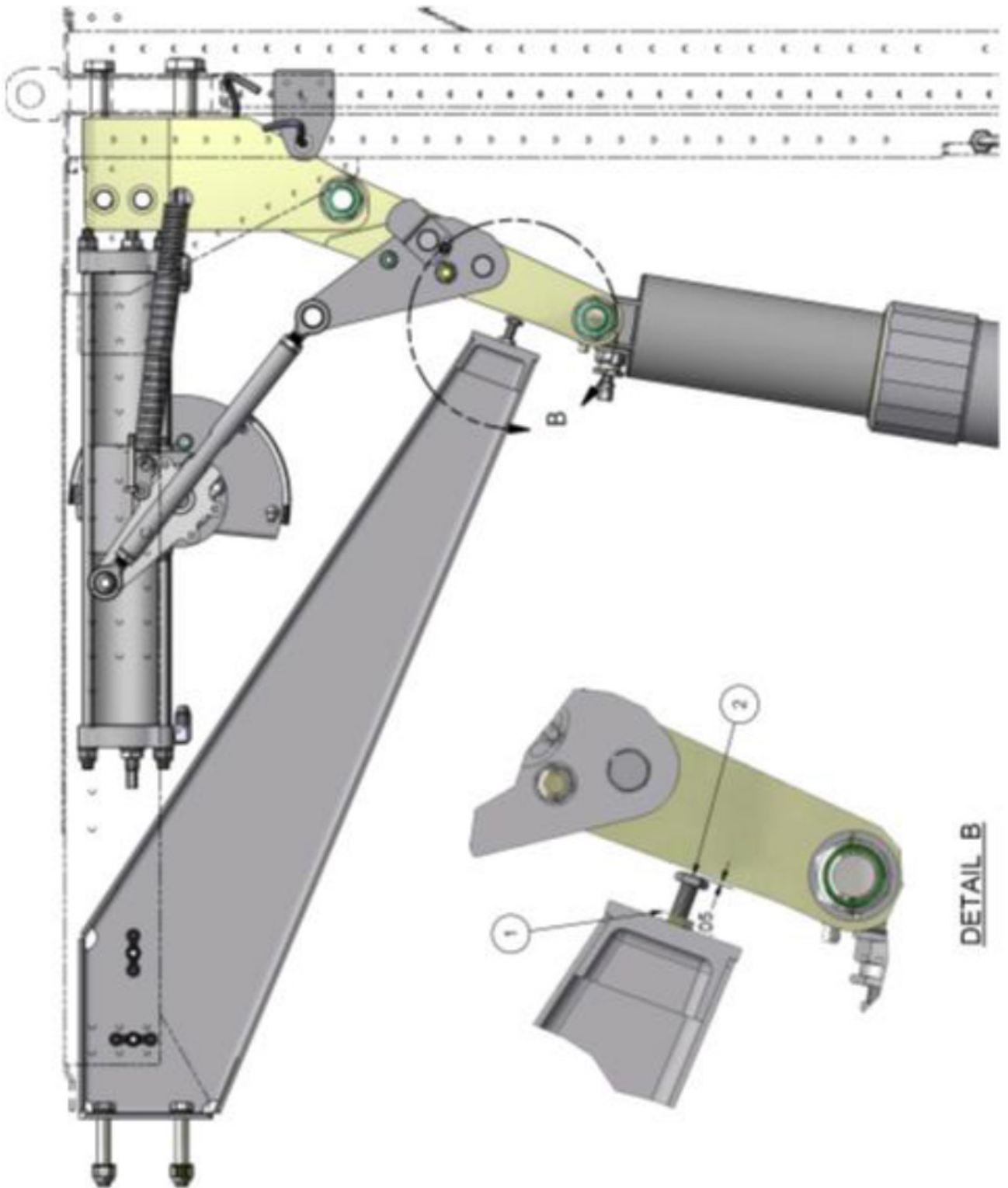


**FIGURE 4-4B MAIN GEAR ADJ. DOWN**



**FIGURE 4-5 MAIN GEAR ADJ. UP**





**FIGURE 4-6 MAIN GEAR DOWN STOP ADJ.**

## 4.2 MAIN GEAR ASSEMBLY SETUP AND ADJUSTMENT

Put aircraft on jacks to allow free extension and retraction of the landing gear. Use safe operating practices when working around moving hydraulic components. The actuators operate at high pressures and generate high forces when repositioning the landing gear.

Adjusting the Gear Down position:

(See figures 4-4A and 4-4B)

1. Bleed pressure off the hydraulic lines by moving emergency gear position selector both directions to Up and Down. This will relieve pressure in the lines allowing hydraulic lines to be unhooked without spilling fluid that is under pressure, Item 1. Leave emergency gear position selector in Up position to allow actuator movement.
  2. Remove the AN12 bolt at the top of the oleo shock strut attaching it to the top arm assembly, Item 1. This will allow the retraction mechanism to be repositioned by hand without having to move the weight of the tires, oleo and drag link assembly. Place a rag between the drag link and the bulkhead as the gear will rotate and make contact with bulkhead, possibly scratching the finish.
  3. Remove the 4 nuts connecting the rod linkages (Item 3) to the actuator arms (Item 5). Remove the rod linkages from the arms. (Note: There are qty 2 NAS1149F0463P washers between the rod end and the actuator arm).
  4. Remove the spring attached to the actuator arm.
- Note: Steps 5 through 16 are for re-rigging the actuator. If no changes are done to actuator, skip to step 17.
5. Loosen the AN4 bolt and nut holding the actuator arms (Item 5) to the actuator shaft. Remove the two arms from the shaft being careful not to lose the parallel keys. It is not necessary to remove the visual gear position indicator assembly from the outboard actuator arm.
  6. Remove the qty 4, 5/16-18 bolts, that hold the actuator into the channel that runs across the top of the wheel well.
  7. Allow the actuator to drop down from channel and remove the up and down hydraulic lines.
  8. Note: The actuator should not need adjustment while in service. The only time adjustment should be necessary is when the actuator is disassembled in order to replace internal seals. Assuming this has been done the remaining steps are for re-rigging the actuator to be installed back in the float.
  9. With the actuator assembled and removed from float, attach Wipaire Tool 1004800 to the actuator, taking note that the FORWARD arrow is pointing forward on the actuator. Use the 5/16-18 bolts to attach the tool to the actuator.
  10. Rotate the actuator shaft fully to the DOWN position. If the two keyway slots do not line up when the actuators internal piston contacts the "DOWN" adjustment set screw (Item 8), the actuator needs adjustment. It may be necessary to use one of the actuator arms removed in step 5 to help rotate the actuator.
  11. To adjust the "DOWN" position, loosen the "DOWN" adjustment screw jamb nut (Item 9) and back off the adjustment screw.
  12. Align the keyway on the actuator shaft (Item 4) with the keyway on Wipaire Tool 1004800. Insert the parallel key removed in step 5 into the aligned keyways.
  13. Thread in the Down Adjustment setscrew until light contact is made between the setscrew and the actuators internal piston. Do not over tighten as the actuator cannot rotate with Wipaire Tool 1004800 and the key installed. Over tightening can damage the face of the actuator piston.
  14. With setscrew positioned against the piston face, tighten the adjustment screw jamb nut (Item 9).
  15. Repeat steps 10 - 14 for setting the UP position setscrew. (See figure 4-5)
  16. Install actuator in float by reversing steps thru 7. Safety wire 5/16-18 bolts when installed. Outer face of actuator arms should be flush to actuator shaft. It is recommended to leave the spring disconnected during gear rigging.
  17. Reattach rod linkages to actuator arms. Loosen the rod linkage jamb nuts and lengthen the rods slightly, (Item 3). Make equal adjustments to each rod.
  18. Rotate actuator arms until the internal piston is against the Down Adjustment Screw.

19. Shorten the Rod Linkage until the Top Arm Contact Face (Item 15) touches the contact face of the Top Mount (Item 7). Make equal adjustments to each rod. Actuator needs to be rotated fully against the Down Adjustment Screw.
20. Visually inspect the Rod Linkage position (Item 3) versus the actuator shaft (Item 4). When rigged correctly, the bottom edge of the rod linkage should pass through the shaft as shown in Figure 4-4A.
21. Ensure gear is in down and locked position.
22. Using a small digital protractor, the over-center angle will be verified. Lay the protractor across the bottom of the lower two screw holes in the actuator arm. Note: Older float models may not have flat spot shown; use the same location as shown. Zero the protractor. See Figure 4-4B. Then place the protractor on the top or bottom of the rod linkage. The measured angle should be  $4^{\circ} \pm 1^{\circ}$ . Repeat for the other actuator arm and rod linkage by zeroing the protractor on the other actuator arm and measuring the rod linkage angle.
23. If angle is lower than required, the down Adjustment Screw (Item 8) should be turned out to allow more rotation. If the angle is greater than required, the actuator is over-rotating and the adjustment screw should be turned in. One turn of the adjustment screw changes the angle by approximately  $2^{\circ}$ .
24. If adjustments have been made to the Down Adjustment Screw, the Rod Linkage (Item 3) may need to be shortened or lengthened so that the Top Arm Contact Face (Item 15) still makes contact with the Top Mount.
25. Repeat steps 22 through 24 until angles measure within tolerance.
26. With setscrew positioned against the piston face, tighten the adjustment screw jam nut (Item 9).
27. Preload the rod linkages by shortening each rod by 1/2 turn after the contact faces touch on the Top Arm and Top Mount. Tighten the Rod Linkage jamb nuts.
28. Check the operation of the over center down lock. As the actuator rotates causing the contact faces to touch, the actuator arm should continue to rotate and “snap” past Top Dead Center (TDC). Make sure that there is preload on the linkage rods so that contact faces remain touching past TDC. Push and pull on the Top Arm Assembly (Item 2) to ensure it is locked over center. The Top Arm Assembly needs to be contacting the Top Mount (Item 7) when the gear is extended to properly transfer the landing loads. Ensure Top Arm and Top Mount are making contact by sliding a 3-inch wide piece of paper in (See Figure 4-4B and photo on this page), then moving gear to down and locked position. If paper is tight, gear is rigged correctly. If paper is able to slide out, then the Top Arm and Top Mount are not making proper contact and need further adjustment.
29. Reattach spring.



30. Loosen the (Fig 4-6, Item 1) jam nut on the Main Gear Down Stop Assembly, and screw in the NAS-428 adjustment bolt (Fig 4-6, Item 2). Verify the bolt does not touch the Top Arm when gear is in the down position. When the aircraft is off the jack stands and the weight of the aircraft fully on the wheels, adjust the NAS-428 bolt to lightly make contact with the Main Gear Top Arm when the gear is in the full down position, then turn the bolt one and a half turns in so that the bolt no longer makes contact with the Top Arm. Gap should be about 0.050 inches. Tighten the jam nut.

**Note:** There are three “over center” locks on the main gear when the gear is down. The first is the over center rod linkages that are adjusted in the above steps. The second is from the spring pulling on the actuator arm when the gear is in the down position. The spring prevents the actuator from moving in the event of a loss of hydraulic pressure. The third comes in the form of the angle between the oleo-pneumatic shock strut and the Top Arm Assembly. The vector of the oleo force is “over center” about the rotation point on the Top Arm Assembly. Thus, one could effectively remove the entire gear actuator, and the geometry of the Oleo and Top Arm alone would force the contact faces of the top arm and top mount together and lock it “over center.”

There are also two “over center” locks when the gear is in the retracted “up” position. The first is a spring installed on the actuating arm that prevents motion of the rack and pinion actuator in the event of a hydraulic failure. The second over center lock comes from the geometry of the gear in the up position.

Since the retraction mechanism is driven over center, the weight of the landing gear and oleo, when retracted, prevent the retraction mechanism from rotating past the over center point. The weight of the gear wants to rotate the Top Arm Assembly, however, when rotating the Top Arm, the rod linkages must also move. The geometry is such that the rod linkages are “over center” on the actuator shaft centerline, and thus the rod linkages are trying to rotate the actuator more toward the UP position and hence force the actuator piston face into the up adjustment setscrew.

### **4.3 ADJUSTING THE GEAR UP POSITION**

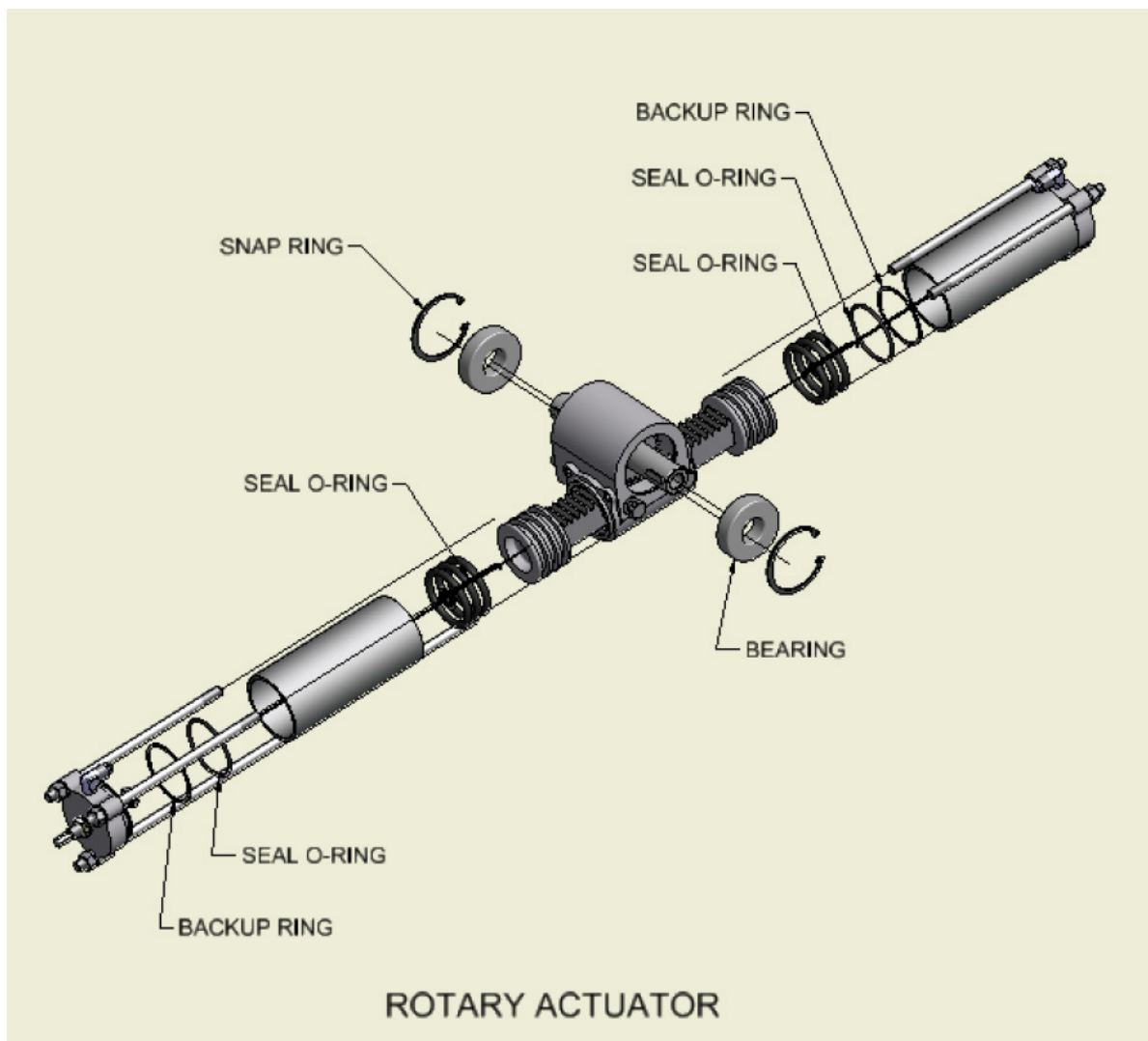
1. DO NOT adjust the rod linkages (Item 3) when setting the over center up adjustment.
2. Rotate the actuator rotation arm fully toward the gear up position.
3. When the actuators internal piston contacts the “UP” adjustment setscrew, check to make sure all the linkages have rotated past Top Dead Center (TDC) by pushing and pulling on the Top Arm Assembly. The “UP” adjustment screw (Item 10) should not need to be adjusted if properly set using Wipaire Tool 1004800 during the actuator maintenance. (If it is found that one can reverse drive the rotary actuator and pull the gear down by hand, the rod linkage and the actuator arms have not moved past TDC. Re-check the position of the “UP” stop using Wipaire Tool 1004800. If the “UP” position is found to be correct, look for signs of damage in the floats as something is out of position preventing the stop setting using Tool 1004800 from being correct. Call Wipaire’s Customer Service Department for specific instructions.)
4. Bleed air from hydraulic system by actuating the gear several times with the electric hydraulic pumps. See Chapter 5, Section 5.1, for specific bleeding instructions.
5. If it is necessary to adjust gear up and down position switches proceed to next section. If not, lower gear and reattach oleo shock strut to top arm assembly. When aircraft weight is fully on the wheels, remember to set the NAS-428 bolt on the Main Gear Down Stop Assembly (refer to Section 4.2 Step 30).

### **4.4 ADJUST MAIN GEAR UP AND DOWN POSITION SWITCHES**

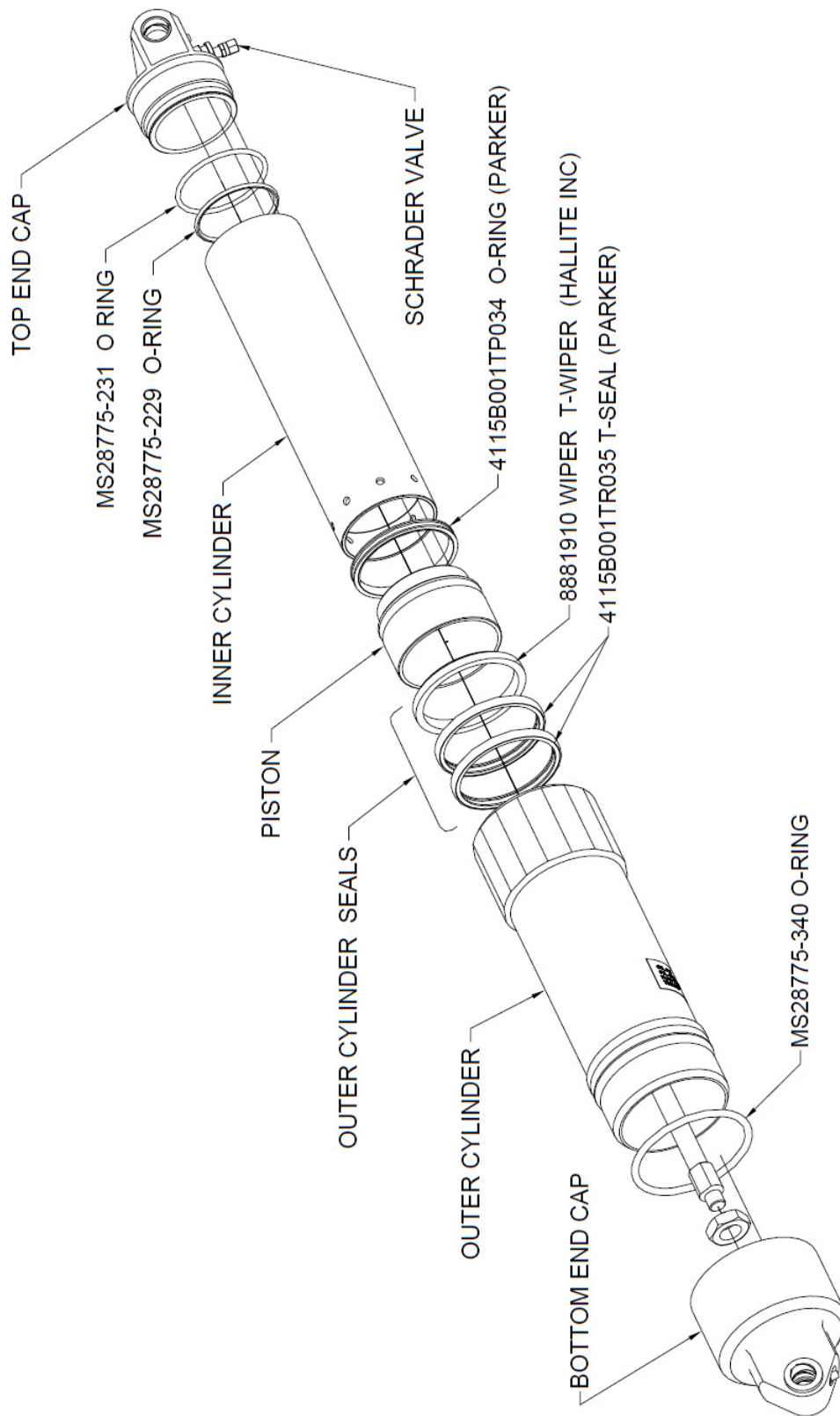
1. With the aircraft still on jacks, position the gear in the “UP” position. This allows access to the gear down proximity switch.
2. Loosen the jam nut on the Gear Down Proximity Switch located on the back of the Main Gear Top Mount. Thread the Gear Down Proximity Switch in or out until the face of the sensor is flush with the face of the Main Gear Top Mount. Reference Figure 4-4B. Tighten the jam nut on the proximity switch to 10 +/- 3 inch-pounds.
3. Thread out the Set Screw Adjustment (Item 6), located on the Top Arm Assembly (Item 2).
4. Position the gear in the “DOWN” position. With the aircraft master switch on, thus providing power to the proximity switch, thread the Set Screw Adjustment (located on the Top Arm Assembly) in until the LED light built



- into the proximity switch initially illuminates with the gear arm in the full down over center locked position, then thread the set screw in an additional half turn.
5. Reposition the gear to the "UP" position.
  6. Loosen the jam nuts on the gear up proximity sensor.
  7. Adjust the gear up proximity sensor switch to have between a 0.030 - 0.060" gap between the proximity sensor plate and the proximity sensor. Tighten the jam nuts on the proximity sensor to 10 +/- 3 inch-pounds.
  8. At this point, check to insure that the built in LED on the proximity sensor is illuminated when the sensor plate is rotated in front of the sensor.
  9. With the gear in the full up position, loosen the AN6 bolt holding the proximity sensor plate to the Main Gear Top Arm and the socket head cap screw that prevents rotation of the sensor plate.
  10. Rotate the sensor plate so that the sensor is near the edge of the plate with the gear in the up position. Reference Figure 4-5 inset.
  11. Tighten the AN6 bolt, socket head cap screw, and re-safety AN6 bolt.
  12. Check for proper light illumination on the gear selector in the cockpit in both the up and down position.
  13. If necessary, reattach the oleo shock strut to the Top Arm Assembly.
  14. Remove aircraft from jack stand.



**FIGURE 4-7 ROTARY ACTUATOR**



OLEO SHOCK STRUT

FIGURE 4-8 MAIN SHOCK STRUT

## **4.5 EMERGENCY GEAR OPERATION**

An emergency hand pump is provided in case of total electric pump failure or loss of fluid. The emergency hand pump draws hydraulic fluid from the bottom of the hydraulic power pack reservoir. The hydraulic power pack electric pumps have fluid pickup tubes that do not reach the bottom of the hydraulic fluid reservoir. This prevents the electric pump from being able to pump all the fluid out of the system.

The remaining small reserve quantity of fluid below the electric pump pickup tube is then reserved exclusively for the emergency hand pump. The quantity of reserve fluid below the electric pump pickup tubes is sufficient to raise or lower the landing gear with the hand pump alone.

THIS PAGE INTENTIONALLY LEFT BLANK

## CHAPTER 5 HYDRAULICS

### CONTENTS

5.0 HYDRAULIC SYSTEM BASIC DESCRIPTION.....	54
5.1 BLEEDING THE HYDRAULIC SYSTEM .....	57

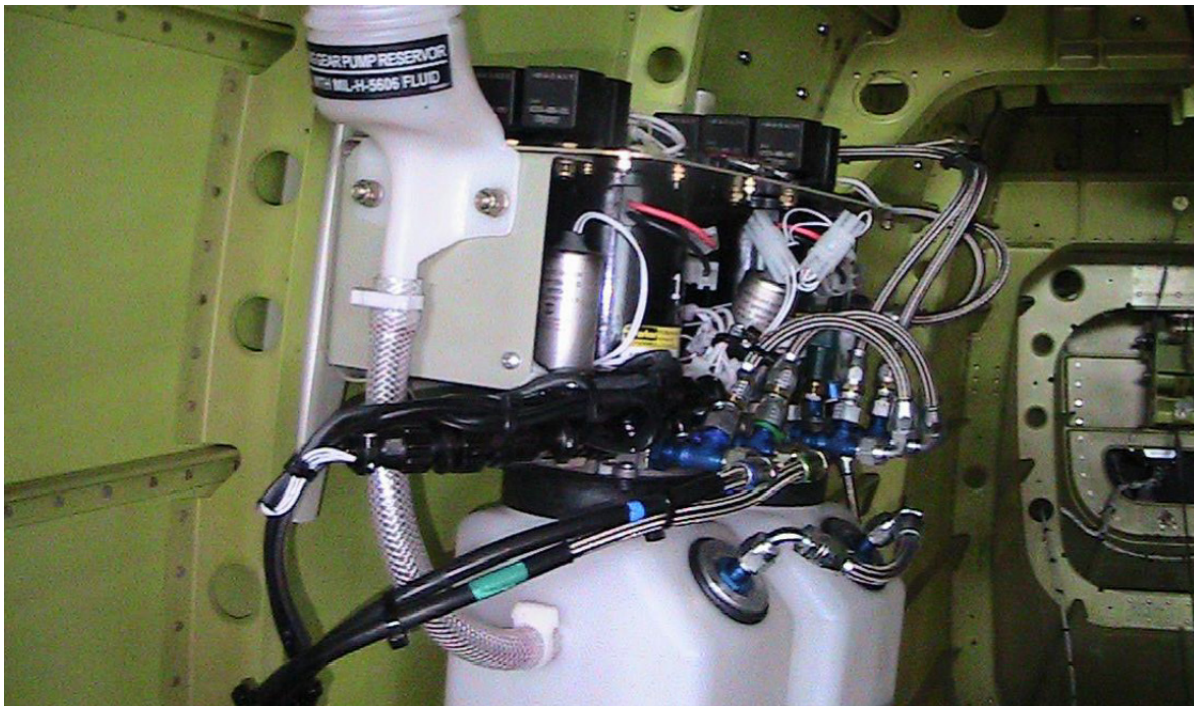
## 5.0 HYDRAULIC SYSTEM BASIC DESCRIPTION

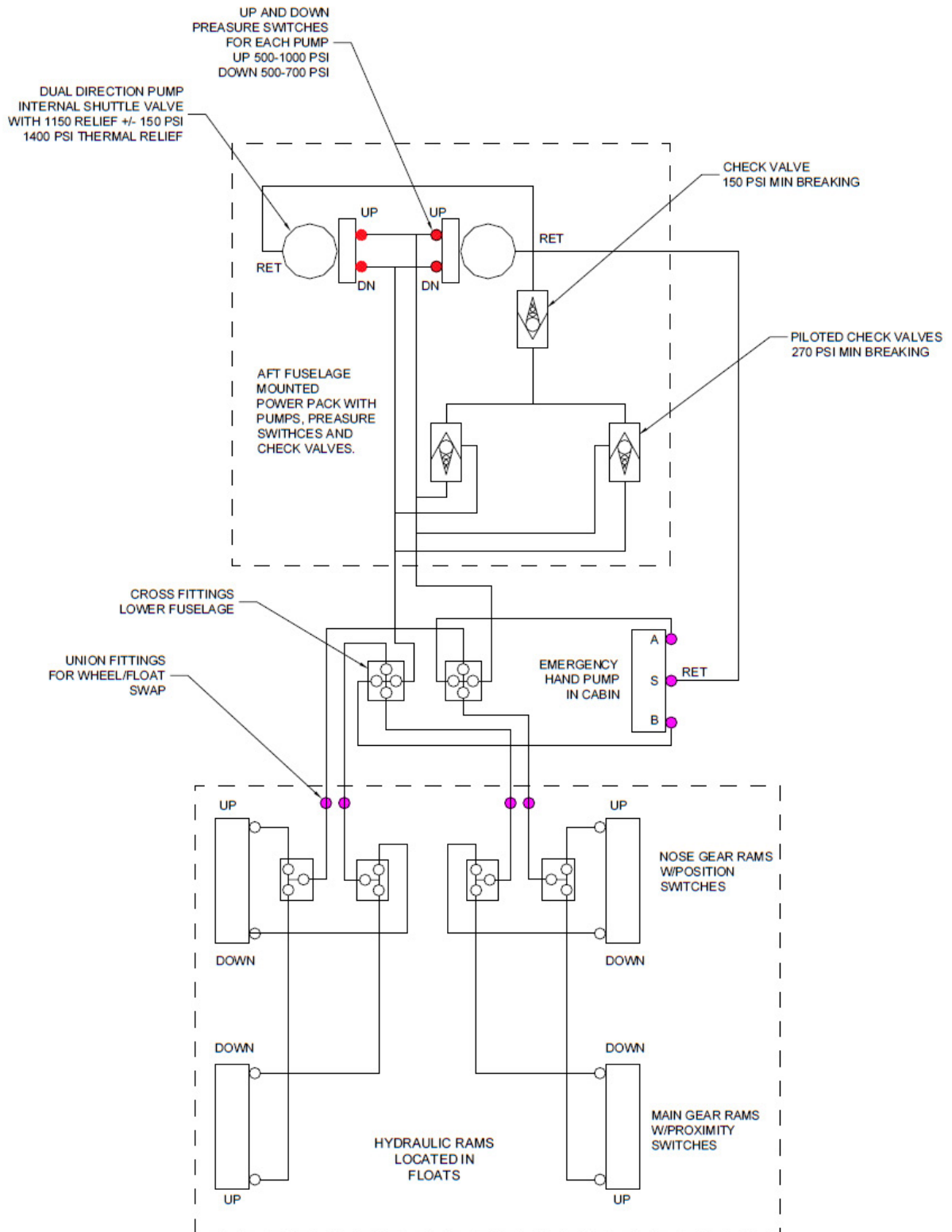
A pressure of between 500 psi and 700 psi in the DOWN position and 500 psi and 1200 psi in the UP position is maintained in the supply line. When the pressure falls below 500 psi in the UP and DOWN position, the pressure switch activates the pump solenoid, providing power to the pump.

When the pressure reaches 700 psi in the DOWN position and 1200 in the UP position, the pressure switch deactivates the solenoid and the pump motor stops. A check valve on the output side of the pump retains pressure in the system while the pump is off.

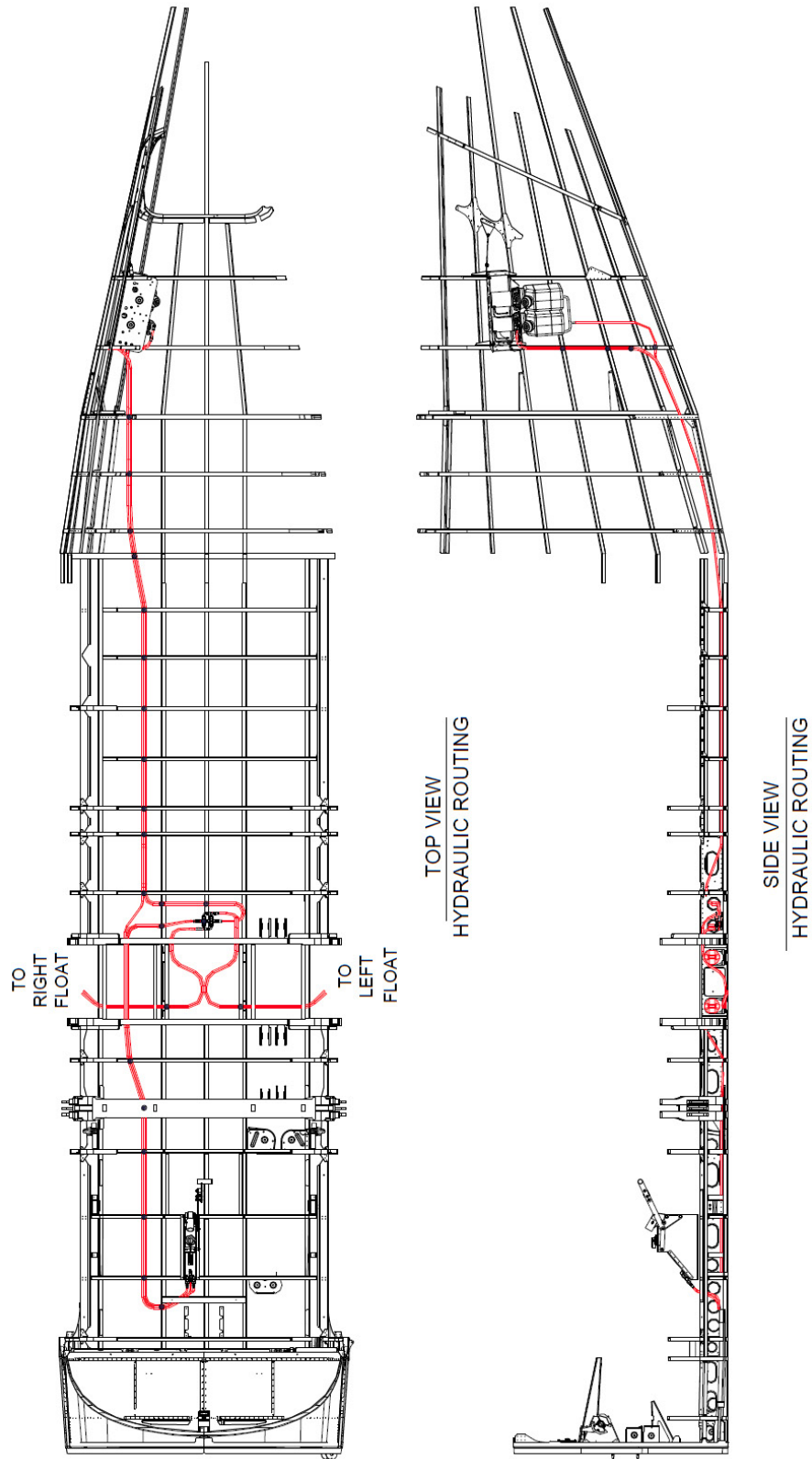
The pump has an interval relief valve that directs fluid back to the un-pressurized pump reservoirs when the line pressure exceeds 1400 psi. The system also has an internal relief valve to protect against thermal expansion when line pressure exceeds 1900 psi.

The pilot-line, attached to each of the piloted check valves, prevents thermal expansion of hydraulic fluid from activating the Up and Down pressure switches. If the Up and/ or Down switch were to be activated from thermal expansion, the pump would not run when commanded by the gear selector switch.





**FIGURE 5-1 HYDRAULIC SCHEMATIC**



**FIGURE 5-2 HYDRAULIC PLUMBING**



## **5.1 BLEEDING THE HYDRAULIC SYSTEM**

The system automatically bleeds, provided sufficient oil is maintained in the reservoir. To check the fluid level, fill the reservoir through the servicing point on the power pack assembly with MIL-H-5606 hydraulic oil and cycle the gear.

If the reservoir empties, stop the cycle by pulling the pump motor circuit breakers. Fill the reservoir again and complete the cycle. Continue this procedure until the fluid level in the reservoir stabilizes (it will vary in level between gear up and down positions).

If the fluid level continues to decline during gear cycles, check for external leaks. When the fluid level stabilizes, fill the reservoir to the normal operating range as placarded on the pump reservoir.

THIS PAGE INTENTIONALLY LEFT BLANK

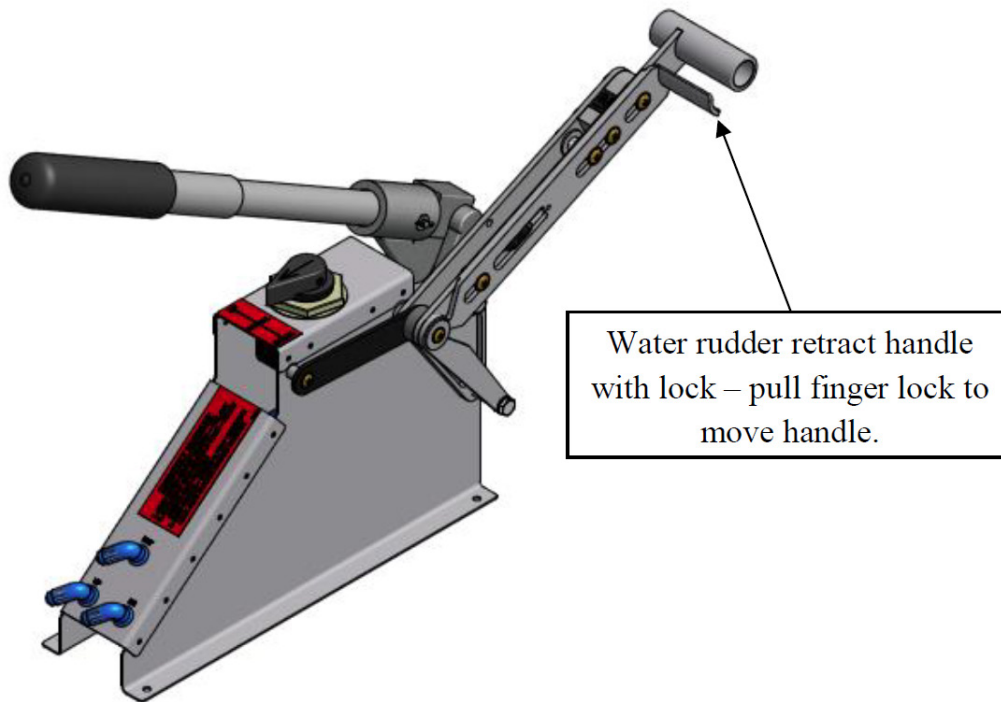
## CHAPTER 6 WATER RUDDER

### CONTENTS

6.0 BASIC DESCRIPTION .....	60
-----------------------------	----

## 6.0 BASIC DESCRIPTION

The water rudder retract system is manually operated by a lever through a system of cables and pulleys.



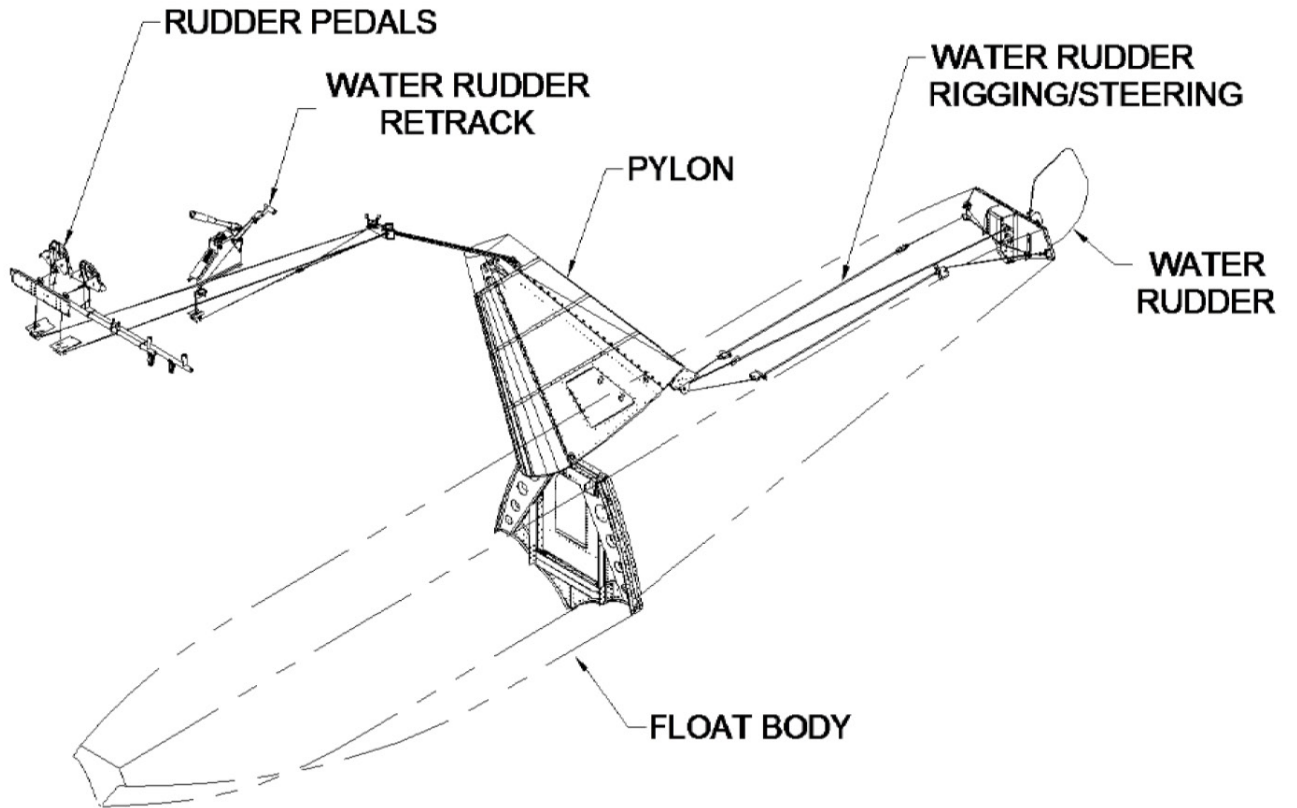
**FIGURE 6-1 WATER RUDDER RETRACTION & EMERGENCY GEAR PUMP HANDLES**

Steering is directed from the aircraft rudder steering system. The controls are interconnected and seamless to the operator aside from retraction and extension of the water rudder.

### **WATER RUDDER RIGGING**

All cables in the water rudder steering and retract system should be rigged to  $30 \pm 5$  lbs. The downward travel on the water rudder should be set according to drawing 1004211.

Water rudders should be centered, when the air rudder is centered, by adjusting turnbuckles. There is no left or right rigging adjustment related to the maximum travel of the water rudder system. Verify air rudder rigging has been modified for floatplane operation per drawing 1002632.



**FIGURE 6-2 WATER RUDDER CABLE ROUTING**

THIS PAGE INTENTIONALLY LEFT BLANK

## CHAPTER 7 ELECTRICAL

### CONTENTS

7.0 ELECTRICAL SYSTEM BASIC DESCRIPTION .....	64
---	----

## 7.0 ELECTRICAL SYSTEM BASIC DESCRIPTION

For detailed information regarding the electrical system, refer to Installation Drawing 1004472. The following electrical systems are added with the installation of Wipline 7000 floats on the Quest Kodiak 100:

1. 24V DC Hydraulic pumps (2), each pump with its own dedicated circuit breaker.
2. Gear selector head, for changing pump flow directions to actuate the landing gear up and down, and indicated gear position.
3. Emergency Trim Timer Override System (ETTOS), for bypassing the aileron trim timer if primary aileron system fails.

### ELECTRIC HYDRAULIC PUMPS

The installed 24V DC electrically reversing hydraulic pumps are wired independently to allow failure of one pump without affecting the other pump. The pump is electrically shut-off in the up and down directions by a fluid pressure switch that cuts pump power when sufficient hydraulic pressure is obtained in the gear system. Gear swings should take less than 45 seconds with both pumps operating. If the gear cycle time is greater than 45 seconds it is likely that one pump is not pumping.

This can be verified by pulling each pump breaker to see if the system functions on one pump, but not the other.

### GEAR SELECTOR HEAD

The installed gear selector head is similar to units used in several other models of Wipline floats. This selector head switches current directions to the electric pumps, reversing their pumping direction. It also indicates gear positions using four blue and four green incandescent lights. The lights for the nose gear are turned on with a magnetic switch that senses a magnet in the hydraulic cylinder piston. The lights for the main gear position are triggered by inductive proximity switches that are triggered by metal flags on the main gear arm. Lights are cartridge style and can be replaced by pulling them out from the bezel.

### EMERGENCY TRIM TIMER OVERRIDE SYSTEM (ETTOS)

The ETTOS system consists of a guarded switch that when activated, bypasses the timer on the aileron trim system. This allows the aileron trim tab to move as long as the trim switch is depressed. When the system is not activated the trim tab stops moving after 1 second and requires the pilot to depress and then release the trim rockers to get trim motion in discrete steps.

The emergency trim timer override system is easily installed and removed from the Quest Kodiak aileron trim system. To install the bypass switch:

1. Locate aileron trim timer on the underside of the panel that the aileron trim switch is mounted. It is a square box about 2in x 2in x 0.5in.
2. Follow the 4 wires coming off of the timer box to 4 pin molex connector J227E.
3. Disconnect the molex connector and insert the molex connectors from the pre-wired bypass switch (PN 1004634).
4. Route the wires for the guarded switch to the panel.
5. Install switch in panel below and to the left of the control yoke per drawing 1004469.

See drawing 1004472 for specific connector schematic. Removal is the reverse of installation. Install cover into any holes in the panel.

To check the function of this system the switch should be activated and the trim rocker switches depressed. If the aileron trim indication on the PFD, and the trim tab, move continuously the system is functioning correctly. If the trim indicator, or tab, do not move continuously the switch and associated connections should be checked. This system should be checked for proper function at every 100 hour inspection and annual.



## CHAPTER 8 HARTZELL 3 BLADE PROPELLER

### CONTENTS

8.0 HARTZELL 3 BLADE PROPELLER .....	66
--------------------------------------	----

## **8.0 HARTZELL 3 BLADE PROPELLER**

Refer to document number 1009486 for information and procedures if the Hartzell 3 blade propeller is installed.

## CHAPTER 9 RECOMMENDED PROCESSES, PRODUCTS, & INSPECTION CHECKLISTS

### CONTENTS

9.0 SERVICING INSTRUCTIONS .....	68
9.1 CORROSION REMOVAL .....	71
9.2 MAINTENANCE CHECKLIST.....	72
9.3 FLOAT REMOVAL AND RE-INSTALLATION GUIDE.....	78
9.4 WEIGHING PROCEDURES FOR QUEST KODIAK ON WIPAIRE 7000 AMPHIBIAN FLOATS .....	89
9.5 WIPAIRE FLOATS SPECIAL TOOLS.....	90

## 9.0 SERVICING INSTRUCTIONS

As coded in the Inspection Time Limits chart in this section, there are items to be checked each 25, 50, 100, and 200 hours. Also, there are notes on special items which may require servicing at more frequent intervals.

- \* When conducting an inspection at 25 hours, all items marked for 25 hours would be accomplished.
- \* at 50 hours, the 25 and 50-hour items would be accomplished.
- \* at 100 hours, the 25, 50, and 100-hour items would be accomplished.
- \* at 200 hours, the 25, 50, 100 and 200-hour items would be accomplished.
- \* A complete inspection (Annual Inspection) would include all 25, 50, 100, 200 hour items.

Below is a list of recommended lubricants and “protection” products when servicing float hull, amphibious components. This lists products used by Wipaire during assembly of the floats.

There may be equivalent products just as satisfactory for protection. However, it is recommended if trying different products, to inspect them frequently so as to determine their effectiveness.

### **Protection of nuts, bolts, hydraulic lines, metal surfaces, or electrical connections**

Dinitrol AV30

Dinol Group

CRC – SP400 Soft Seal

CRC Industries

### **General Lubricants**

LPS 1, LPS 2 and LPS 3

LPS Industries

### **Wheel Bearings, Main Gear Retract Mechanism, Nose Gear Pivot and Rod Ends**

\*HCF Grease, P/N 605

HCF Industries

\*Aeroshell 22

Shell Global Solutions

\*Green Grease, Multi-Purpose

Green Grease Inc.

\*Aviation Grease SHC 100

ExxonMobil Aviation Lubricants

\* If existing grease cannot be identified you must lubri-flush all float grease fittings until visibly exhausting all old grease and new grease is coming out. Additionally if you cannot determine existing grease in wheel bearings, completely clean and repack bearings with new grease.

### **Metal Corrosion Protection**

Boeshield T9 Rust Protection

Boeing Company

Corrosion X

Corrosion Technologies Corporation

ACF-50 Rust Protection

Tef-Gel  
Ultra Safety Systems, Inc.

**Float Sealant**

890 B2 or B4  
Pro Seal Company

PR 1440 C  
PPG Aerospace

RTV Silicones  
General Electric

SIKAFLEX 201 or 252  
Sika Manufacturing

**Hydraulic Fluid**

Mil-H-5606

**Electrical Insulating Compound**

Dow Corning 4 (DC4)  
Dow Corning Corporation

**Brake Caliper Grease**

STA-Lube

**Bolt Torque**

Bolts in Critical Areas - For common, correct torque when installed, or when visual inspection indicates a need for a torque check.

Bolt and nut torque should be applied per the specified part installation drawing specifications. If no torque is specified, apply torque based on hardware application from tables below.

<b>**TENSION APPLICATION—FINE THREAD</b>		
<b>NUT-BOLT SIZE</b>	<b>TORQUE LIMITS IN-LBS</b>	
	<b>MIN.</b>	<b>MAX.</b>
8-36	12	15
10-32	20	25
1/4-28	50	70
5/16-24	100	140
3/8-24	160	190
7/16-20	450	500
1/2-20	480	690
9/16-18	800	1000
5/8-18	1100	1300
3/4-16	2300	2500
7/8-14	2500	3000
1-14	3700	5500
1 1/8-12	5000	7000
1 1/4-12	9000	11000

<b>**SHEAR APPLICATION—FINE THREAD</b>		
<b>NUT-BOLT SIZE</b>	<b>TORQUE LIMITS IN-LBS</b>	
	<b>MIN.</b>	<b>MAX.</b>
8-36	7	9
10-32	12	15
1/4-28	30	40
5/16-24	60	85
3/8-24	95	110
7/16-20	270	300
1/2-20	290	410
9/16-18	480	600
5/8-18	600	780
3/4-16	1300	1500
7/8-14	1500	1800
1-14	2200	3300
1 1/8-12	3000	4200
1 1/4-12	5400	6600

<b>**TENSION APPLICATION—COARSE THREAD</b>		
<b>NUT-BOLT SIZE</b>	<b>TORQUE LIMITS IN-LBS</b>	
	<b>MIN.</b>	<b>MAX.</b>
8-36	12	15
10-32	20	25
1/4-28	40	50
5/16-24	80	90
3/8-24	160	185
7/16-20	235	255
1/2-20	400	480
9/16-18	500	700
5/8-18	700	900
3/4-16	1150	1600
7/8-14	2200	3000

<b>**SHEAR APPLICATION—COARSE THREAD</b>		
<b>NUT-BOLT SIZE</b>	<b>TORQUE LIMITS IN-LBS</b>	
	<b>MIN.</b>	<b>MAX.</b>
8-32	7	9
10-24	12	15
1/4-20	25	30
5/16-18	48	55
3/8-16	95	100
7/16-14	140	155
1/2-13	2440	290
9/16-12	300	420
5/8-11	420	540
3/4-10	700	950
7/8-9	1300	1800

\*\* A Torque of 80% should be used when Tef-Gel is applied to the bolt.

## 9.1 CORROSION REMOVAL

Reference the Wipaire Structural Repair Manual (SRM) for allowable corrosion/material loss limits. Corrosion is usually detected visually, which is why Wipaire strongly recommends the previous cleaning and inspection procedures. It can appear as a white or pale green powder, discoloration of the metal surface, or bubbles and blisters under the surface of the paint.

Light corrosion is removed by gentle sanding or chromic acid. Moderate and severe corrosion (blistering, flaking and pitting) can be removed by heavier sanding or grinding.

Reinforcement or replacement of affected areas may be necessary if there is critical loss of strength in parent metal and depends on location and other factors.



**Pylon before repair**

After removing the corrosion, restore the area to the original finish, like prime and enamel, or coat the metal with a waterproof grease. CORROSION X, or equivalent, should also be applied to stop corrosion and repel moisture and contaminants.



**Pylon fully repaired**

## 9.2 MAINTENANCE CHECKLIST

INSTRUCTIONS / PROCEDURES		HOURS					MECHANIC	
		25	50	100	200	ANN	RT	LT
<b>General</b>	Wash aircraft and floats with fresh water and inspect surfaces, hardware and strut connections for corrosion.	If the airplane is exposed to salt or polluted water, the chance for corrosion increases dramatically. Daily basic cleaning is essential.	X or more often				X	
	Check installed placards against the AFM/POH Supplement Section 2, and installation drawings.			X			X	
<b>Hulls &amp; Struts</b>	Float Installation:	Float exterior – inspect for damage, wrinkled metal, corrosion, paint loss, etc.		X			X	
	Boarding steps disassemble as needed and grease the step-slide tubes.			X			X	
	Pylon, Inspect pylon structure and attachment to float and aircraft.	Remove forward and aft pylon fairings and open rope access door. Inspect door for security. Inspect overall inboard and outboard skins and fairings for damage or corrosion. Inspect pylon and drag brace structure for corrosion or deformation. Inspect all attaching hardware for security, damage, and corrosion. Apply ACF 50 to Pylon Float Deck attach point hardware prior to reinstallation.					X	
	Disassemble and grease the flying wire clevis bolts/pins.	Spreader Bars: inspect for loose screws and cracks.					X	
		On the aircraft and floats: re-coat exposed hardware with suitable coating for corrosion per section 9.0 Servicing Instructions of this manual.		X			X	
<b>Float Interior</b>	Float Structure (Interior):	Closely inspect for wrinkled metal & cracked flanges.		X			X	



INSTRUCTIONS / PROCEDURES		HOURS					MECHANIC	
		25	50	100	200	ANN	RT	LT
	Baggage compartment covers and seals: inspect for condition, security, operation, excessive wear, and corrosion under nut-plates.	After inspection, coat latch mechanism with suitable anti-corrosion grease to protect per section 9.0 Servicing Instructions of this manual.		X				
	Pumper Tube Installation: inspect for condition, security, and routing of hoses.				X			
<b>Water Rudder System &amp; Tail</b>	Water rudder blades – inspect for cuts, tears and condition.	Water rudder blades and posts – inspect for damage, security of attachment, corrosion, paint, rigging. Check post bolts and bushings and lube with LPS 2.	X					
	Water rudder steering and retract systems – inspect the following: cables for broken wire; fittings for cable slippage, cracks and distortion; cable pulleys for freedom of rotation and cable guard pins for presence; rigging.	Check top and bottom rollers for rotation and lube with LPS 2 or similar product. Tension cables 30 lbs. +/- 5lbs.		X				
	On the aircraft: Remove, clean, inspect, and grease the Aux. finlets on the horizontal stabilizer.	Remove, clean, inspect and grease the strakes on the leading edge of the horizontal stabilizer.						X
<b>Electrical System</b>	Pump and indicator light wiring – inspect for chafing, broken, or loose terminals and general condition.			X				
	Pressure Switches – inspect wiring, mounting, and general condition.			X				X
	Pump Motors – inspect wiring, mounting, and general condition.			X				X

INSTRUCTIONS / PROCEDURES		HOURS					MECHANIC	
		25	50	100	200	ANN	RT	LT
	Emergency Trim Timer Override System (ETTOS) – inspect wiring and function	Activate system and insure that the aileron trim tab moves continuously left and right when trim timer bypass is active; and that when the system is inactive the aileron trim tab moves for 1 second and then stops until the button is released and depressed again.		X			X	
<b>Landing Gear Systems</b>	Inspection and servicing nose gear tracks:	Nose tracks and blocks – clean and dry or clean and wipe with silicone spray.	X				X	
	Nose Gear Box/Block Tracks measured at slide route for wear .050” or less wear tolerance.	Check side play – 3/32” to 1/8” max tolerance.			X		X	
	Nose gear pivot blocks and forks – inspect for condition, lubrication, corrosion, and paint.		X				X	
	Nose & Main wheel bearings – Grease Zerks.		X				X	
	Inspect Hydraulic rotary actuator in the main wheel well.		X				X	
	Hydraulic fluid level : MIL-H-5606	Check indicators on tanks. Fill as needed				X	X	
	Wheels and tires – inspect for wear, pressure, and condition.	Main Wheels: 50 psi ± 5 psi. Nose Wheels: 60 psi ± 5 psi.				X	X	
	Brake assemblies – inspect for wear, corrosion, and leakage.					X	X	
	Hydraulic fluid in reservoir should be checked for moisture or other contaminants and changed if necessary.	When the plastic reservoir is removed, the visible screens should be inspected and cleaned before reassembly.					X	

INSTRUCTIONS / PROCEDURES		HOURS					MECHANIC			
		25	50	100	200	ANN	RT	LT		
	Main and Nose gear actuators, Assemblies - inspect for condition, lubrication, leakage, corrosion, and cleanliness.			X				X		
	Nose gear springs - Scotchply springs, inspect for cracks, delamination and paint.			X				X		
	Main gear drag link bushings - inspect for condition, lubrication, and corrosion.			X				X		
	Clean the wheel wells to facilitate general condition inspection.			X				X		
	Main gear oleos - inspect for evidence of leakage, proper extension, and check cylinder for corrosion, pitting, cleanliness, and security.			X				X		
	Inspect the inside of the Main Landing Gear Axle Shaft for corrosion.							X		
	Hydraulic lines and fittings - inspect for leaks, condition, and security.						X	X		
	Hydraulic Manifolds (if Equipped) – inspect for condition, security, and leaks.						X	X		
	Brake system plumbing - inspect for leaks, condition, and security.						X	X		
	Main gear oleos – Check for static compression, leaks and proper pressure. The oleo should be fully serviced, replaced, or overhauled as required at annual inspection.			X				X		
	If full servicing is required, use 5606 hydraulic fluid & Nitrogen. Cylinder PSI 275-325 Cylinder capacity 1153 ± 20ml.									

INSTRUCTIONS / PROCEDURES		HOURS					MECHANIC	
		25	50	100	200	ANN	RT	LT
	Perform retraction tests as follows:				X	X		
	1. Hoist aircraft and place on stands.							
	2. Turn on Aircraft Master switch.							
	3. Select Gear 'UP' position using selector.							
	4. Verify gear lights indicate gear positions correctly while gear is in transit and at the end of travel.							
	5. Select Gear 'DOWN' position using selector.							
	6. Verify gear lights indicate gear positions correctly while gear is in transit and at the end of travel.							
	Perform Emergency Gear Retractions/Extension tests as follows:				X	X		
	1. Pull gear pump circuit breakers (2)							
	2. Select desired gear position using Emergency Selector Valve.							
	3. Extend emergency hand pump handle and pump vertically until force increases noticeably (150+ strokes).							
	4. Verify gear lights indicate gear positions correctly while gear is in transit and at the end of travel.							
	5. Repeat in opposite direction.							

INSTRUCTIONS / PROCEDURES		HOURS					MECHANIC	
		25	50	100	200	ANN	RT	LT
	Nose and Main wheel bearings – disassemble and inspect	Re-grease bearings with suitable water resistant grease per section 9.0 servicing Instructions of this manual.		X				
<b>Engine Exhaust Ducts (when installed per 1004690)</b>	Inspect engine exhaust ducts and heat shield, if installed, for security of attachment and cracks or damage.	Clean soot & exhaust deposits for visual inspection. Ensure attachment hardware is tight (refer to torque chart). Note: Not all aircraft are equipped the waterline cut exhaust system. Wipaire recommends any repairs to the exhaust stacks be done by Frakes Aviation (Clerburne, Texas, USA). Repairs by other facilities for vendors will void the warranty provided by Frakes Aviation.		X			X	
<b>Elevator down-Spring (when installed per 1004690)</b>	Inspect the elevator down-spring for proper operation and security.	Inspect the attachment of the elevator down- spring clamp on the appropriate elevator control cable and on the fuselage attachment (on the autopilot clutch bracket). Fasteners should be secure.		X			X	

### 9.3 FLOAT REMOVAL AND RE-INSTALLATION GUIDE

<b>FLOAT KIT INSTALLATION ITEMS</b>			
(The following items are installed with the float kit, some items must be removed, some items must be left in place, and some may be optionally removed when the aircraft is taken off of floats.)			
Item	Remove	Leave	Optionally Remove
1. Horizontal Strakes	X		
2. Floats and Struts	X		
3. Auxiliary Fins (Finlets)	X		
4. Waterline Cut Exhaust System			X
5. Mounting Hardpoints installed in horizontal stabilizer for finlets		X	
6. Doublers on empennage and horizontal stabilizer for strake mounting		X	
7. Hardpoints installed in tailcone for hydraulic pump mounting		X	
8. Elevator Trim Tab Extension		X	
9. Vertical Stabilizer VG Array		X	
10. Forward strut attachment fittings on firewall		X	
11. Hand operated emergency hydraulic pump and water rudder retract handle			X
12. Landing Gear Selector			X
13. Hydraulic Power Pack (located in tailcone)			X
14. Emergency Trim Timer Override System (ETTOS)			X

**Note:** G1000 Software - Reference Wipaire drawing 1002632 note 6. This is appropriate for landplane or floatplane.

**Note:** If floats are installed or removed for the first time, reweigh aircraft.

**FIGURE 9-1 FLOAT KIT INSTALLATION ITEMS**

FLOAT REMOVAL INSTRUCTIONS / PROCEDURES	MECH RIGHT	MECH LEFT	INSP.
<p>This is intended as a general guide. Each installation may have subtle differences. Always use the installation drawings as the final reference. All work should be done by certified aircraft technicians.</p>			
1. Connect the lifting bar to the hoist and position aircraft underneath			
2. Remove wing root fairings			
3. Inspect aircraft hoist points under wing root fairings for proper security before hoisting as per Quest Kodiak hoisting instructions.			
4. Attach ropes and ballast to tie-down rings as required to keep aircraft level while lifting.			
5. Lower aircraft so wheels just touch and relieve hydraulic pressure before pulling pump circuit breakers. Install tie-wrap to shank for safety.			
6. Loosen rear flying wires and boxing wires			
7. Remove the following items from aircraft :			
Nose gear cover plate			
Lower nose cowlings			
Machining that secures steering bungee			
Pylon Fairings at main gear attach			
Auxiliary fins & strakes (cover holes with cover plates). Strake doubler holes can be filled with appropriately sized screws (see finlet/strake removal section for more detail).			
Bolts from forward struts			
Rear cargo struts and step assembly			
Auxiliary fins (cover holes with cover plates)			
Nuts from top bolts in forward struts			

FLOAT REMOVAL INSTRUCTIONS / PROCEDURES CONTINUED	MECH RIGHT	MECH LEFT	INSP.
This is intended as a general guide. Each installation may have subtle differences. Always use the installation drawings as the final reference. All work should be done by certified aircraft technicians.			
Bolts from front step struts.			
Bolts from front step struts			
Bolts from two pylon attach points			
Rear fly wire Nuts at aircraft attach			
Pilot and Co-pilot step covers (for landplane steps)			
Elevator down-spring and cable (if installed)			
Hydraulic lines at the front pylon fairing location and cap			
Electrical cannon plug in main wheel well			
Remove cables attaching to copilot's rudder pedals			
Retract cable (Secure in main gear well)			
Belly pulley brackets (install appropriately sized screws back into nut-plates)			
Brake lines and cap			
8. Lift aircraft and remove floats			
9. Lower aircraft to working height for access to main gear			
10. Remove main gear saddle clamps and remove the following:			
Main strut attach fittings			



<p align="center"><b>FLOAT REMOVAL INSTRUCTIONS / PROCEDURES CONTINUED</b></p> <p>This is intended as a general guide. Each installation may have subtle differences. Always use the installation drawings as the final reference. All work should be done by certified aircraft technicians.</p>															
Cross tubes in belly															
11. Install main gear back into aircraft															
12. Install nose gear and attach steering bungee (Re-rig Steering Bungee per Quest Kodiak Maintenance Manual).															
13. Refer to Quest Kodiak Maintenance Manual Section 32 for gear installation & removal procedures.															
14. Connect brake lines and bleed for air bubbles															
15. Install main gear fairings															
16. Install pilot and co-pilot step assemblies															
17. Install lower LT. & RT. cowling															
18. Install nose gear fairings															
19. Install all floor plates and carpet															
20. Install aft bulkhead															
21. Install any seats previously removed															
22. Remove aircraft from hoist & add air to tires as required															
23. Install wing-root fairings															
24. Check all placards to conform to landplane category															

FLOAT REMOVAL INSTRUCTIONS / PROCEDURES CONTINUED	MECH RIGHT	MECH LEFT	INSP.
<p>This is intended as a general guide. Each installation may have subtle differences. Always use the installation drawings as the final reference. All work should be done by certified aircraft technicians.</p> <p>25. Make logbook entry</p> <p><b>NOTES:</b></p>			

	MECH RIGHT	MECH LEFT	INSP.
<p align="center"><b>AUXILIARY FIN (FINLET), STRAKE, &amp; EXHAUST STACK REMOVAL</b></p> <p>This is intended as a general guide. Each installation may have subtle differences. Always use the installation drawings as the final reference. All work should be done by certified aircraft technicians.</p>			
<p><b>Finlet Removal (reference drawing 1004099)</b></p>			
<p>1. Remove screws near horizontal stabilizer on both the upper finlet and lower finlet (8 screws total, 4 forward, 4 aft)</p>			
<p>2. Slide lower finlet down to remove from horizontal</p>			
<p>3. Slide upper finlet up to remove from horizontal</p>			
<p>4. Unbolt attachment clips from forward upper, forward lower, aft upper, and aft lower attach points and remove from horizontal stabilizer</p>			
<p>5. Install forward upper, forward, lower, aft upper, and aft lower cover plates using AN525 pan head screws</p>			
<p>6. Place all loose parts in bag and zip tie to removed finlets</p>			
<p><b>Strake Removal (reference drawing 1004500)</b></p>			
<p>1. Unscrew all fasteners from strake mounting flanges (upper horizontal stab, lower horizontal stab, fuselage)</p>			
<p>2. Pull strake forward and outboard to remove from aircraft</p>			
<p>3. Install AN525 pan head screws in all attachment locations</p>			
<p>4. Place all loose parts and fasteners in bag and zip tie to removed strakes</p>			
<p><b>Waterline Cut Exhaust System Removal (reference drawing 1004690)</b></p>			
<p>1. Remove Waterline Cut Exhaust System (Wipaire PN's 1008398 and 1008399)</p>			
<p>2. Install Standard Quest Exhaust Ducts in accordance with Quest Service Letter SL-007 dated 5/06/09 or later revision (Quest PN's 100-178-1001 &amp; 100-178- 1002 or 100-178-1003 &amp; 100-178-1004)</p>			

	MECH RIGHT	MECH LEFT	INSP.
<p style="text-align: center;"><b>OPTIONALLY REMOVED FLOAT KIT ITEMS</b></p> <p>The following items may be removed when the aircraft is removed from floats, but it is recommended for ease of float reinstallation that they are left in place.</p> <p>This is intended as a general guide. Each installation may have subtle differences. Always use the installation drawings as the final reference. All work should be done by certified aircraft technicians.</p>			
<p><b>Hydraulic Power Pack (in tailcone)</b></p>			
<p>1. Disconnect, cap, and secure hydraulic lines that run forward under the floor (3 lines)</p>			
<p>2. Disconnect and secure electrical power lines and gear position connector from power pack</p>			
<p>3. Unbolt power pack mounting plate from installed hardpoints and remove</p>			
<p>4. Pull and secure electric motor breakers on fwd breaker panel</p>			
<p><b>Hand Operated Emergency Hydraulic Pump and Water Rudder Retract Handle</b></p>			
<p>1. Unbolt Pedestal from floor</p>			
<p>2. Disconnect, cap, and secure hydraulic lines under the floor (3 lines)</p>			
<p>3. Disconnect water rudder retract cable, coil, and secure under floor</p>			
<p>4. Install appropriately sized bolts in pedestal attachment locations</p>			
<p><b>Gear Selector</b></p>			
<p>1. Unscrew selector face and remove from panel</p>			

	MECH RIGHT	MECH LEFT	INSP.
<p style="text-align: center;"><b>OPTIONALLY REMOVED FLOAT KIT ITEMS</b></p> <p>The following items may be removed when the aircraft is removed from floats, but it is recommended for ease of float reinstallation that they are left in place.</p> <p>This is intended as a general guide. Each installation may have subtle differences. Always use the installation drawings as the final reference. All work should be done by certified aircraft technicians.</p>			
2. Disconnect gear position connector and secure behind panel			
3. Install Filler plate in panel			
<b>Emergency Trim Timer Override System (ETTOS)</b>			
1. Remove Guarded Switch from panel			
2. Follow wires from override switch to trim timer connection			
3. Unplug override switch connectors and reconnect trim timer using existing connectors			
4. Plug Hole in panel left from override switch			
5. Remove "Emergency Aileron Trim Timer Bypass" Placard			

<b>FLOAT RE-INSTALL INSTRUCTIONS / PROCEDURES</b>	<b>MECH RIGHT</b>	<b>MECH LEFT</b>	<b>INSP.</b>
<p>This is intended as a general guide. Each installation may have subtle differences. Always use the installation drawings as the final reference. All work should be done by certified aircraft technicians.</p> <ol style="list-style-type: none"> <li>1. Remove the nose and main gear fairings.</li> <li>2. Remove wing root fairings</li> <li>3. Install finlets &amp; strakes and seal</li> <li>4. Remove pilot and co-pilot steps</li> <li>5. Disconnect brake lines and cap</li> <li>6. Cut tie-wrap from pump circuit breakers</li> <li>7. Tie ropes from tie-down rings. Connect lifting rig to hoist and inspect aircraft lifting points at wing root for proper assembly before connecting to aircraft. Use ballast from tie-down ropes to ensure level lifting.</li> <li>8. Raise aircraft until wheels are just touching the ground and assemble crew (minimum 6 people) for installation</li> <li>9. Remove main gear per Kodiak Maintenance Manual section 32</li> <li>10. Install cross tubes in belly. Caution, take care not to crush/cut brake or gear hydraulic lines</li> <li>11. Install main pylon attach fitting into gear saddles and pin to cross tubes</li> <li>12. Torque saddle bolts to 40 ft-lbs</li> <li>13. Lower aircraft to floats, install front struts first then lower aircraft onto pylon attach fitting and install bolts</li> <li>14. Remove the nose gear</li> <li>15. Install rear flying wires, rig with regard to airflow</li> <li>16. Install boxing wires</li> </ol>			

FLOAT RE-INSTALL INSTRUCTIONS / PROCEDURES CONTINUED	MECH RIGHT	MECH LEFT	INSP.
<p>This is intended as a general guide. Each installation may have subtle differences. Always use the installation drawings as the final reference. All work should be done by certified aircraft technicians.</p> <p>17. Secure the steering bungee &amp; connect the hydraulic lines (Re-rig Steering Bungee per Quest Kodiak Maintenance Manual)</p>			
18. Locate jack stands under floats			
19. Perform gear check & ensure all lights agree with gear and gear advisory			
20. Cycle time up: 45 seconds - check for leaks			
21. Cycle time down: 45 seconds - check for leaks			
22. Hand pump the gear down and up and check for leaks again			
23. Route and rig the steering cables & water rudder retract cables (30lbs +/- 5)			
24. Functionally check water rudder rigging, with water rudders down, as follows:			
-Move air rudder to the right, confirm water rudder moves to the right			
-Move air rudder to the left, confirm water rudder moves to the left			
-Insure system moves freely in both directions with no catching or binding			
25. Install step struts			
26. Install brake lines and bleed for air bubbles			
27. Install elevator down-spring (if required by exhaust configuration)			
28. Install fairings for main pylon, nose gear cover panel, and wing root fairings			
29. Inflate main gear tires to 60 lbs +/- 5 lbs, nose tires to 60 lbs +/- 5 lbs			

<p align="center"><b>FLOAT RE-INSTALL INSTRUCTIONS / PROCEDURES CONTINUED</b></p> <p>This is intended as a general guide. Each installation may have subtle differences. Always use the installation drawings as the final reference. All work should be done by certified aircraft technicians.</p>				
		MECH RIGHT	MECH LEFT	INSP.
30. Remove aircraft from stands. Check for proper main oleo extension (>3" of chrome should be visible at static deflection)				
31. Check aircraft placards against the drawings for accuracy				
32. Install cover over pilot and co-pilot step holes.				
33. Make logbook entry & check for proper placarding.				

**Note:** Reference Float Kit Installation checklist at the beginning on Section 9.3.



## 9.4 WEIGHING PROCEDURES FOR QUEST KODIAK ON WIPAIRE 7000 AMPHIBIAN FLOATS

Level aircraft per the manufacturer's instructions.

Place scales under the right and left main and nose gears.

Place blocking under the right and left main gears to level aircraft.

Draw lines on the floor from the centerline main wheels and centerline nose wheel left to right.

Drop a plumb bob from the face of the firewall. This is station 0.0.

Draw another line between the nose wheel centers and a 4th line between the main wheel centers.

Measure the distance from 0.0 to the nose wheel line. This is X1 and X2.

Measure the distance from 0.0 to the main wheel line. This is Y1 and Y2.

Scale Reading	Distance from 0.0	Weight x Arm	Weight
Left Front	+ X1	+	
Right Front	+ X2	+	
Left Rear	+ Y1	+	
Right Rear	+ Y2	+	

Totals

**Notes:**

1. Zero out or deduct tare weights at the Y arm.

## 9.5 WIPAIRE FLOATS SPECIAL TOOLS

1. 1004800 Main Gear Rigging tool referred to in Chapter 4 is a tool that will be given to customers as part of the float purchase. If it gets lost or broken, a replacement can be purchased by contacting Wipaire Customer Service.
2. The tow bar mentioned in Chapter 1 is available in several models. Contact Wipaire Customer Service for details.
3. The lifting rig also mentioned in Chapter 1 is also available for purchase. Contact Wipaire Customer Service for details.

## CHAPTER 10 TROUBLESHOOTING

### CONTENTS

10.0 TROUBLESHOOTING GUIDE .....	92
----------------------------------	----

## 10.0 TROUBLESHOOTING GUIDE

Malfunction	Potential Cause(s)	Corrective Action
Power pack does not run after gear selection.	a. Circuit breaker is open (triggered).	a. Reset circuit breaker
	b. Pressure switch is not actuating at the low pressure trip point.	b. Jump across pressure switch leads to determine if motor runs. If motor operates replace the solenoid switch.
	c. Solenoid switch not actuating.	c. Jump across solenoid leads and determine if motor runs. If motor operates replace solenoid pressure switch.
	d. Faulty ground on pump.	d. Correct motor ground.
	e. Faulty pump motor.	e. Replace faulty pump motor.
Power pack does not shut down after gear reached desired position.	a. Faulty pressure switch.	a. Replace pressure switch.
	b. Faulty or dirty pressure relief valve allowing insufficient pressure to satisfy switch.	b. Clean or replace relief valve as required.
Power pack shuts off before gear reaches desired position.	a. Binding or jammed gear .retractor	a. Repair gear retractor.
	b. Faulty pressure relief valve.	b. Replace faulty pressure relief valve.
Power pack cycles on and off after gear is in position.	a. External hydraulic leak.	a. Visually inspect lines, actuators and hoses and replace as required.
	b. Internal hydraulic leak.	b. Disconnect and cap off on actuator at a time and isolate the internally leaking actuator by process of elimination. If all the actuators have been isolated and the pump cycling continues, replace the power pack check valve.
Power pack cycles on and off during gear cycle.	a. Binding in the retraction unit.	a. Inspect for free operation of the retraction unit. Suspect the gear that retracts last.
	b. Pressure switch cut off limit too low.	b. Replace pressure switch.

Malfunction	Potential Cause(s)	Corrective Action
Slow gear retraction (considerably longer than 30 seconds).	<ul style="list-style-type: none"> <li>a. Plugged oil screen.</li> <li>b. Poor electrical connection to motor.</li> <li>c. Poor motor.</li> <li>d. Worn pump gears.</li> </ul>	<ul style="list-style-type: none"> <li>a. Clean intake screen located inside reservoir tank.</li> <li>b. Connect a 24 VDC power source directly to the pump. If pump operation improves correct wiring.</li> <li>c. Replace pump motor.</li> <li>d. Replace pump.</li> </ul>
Circuit breaker pops during cycle.	<ul style="list-style-type: none"> <li>a. Defective or corroded wire connections.</li> <li>b. Defective motor brushes.</li> <li>c. Defective circuit breaker.</li> </ul>	<ul style="list-style-type: none"> <li>a. Correct wiring and protect terminals with grease.</li> <li>b. Replace pump motor.</li> <li>c. Replace circuit breaker.</li> </ul>
Landing gear position indicators do not test.	<ul style="list-style-type: none"> <li>a. Landing gear indication circuit breaker tripped.</li> <li>b. Annunciator test switch defective.</li> </ul>	<ul style="list-style-type: none"> <li>a. Reset circuit breaker.</li> <li>b. Replace annunciator test switch.</li> </ul>
Individual landing gear position indicator does not test	<ul style="list-style-type: none"> <li>a. Defective bulb</li> </ul>	<ul style="list-style-type: none"> <li>a. Replace defective bulb.</li> </ul>
Individual landing gear position indicator illuminates during test, but does not show correct gear position	<ul style="list-style-type: none"> <li>a. Gear out of position and not contacting gear position switch</li> <li>b. Defective gear position switch.</li> </ul>	<ul style="list-style-type: none"> <li>a. Using extreme caution inspect affected gear to determine that the gear is fully in the selected position. Correct gear actuation condition.</li> <li>b. Replace defective gear position switch.</li> </ul>
Aircraft leans to one side on amphibian gear.	<ul style="list-style-type: none"> <li>a. Fuel has migrated from one wing to the other causing a fuel imbalance.</li> <li>b. Tires not inflated properly.</li> <li>c. Oleo strut may be underserviced.</li> </ul>	<ul style="list-style-type: none"> <li>a. Check fuel level in both wings for correct fuel balance and transfer fuel as necessary to bring fuel into balance.</li> <li>b. Inflate tires to correct pressures</li> <li>c. Service strut as required.</li> </ul>

Malfunction	Potential Cause(s)	Corrective Action
	d. Damaged gear parts or bent axle.	d. Inspect gear for loose or damaged parts including a bent axle and repair as required
Aircraft leans to one side on floats in water	<ul style="list-style-type: none"> <li>a. Fuel has migrated from one wing to the other causing a fuel imbalance</li> <li>b. A float has a large quantity of water in it</li> </ul>	<ul style="list-style-type: none"> <li>a. Check fuel level in both wings for correct fuel. Fuel as necessary to bring fuel into balance.</li> <li>b. Check floats for water and evacuate water as required. Inspect floats for leaks in structure or around access panels and correct as required.</li> </ul>
Tires wear excessively – Main gear	<ul style="list-style-type: none"> <li>a. Tires not inflated to proper pressures.</li> <li>b. Main gear trucks out of alignment.</li> <li>c. Landing gear has loose or worn components.</li> <li>d. Axle is bent</li> <li>e. Brakes dragging.</li> <li>f. Wheel/tires out of balance.</li> </ul>	<ul style="list-style-type: none"> <li>a. Inflate tires to correct pressures.</li> <li>b. Align left and right float using horizontal cross wires.</li> <li>c. Replace or adjust landing gear components.</li> <li>d. Replace landing gear lower link.</li> <li>e. Inspect and repair brake components to preclude brake drag.</li> <li>f. Balance wheels/tires as required.</li> </ul>
Tires wear excessively – nose gear	<ul style="list-style-type: none"> <li>a. Tires not inflated to proper pressures.</li> <li>b. Landing gear has loose or worn components.</li> <li>c. Axle is bent</li> <li>d. Wheel/tires out of balance.</li> </ul>	<ul style="list-style-type: none"> <li>a. Inflate tires to correct pressures.</li> <li>b. Replace or adjust landing gear components.</li> <li>c. Replace nose gear yoke/axle assembly</li> <li>d. Balance wheels/tires as required.</li> </ul>
Wheel and tire vibration	a. Wheel/tire out of balance	a. Balance wheels and tires.
Nose wheel shimmies	a. Loose or worn nose gear components.	a. Inspect nose gear components for condition and wear. Adjust or replace components as required.

Malfunction	Potential Cause(s)	Corrective Action
	b. Nose wheel/tires out of balance.	b. Balance nose wheel/tire
Brakes drag	a. Binding brake pedals.	a. Lubricate the brake pedal pivot points or repair/replace defective parts.
	b. Broken brake piston return spring.	b. Repair or replace brake master cylinder.
	c. Improperly rigged parking brake control.	c. Re-rig parking brake control.
	d. Restriction in brake hydraulic lines.	d. Remove restriction from lines, flush system and reservoir with clean hydraulic fluid.
	e. Warped or scored brake disk.	e. Replace disc and linings.
	f. Brake damage or accumulated dirt and grim restricting movement.	f. Clean or replace components as required.
Brakes fail to operate	a. Improper brake hydraulic fluid level.	a. Service brake hydraulic reservoir.
	b. Worn brake linings.	b. Replace brake linings.
	c. Defective O-ring in master or brake cylinder.	c. Replace defective O-ring.
	d. Internal damage due to incorrect type of brake fluid in system.	d. Replace or rebuild defective components, flush system, refill system with MIL-H-5606, and bleed the brakes.
Brakes feel spongy.	a. Air in brake system.	a. Bleed brakes.
	b. Swollen or defective hoses.	b. Replace defective hoses.
	c. Improper brake hydraulic fluid level.	c. Service brake hydraulic reservoir.
Water rudders fail to retract and extend normally.	a. Water rudder cable system out of rig or binding.	a. Inspect water rudder cable system for condition and rigging. Correct as required.
Water rudders fail to retract to the same height	a. Water rudder retract cable system out of rig.	a. Rig water rudder cable system.
	b. Broken or mis-adjusted water rudder up stop.	b. Replace and adjust water rudder up stops.
Water rudders fail to operate.	a. Water rudder system cable broken.	a. Replace defective water rudder cable.

Malfunction	Potential Cause(s)	Corrective Action
	b. Water rudder cable system out of rig.	b. Rig water rudder cable system.
Aileron trim fails to operate continuously when in timer override (ETTOS).	a. Defective timer override switch	a. Replace timer override switch
	b. Defective aileron trim switch	b. Replace aileron trim switch
	c. Defective trim system wiring	c. Correct system wiring
	d. Defective aileron trim actuator	d. Check for 1 second trim operation with the override switch in the normal position. Replace aileron trim actuator if there is no trim movements in the normal position.



## CHAPTER 11 INSTALLATION PRINT INFORMATION

### CONTENTS

11.0 WIPAIRE DRAWINGS REQUIRED FOR 7000 FLOAT INSTALLATION.....	98
---	----

## 11.0 WIPAIRE DRAWINGS REQUIRED FOR 7000 FLOAT INSTALLATION

1004099	INSTALL FINLETS
1004211	INSTALL STEERING & RETRACT SYSTEM
1004469	INSTALL HYDRAULIC SYSTEM / WIRE ROUTING
1004472	WIRING SCHEMATIC
1004500	INSTALL STRAKES
1004527	INSTALL VORTEX GENERATORS, TRIM TAB EXTENSIONS
1004651	INSTALL FWD. STRUTS & PYLONS, STANDARD CONFIGURATION
1004652	STRUT INSTALLATION, HS, KODIAK 100 (OPTIONAL)
1004653	INSTALL PILOT / COPILOT STEPS
1004690	INSTALL EXHAUST STACK MODIFICATION & ELEVATOR DOWNSPRING
1004693	INSTALL MISC. FUSELAGE ITEMS (FAIRINGS & COVERS)
1004973	INSTALLATION, FUEL HANDLES (OPTIONAL)
1004976	INSTALLATION, ANTENNA (OPTIONAL)
1005260	INSTALLATION, 3-BLADE 102" PROPELLER (OPTIONAL)
1006721	INSTALLATION, HINGED WINDOW, KODIAK (OPTIONAL)

# APPENDIX

## CONTENTS

APPENDIX A OPTIONAL YAGI ANTENNAS .....100

## APPENDIX A OPTIONAL YAGI ANTENNAS

### INTRODUCTION

Select serial numbers of the Kodiak 7000 amphibian may be optionally equipped with wing-strut mounted Yagi antennas for the purpose of wildlife tracking. The antennas are approved only when the aircraft is equipped with floats, and does not apply to the wheel equipped aircraft. The installation includes a padded cuff that bolts around the wing lift strut with a mount for a boom that the antenna is attached to. Specific data related to the limitations and performance of the aircraft with the antennas installed can be found in AFMS Doc. No. W7001-25-01, latest revision. Note: Antennas are certified for specific serial number aircraft and are equipped on a mission-specific basis.

### REMOVAL AND INSTALLATION

Loosen bolts and remove antenna boom (See Figure A-2). Remove three AN3 bolts at the trailing edge of the cuff to unclamp cuff from wing strut. Installation is reverse of removal, refer to Wipaire drawing 1004976.

### MAINTENANCE

#### Every 100 hours and at Annual:

Inspection of Wing Strut Mounted Antennas: Inspect wing strut cuff and antennas for secure attachment. Inspect all hardware for cracks and damage. Ensure pad is in place and cuff is securely attached to the wing strut and all fasteners are tight.

### WIPIRE DRAWINGS REQUIRED FOR INSTALLATION

1004976 - INSTALLATION, STRUT ANTENNA CUFF, KODIAK



**FIGURE A-1 YAGI ANTENNAS INSTALLED**



**FIGURE A-2: CUFF REMOVAL**