

# WIPLINE FLOATS

## MODEL 2100

### PARTS MANUAL



## CESSNA 172

THIS PAGE INTENTIONALLY LEFT BLANK

## TABLE OF CONTENTS

<u>SECTION</u>	<u>PAGE</u>
TABLE OF CONTENTS.....	3
LOG OF REVISIONS .....	4
FLOAT PART SALES DEPT. OPERATIONS .....	5
PARTS ORDERING .....	5
DAMAGED GOODS .....	5
RETURNED PARTS.....	5
ORDER SHORTAGES .....	6
CREDIT POLICY.....	6
LIST OF ABBREVIATIONS.....	6
NEW CUSTOMER INFORMATION.....	7
HULL ASSEMBLY – AMPHIBIAN.....	9
HULL ASSEMBLY – SEAPLANE .....	15
TOP SKIN – HULL – AMPHIBIAN .....	21
TOP SKIN – HULL – SEAPLANE .....	25
WHEELWELL ASSEMBLY – AMPHIBIAN .....	29
EXTRUSIONS – HULL – ASSEMBLY.....	31
EXTRUSIONS – HULL – SEAPLANE.....	33
PUMPER TUBE INSTALLATION.....	35
INSTALLATION WATER RUDDER.....	37
ASSEMBLY – NOSE GEAR RETRACTION.....	41
ASSEMBLY – NOSE GEAR – LOWER.....	45
ASSEMBLY – NOSE WHEEL (GROVE) .....	47
ASSEMBLY – NOSE WHEEL (PARKER) .....	49
INSTALLATION – MAIN GEAR RETRACTION.....	51
ASSEMBLY – MAIN GEAR WHEEL GROVE/WIPAIRE .....	55
ASSEMBLY – MAIN GEAR WHEEL CLEVELAND/PARKER .....	59
INSTALLATION – STRUTS, WIRES AND SPREADER BARS .....	63
INSTALLATION – FUSELAGE STEPS .....	67
ASSEMBLY – RETRACT HANDLE.....	69
INSTALLATION – STEERING AND RETRACT SYSTEM .....	71
INSTALLATION – HYDRAULIC SYSTEM.....	75
ASSEMBLY – HYDRAULIC PUMP.....	79
HYDRAULIC SCHEMATIC.....	83
ELECTRICAL SCHEMATIC.....	85
GEAR CONTROL (ROUND).....	87
GEAR CONTROL (RECTANGLE) .....	89
HYDRAULIC PUMP.....	91

### NOTE:

**Any information not found in this manual for strut package parts and other aircraft installation items refer to the installation drawing package provided with the STC at the time of float installation. Additional drawing copies are available for purchase through the Wipaire Customer Service department.**

Wipline Model 2100 Parts Manual

**LOG OF REVISIONS**

Revision	Pages Effected	Description	Date
A	55-59	ADDED NEW BRAKE ASSEMBLY & SHIFTED TABLE OF CONTENTS	12/12/05
B	44, 52	MAIN AND NOSE GEAR CYLINDER RETRACT P/N CHANGE.	3/20/06
C	20-26	Changed P/Ns for float deck covers.	8/3/06
D	51 ALL 62 63	Changed P/Ns for Main Gear Bushings Added part number and revision to all pages Ref 4- Drag Wire 1002111 was 21A02000-136 Ref 10 Wire Pull 21A02462-005 was 21A02519-008	10/31/06
E	44, 51	Hydraulic Cylinder part number change.	7/21/07
F	Multiple pages updated	Many pages changed with updated part numbers for parts. New figure added for water rudder.	9/1/10
G	ALL	Reformatted entire manual, update to Part Sales Dept page, added new warranty and customer information, updated hyd. pump, gear selector, strut, step, steering/retract, wires and spreader bar, electrical schematic images and BOMS, corrected multiple clerical errors and incorrect part/item callouts, added Grove Nose wheel, washer 415067 was 359071	5/28/2013
H	3	Removed Warranty Claim Form	3/31/16

You may also look at the latest parts manual at [www.wipaire.com](http://www.wipaire.com).  
Hours: 7:00 AM – 6:00 PM, Monday through Friday

## **FLOAT PART SALES DEPT. OPERATIONS**

Hours: 7:00 AM – 6:00 PM, Monday through Friday  
Central U.S. Time

Phone: 651-306-0459

Fax: 651-306-0666

Email: [customerservice@wipaire.com](mailto:customerservice@wipaire.com)

Website: [www.wipaire.com](http://www.wipaire.com)

### **Shipping Schedule:**

In-stock orders received before 3:00 PM CST ship the same day. Orders received after this time may be assessed an AOG fee for special priority handling.

As we are primarily a manufacturer, our stocks can be rapidly depleted by production requirements. Therefore, prices and availability are subject to change at any time. It is our intent to provide courteous and prompt service of your needs. Please let us know of any problem or concerns so that changes in these procedures can be a benefit to all.

## ***PARTS ORDERING***

Purchase orders should include

1. P.O. Number
2. Name of person placing order
3. Invoicing information:
  - I. Customer name – company or individual
    - i. Address
    - ii. Phone and fax number
4. Shipping information:
  - I. Address (if different from invoice address)
  - II. Method of shipment/preferred carrier
5. Aircraft model, float model and serial numbers
6. Wipaire part number; name; type, e.g. left or right; quantity
7. Payment method: VIS A, MasterCard, COD (U.S. customers only). Pre-payment by check or wire transfer, open account (see credit policy section).

## ***DAMAGED GOODS***

Inspect all parts upon receipt. Damages to parts in transit must be filed as a claim against the carrier.

## ***RETURNED PARTS***

Written explanation of reason for return must accompany parts, including invoice number of original shipment. Shipping charges on returned parts must be prepaid or the shipment will be refused.

## **ORDER SHORTAGES**

Check shipment against delivery slip immediately. All claims for any shortages should be made within three (3) days after order receipt.

## **CREDIT POLICY**

Parts will be shipped on open account, net 30 days, to Wipaire-approved credit customers only. A balance due over 60 days will result in no shipments. Wipaire, Inc reserves the right to send any order C.O.D.

## **LIST OF ABBREVIATIONS**

All references in this manual to LEFT and RIG HT are from the perspective of the pilot's seat with the floats fully installed and ready for floatplane operation. The following is a list of abbreviations that may appear in the description nomenclature fields of this manual:

AB	Afterbody	Inbd.	Inboard
Amphib.	Amphibious	Lg.	Large.
AR	As Required	Lt.	Left
Assy.	Assembly	Lwr.	Lower
Brkt.	Bracket	Opt.	Optional
Btm.	Bottom	Otbd.	Outboard
Bulk.	Bulkhead	Reinf.	Reinforcement
Ctr.	Center	Rr.	Rear
Cyl.	Cylinder	Rt.	Right
Ft.	Front	Sm.	Small
Ftg.	Fitting	SN	Serial Number
Fus.	Fuselage	Spr.	Spreader
Fwd.	Forward	Upr.	Upper
Horiz.	Horizontal	Vert.	Vertical
Hyd.	Hydraulic	W.W.	Wheel Well



## NEW CUSTOMER INFORMATION

<b>Customer Name</b>	
<b>Billing Address</b>	
<b>Shipping Address</b>	
Phone Number	Fax Number
<b>Purchasing Contact</b>	Phone Number
E-Mail	Fax Number
<b>Accounts Payable Contact</b>	Phone Number
E-Mail	Fax Number
Type(s) of Aircraft Owned or Maintained	
Model(s) of Floats and Skis Owned or Maintained	
FedEx and/or UPS account number (if applicable)	

Please return to Wipaire Customer Service:

Fax 651-306-0666

Phone 651-306-0459

[CustomerService@wipaire.com](mailto:CustomerService@wipaire.com)

THIS PAGE INTENTIONALLY LEFT BLANK



WIPLINE MODEL 2100 FLOAT PARTS MANUAL

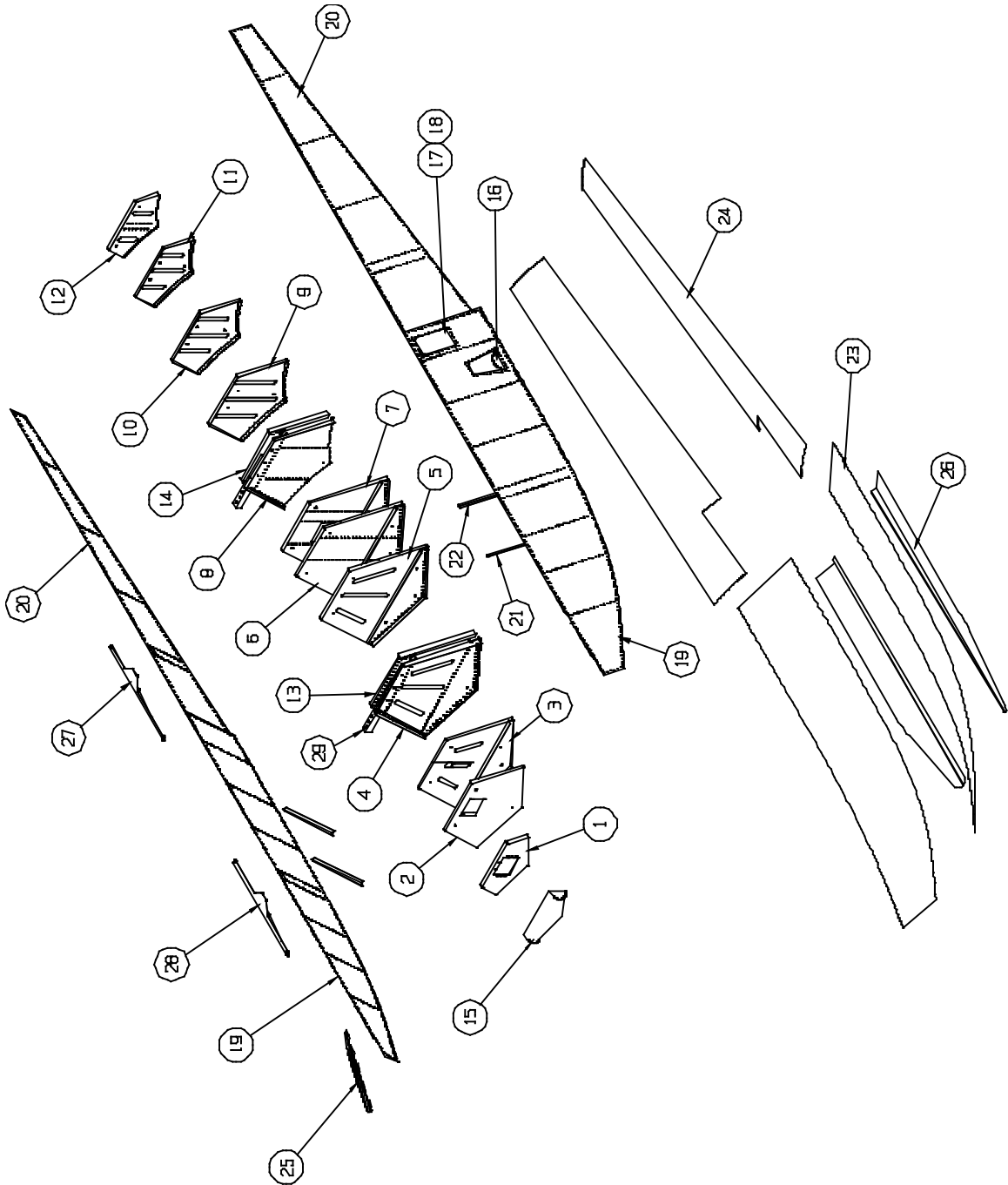

HULL ASSEMBLY – AMPHIBIAN  
FIGURE 1

WIPLINE MODEL 2100 FLOAT PARTS MANUAL

HULL ASSEMBLY - AMPHIBIAN, FIGURE 1

<u>REF NO.</u>	<u>NO.</u>	<u>REQ.</u>	<u>PART DESCRIPTION</u>	<u>PART NO.</u>
1	1		BULKHEAD #1	21A01163-067
2	1		ASSY BULKHEAD #3	21A01000-265
	1		BULKHEAD	21A01158-184
	1		ANGLE – NOSE BOX ATTACH	21A01326-006
	1		ANGLE – NOSE BOX ATTACH	21A01326-005
3	1		ASSY BULKHEAD #4	21A01000-261
	1		BULKHEAD – MAIN	21A01158-174
	1		SUPPORT – BULKHEAD LOWER	21A01158-175
	1		CLAMP, PUMP OUT TUBE	3A01158-003
4	1		ASSY BULKHEAD #5	21A01000-253
	1		BULKHEAD - MAIN	21A01158-178
	1		ANGLE – SIDE L.	21A01326-007
	1		ANGLE – SIDE R.	21A01326-008
	1		PANEL – SPR. BAR	21A01163-066
	1		SUPPORT – BULKHEAD #6	21A01158-177
	1		CLAMP, PUMP OUT TUBE	3A01158-003
5	1		ASSY BULKHEAD #6	21A01000-252
	1		BULKHEAD – MAIN	21A01158-189
	1		SUPPORT – BULKHEAD LOWER	21A01158-177
	1		GROMMET	MS35489-19
6	1		ASSY BULKHEAD #7 L.	21A01000-267
	1		BULKHEAD - MAIN	21A01158-181
	1		SUPPORT – BULKHEAD LOWER	21A01158-187
	1		ASSY BULKHEAD #7 R	21A01000-266
	1		BULKHEAD - MAIN	21A01158-182
	1		SUPPORT – BULKHEAD LOWER	21A01158-188
7	1		ASSY BULKHEAD #8 L.	21A01000-263
	1		BULKHEAD - MAIN	21A01158-191
	1		SUPPORT – BULKHEAD LOWER	21A01158-193

## WIPLINE MODEL 2100 FLOAT PARTS MANUAL

## HULL ASSEMBLY - AMPHIBIAN, FIGURE 1

<u>REF NO.</u>	<u>NO.</u>	<u>REQ.</u>	<u>PART DESCRIPTION</u>	<u>PART NO.</u>
	1		ANGLE – A.B. SKIN ATTACH L.	21A01158-179
	1		ANGLE – A.B. SKIN ATTACH R.	21A01158-180
	1		ASSY BULKHEAD #8 R	21A01000-264
	1		BULKHEAD - MAIN	21A01158-190
	1		SUPPORT – BULKHEAD LOWER	21A01158-192
	1		ANGLE – A.B. SKIN ATTACH L.	21A01158-179
	1		ANGLE – A.B. SKIN ATTACH R.	21A01158-180
8	1		ASSY. – BULKHEAD #10	21A01000-262
	1		BULKHEAD - MAIN	21A01158-169
	1		ANGLE SIDE L.	21A01326-011
	1		ANGLE SIDE R.	21A01326-012
	1		PANEL – SPR. BAR	21A01163-066
9	1		BULKHEAD #11	21A01000-395
10	1		BULKHEAD #12	21A01000-396
11	1		BULKHEAD #13	21A01000-397
12	1		ASSY. BULKHEAD #14	21A01000-250
	1		BULKHEAD - MAIN	21A01158-164
	1		CHANNEL – REIN.	21A01158-165
	1		PLATE – WATER RUDDER STOP	21A08156-130
13	1		ASSY. SPR. BAR PANEL FWD	21A01000-260
	1		PANEL – SPR. BAR	21A01163-065
	1		ANGLE – SIDE L.	21A01326-013
	1		ANGLE – SIDE R.	21A01326-014
	1		BOLT	AN4-5A
	1		WASHER	NAS1149F0463P
	1		NUT	MS21044N4
14	1		ASSY. SPR. BAR PANEL AFT	21A01000-259
	1		PANEL – SPR. BAR	21A01163-065
	1		ANGLE – SIDE L.	21A01326-009

## WIPLINE MODEL 2100 FLOAT PARTS MANUAL

## HULL ASSEMBLY - AMPHIBIAN, FIGURE 1

<u>REF NO.</u>	<u>NO. REQ.</u>	<u>PART DESCRIPTION</u>	<u>PART NO.</u>
	1	ANGLE – SIDE R.	21A01326-010
	1	BOLT	AN4-5A
	1	WASHER	NAS1149F0463P
	1	NUT	MS21044N4
15	1	NOSE BUMPER	21A01000-295
16	1	STEP – BOARDING	3A01000-005
17	2	REINFORCEMENT – COVER	21A01156-126
18	2	CONVER – INSP. ASSY.	21A01000-427
	2	COVER – INSP.	21A01004-101
	2	GASKET	21A01567-012
	56	SCREW – ATTACH	AN526-632R6
19	1	SIDE SKIN – STEP TO BOW L. OUTBR'D	21A01004-093
	1	SIDE SKIN – STEP TO BOW R. OUTBR'D	21A01004-094
	1	SIDE SKIN – STEP TO BOW L. INBR'D	21A01004-095
	1	SIDE SKIN – STEP TO BOW R. INBR'D	21A01004-096
	1	BRACKET (PADDLE)	1002114
	1	STOP (RIGHT)	1002113
	1	CLIP	3A01503-001
	1	PADDLE 4 FT.	0238-0035
20	1	SIDE SKIN – STEP TO STERN L. OUTBR'D	21A01004-097
	1	SIDE SKIN – STEP TO STERN R. OUTBR'D	21A01004-098
	1	SIDE SKIN – STEP TO STERN L. INBR'D	21A01004-099
	1	SIDE SKIN – STEP TO STERN R. INBR'D	21A01004-100
		<u>NOTE:</u> DIFFERENCE BETWEEN R. AND L. IS FINISH	
21	2	STIFFENER – SIDE SKIN	21A01340-105
22	2	STIFFENER – SIDE SKIN	21A01340-104
23	1	ASSY. BOTTOM SKIN FWD L.	21A01000-307

## WIPLINE MODEL 2100 FLOAT PARTS MANUAL

## HULL ASSEMBLY - AMPHIBIAN, FIGURE 1

<u>REF NO.</u>	<u>NO. REQ.</u>	<u>PART DESCRIPTION</u>	<u>PART NO.</u>
	1	SKIN ALONE	21A01005-265
	1	ASSY. BOTTOM SKIN FWD R.	21A01000-306
	1	SKIN ALONE (ASSY. INCLUDES BONDED STIFFENERS)	21A01005-265
	2	STIFFENER	21A01322-001
	2	STIFFENER	21A01322-002
	2	STIFFENER	21A01322-003
	2	STIFFENER	21A01322-004
	2	STIFFENER	21A01322-005
	6	STIFFENER	21A01322-006
24	1	BOTTOM SKIN AFTERBODY L.	21A01004-103
	1	BOTTOM SKIN AFTERBODY R.	21A01004-104
25	1	ASSY. SPRAY RAIL L.	21A01000-275
	1	ASSY. SPRAY RAIL R.	21A01000-274
26	1	BOOSTER – SISTER KEEL L.	21A01000-429
	1	BOOSTER – SISTER KEEL R.	21A01000-428
27	1	DOUBLER – GUNWALL AFT L.	21A01162-033
	1	DOUBLER – GUNWALL AFT R.	21A01162-034
28	1	DOUBLER – GUNWALL FWD L.	21A01162-031
	1	DOUBLER – GUNWALL FWD R.	21A01162-032
29	2	TUBE – SPR. BAR MOUNTING	21A03115-001
	6	BOLT	AN4-22A
	12	WASHER	NAS1149D0416J
	12	WASHER	NAS1149D0463J
	6	NUT	MS21044N4

THIS PAGE INTENTIONALLY LEFT BLANK

WIPLINE MODEL 2100 FLOAT PARTS MANUAL

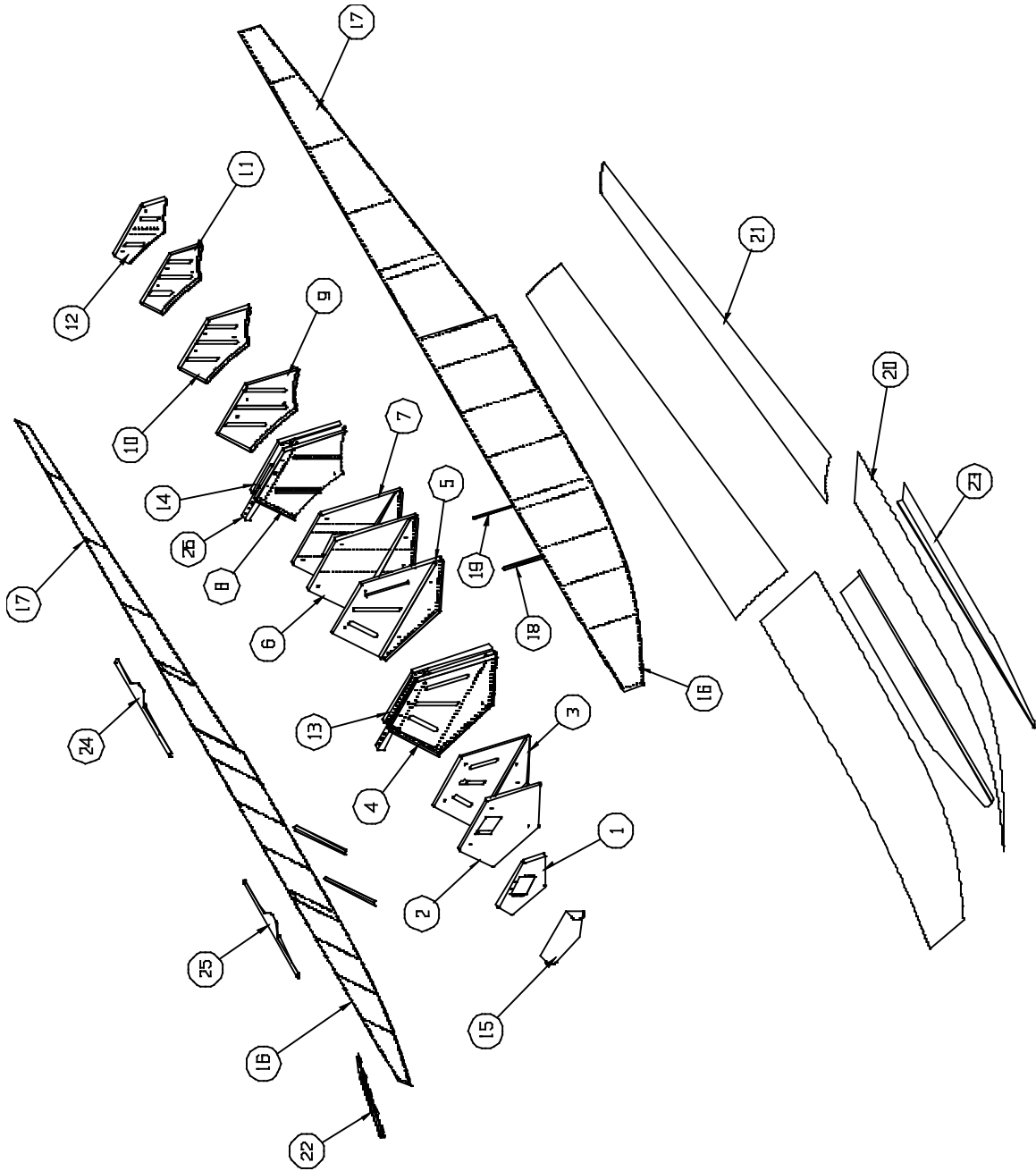

HULL ASSEMBLY – SEAPLANE  
FIGURE 2

WIPLINE MODEL 2100 FLOAT PARTS MANUAL

HULL ASSEMBLY - SEAPLANE, FIGURE 2

<u>REF NO.</u>	<u>NO.</u>	<u>REQ.</u>	<u>PART DESCRIPTION</u>	<u>PART NO.</u>
1	1		BULKHEAD #1	21A01163-067
	1		COVER ASS'Y	21501000-366
	1		COVER – NOSE GEAR OPENING	21S01150-134
			A/R PLATE NUT	MS21059L3
2	1		ASSY BULKHEAD #3	21A01000-265
	1		BULKHEAD	21A01158-184
	1		ANGLE – NOSE BOX ATTACH	21A01326-006
	1		ANGLE – NOSE BOX ATTACH	21A01326-005
3	1		ASSY BULKHEAD #4	21A01000-261
	1		BULKHEAD – MAIN	21A01158-174
	1		SUPPORT – BULKHEAD LOWER	21A01158-175
	1		CLAMP, PUMP OUT TUBE	3A01158-003
4	1		ASSY BULKHEAD #5	21A01000-253
	1		BULKHEAD - MAIN	21A01158-178
	1		ANGLE – SIDE L.	21A01326-007
	1		ANGLE – SIDE R.	21A01326-008
	1		PANEL – SPR. BAR	21A01163-066
	1		SUPPORT – BULKHEAD LOWER	21A01158-177
	1		CLAMP, PUMP OUT TUBE	3A01158-003
5	1		ASSY BULKHEAD #6	21A01000-252
	1		BULKHEAD – MAIN	21A01158-189
	1		SUPPORT – BULKHEAD LOWER	21A01158-177
	1		GROMMET	MS35489-19
6	1		ASSY BULKHEAD #7	21S01000-308
	1		BULKHEAD - MAIN	21A01158-189
	1		SUPPORT – BULKHEAD LOWER	21A01158-177
	1		CLAMP, PUMP OUT TUBE	3A01158-003
7	1		ASSY BULKHEAD #8	21S01000-309
	1		BULKHEAD – MAIN	21A01158-189



WIPLINE MODEL 2100 FLOAT PARTS MANUAL

HULL ASSEMBLY - SEAPLANE, FIGURE 2

<u>REF NO.</u>	<u>NO.</u>	<u>REQ.</u>	<u>PART DESCRIPTION</u>	<u>PART NO.</u>
	1		SUPPORT – BULKHEAD LOWER	21A01158-177
	2		ANGLE – A.B. SKIN ATTACH	21A01158-203
	1		CLAMP, PUMP OUT TUBE	3A01158-003
8	1		ASSY. – BULKHEAD #10	21S01000-322
	1		BULKHEAD - MAIN	21A01158-169
	1		ANGLE SIDE L.	21A01326-011
	1		ANGLE SIDE R.	21A01326-012
	1		PANEL – SPR. BAR	21A01163-066
	2		ANGLE – VERTICAL	21S01340-129
	1		CLAMP, PUMP OUT TUBE	3A01158-003
9	1		BULKHEAD #11	21A01000-395
10	1		BULKHEAD #12	21A01000-396
11	1		BULKHEAD #13	21A01000-397
12	1		ASSY. BULKHEAD #14	21A01000-250
	1		BULKHEAD - MAIN	21A01158-164
	1		CHANNEL – REIN.	21A01158-165
	1		PLATE – WATER RUDDER STOP	21A08156-130
13	1		ASSY. SPR. BAR PANEL FWD	21A01000-260
	1		PANEL – SPR. BAR	21A01163-065
	1		ANGLE – SIDE L.	21A01326-013
	1		ANGLE – SIDE R.	21A01326-014
	1		BOLT	AN4-5A
	1		WASHER	NAS1149F0463P
	1		NUT	MS21044N4
14	1		ASSY. SPR. BAR PANEL AFT	21A01000-259
	1		PANEL – SPR. BAR	21A01163-065
	1		ANGLE – SIDE L.	21A01326-009
	1		ANGLE – SIDE R.	21A01326-010

WIPLINE MODEL 2100 FLOAT PARTS MANUAL

HULL ASSEMBLY - SEAPLANE, FIGURE 2

<u>REF NO.</u>	<u>NO. REQ.</u>	<u>PART DESCRIPTION</u>	<u>PART NO.</u>
	1	BOLT	AN4-5A
	1	WASHER	NAS1149F0463P
	1	NUT	MS21044N4
15	1	NOSE BUMPER	21S01738-001
16	1	SIDE SKIN – STEP TO BOW L. OUTBR'D	21S01004-123
	1	SIDE SKIN – STEP TO BOW R. OUTBR'D	21S01004-122
	1	SIDE SKIN – STEP TO BOW L. INBR'D	21S01004-125
	1	SIDE SKIN – STEP TO BOW R. INBR'D	21S01004-124
	1	BRACKET (PADDLE)	1002114
	1	STOP (LEFT)	3A01156-057
	1	STOP (RIGHT)	1002113
	1	CLIP	3A01503-001
	1	PADDLE	0238-0035
17	1	SIDE SKIN – STEP TO STERN L. OUTBR'D	21A01004-097
	1	SIDE SKIN – STEP TO STERN R. OUTBR'D	21A01004-098
	1	SIDE SKIN – STEP TO STERN L. INBR'D	21A01004-099
	1	SIDE SKIN – STEP TO STERN R. INBR'D	21A01004-100
		<u>NOTE:</u> DIFFERENCE BETWEEN R. AND L. IS FINISH	
18	2	STIFFENER – SIDE SKIN	21A01340-105
19	2	STIFFENER – SIDE SKIN	21A01340-104
20	1	ASSY. BOTTOM SKIN FWD L.	21A01000-307
	1	SKIN ONLY	21A01005-265
	1	ASSY. BOTTOM SKIN FWD R.	21A01000-306
	1	SKIN ONLY	21A01005-265
		(ASSY. INCLUDES BONDED STIFFENERS)	
	2	STIFFENER	21A01322-001
	2	STIFFENER	21A01322-002
	2	STIFFENER	21A01322-003
	2	STIFFENER	21A01322-004

WIPLINE MODEL 2100 FLOAT PARTS MANUAL

HULL ASSEMBLY - SEAPLANE, FIGURE 2

<u>REF NO.</u>	<u>NO.</u>	<u>REQ.</u>	<u>PART DESCRIPTION</u>	<u>PART NO.</u>
	2		STIFFENER	21A01322-005
	6		STIFFENER	21A01322-006
21	1		BOTTOM SKIN AFTERBODY L.	21S01004-131
	1		BOTTOM SKIN AFTERBODY R.	21S01004-130
22	1		ASSY. SPRAY RAIL L.	21A01000-275
	1		ASSY. SPRAY RAIL R.	21A01000-274
23	1		BOOSTER – SISTER KEEL L.	21A01000-429
	1		BOOSTER – SISTER KEEL R.	21A01000-428
24	1		DOUBLER – GUNWALL AFT L.	21A01162-033
	1		DOUBLER – GUNWALL AFT R.	21A01162-034
25	1		DOUBLER – GUNWALL FWD L.	21A01162-031
	1		DOUBLER – GUNWALL FWD R.	21A01162-032
26	2		TUBE – SPR. BAR MOUNTING	21A03115-001
	6		BOLT	AN4-22A
	12		WASHER	NAS1149D0416J
	12		WASHER	NAS1149D0463J
	6		NUT	MS21044N4

THIS PAGE INTENTIONALLY LEFT BLANK

WIPLINE MODEL 2100 FLOAT PARTS MANUAL

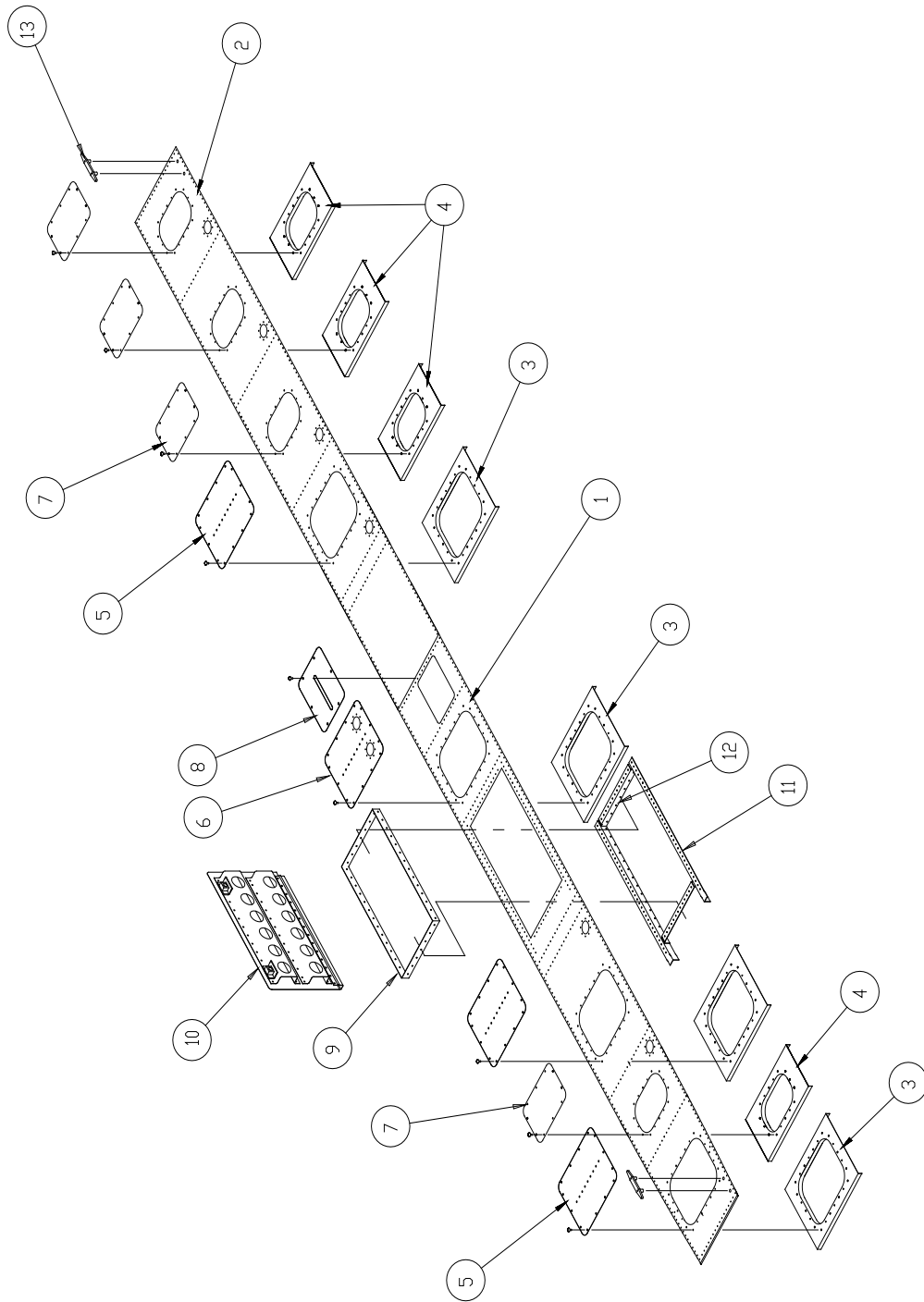

TOP SKIN – HULL – AMPHIBIAN  
FIGURE 3

WIPLINE MODEL 2100 FLOAT PARTS MANUAL

TOP SKIN - HULL – AMPHIBIAN, FIGURE 3

<u>REF NO.</u>	<u>NO.</u>	<u>REQ.</u>	<u>PART DESCRIPTION</u>	<u>PART NO.</u>
1	1		SKIN – FWD SECTION L.	21A01004-089
	1		SKIN – FWD SECTION R.	21A01004-090
2	1		SKIN – AFT SECTION L.	21A01004-091
	1		SKIN – AFT SECTION R.	21A01004-092
3	4		SUPPORT – INSP. COVER - LARGE A/R TINNERMAN WITH TAPE	21A01002-130 1002481
4	4		SUPPORT – INSP. COVER – SMALL A/R TINNERMAN WITH TAPE	21A01002-131 1002481
5	3		INSP. COVER ASSY– LARGE – W/ ANGLE & GASKET A/R SCREW – ATTACH	21A01000-258 SS TATP 8 X 5/8
	3		SEAL – GASKET ONLY (FORMED COVER)	1001437
	3		SEAL – GASKET ONLY (FLAT COVER)	21A01567-001
6	1		INSP. COVER – LARGE – W/ ANGLE (2 CUPS) & GASKET A/R SCREW – ATTACH	21A01000-273 SS TATP 8 X 5/8
	3		SEAL – GASKET ONLY (FORMED COVER)	1001437
	3		SEAL – GASKET ONLY (FLAT COVER)	21A01567-001
7	4		INSP. COVER ASSY - SMALL A/R SCREW – ATTACH	21A01000-284 SS TATP 8 X 5/8
	3		SEAL – GASKET ONLY (FORMED COVER)	1001437
	3		SEAL – GASKET ONLY (FLAT COVER)	21A01567-002
8	1		COVER – GEAR INDICATOR L.	21A01002-137
	1		COVER – GEAR INDICATOR R.	21A01002-138
	1		PLACARD – DOWN - LAND	10A3-6338-1
	1		PLACARD – UP - WATER	10A3-6338-2
	4		SCREW – CAM - LOK	2600-3
	2		SCREW – CAM – LOK	1126000-5
	6		RECEPTACLE – CAM – LOK	212-12N

WIPLINE MODEL 2100 FLOAT PARTS MANUAL

TOP SKIN - HULL – AMPHIBIAN, FIGURE 3

<u>REF NO.</u>	<u>NO.</u>	<u>REQ.</u>	<u>PART DESCRIPTION</u>	<u>PART NO.</u>
9	1		JAMB – BAGGAGE DOOR	21A01150-131
	1		BAGGAGE JAMB, HINGE SIDE	1002067
10	1		ASSY – BAGGAGE DOOR	21A01000-268
	1		COVER - SKIN	21A01162-035
	1		HINGE	21A01740-008
	1		HINGE	21A01741-004
	2		STIFFENER - DOOR	21A01010-012
	2		STIFFENER ENDS	21A01004-106
	2		RETAINER - LOCK	3A01206-001
	2		LOCK PIN	3A01273-004
	2		CATCH – LATCH	3A01702-001
	2		LOCK SPRING	3A01525-003
	2		RING – OPENING	1002663
	1		SEAL – GASKET (NOT SHOWN)	1001438
	1		HINGE PIN	1002186
	12		RIVET POP	01692-0410
2		BOLT	10/32 X ½ SS	
11	1		TOP RAIL – BAGGAGE OPENING L.	21A01326-003
	1		TOP RAIL – BAGGAGE OPENING R.	21A01326-002
12	2		JAMB – BAGGAGE DOOR	21A01326-004
13	2		CLEAT – TIE DOWN	21A01203-001
	4		BUSHING	21A01280-004
	4		SCREW – ATTACH	AN525-10R24
	4		NUT	MS21044N3
	4		WASHER	NAS1149D0363J

THIS PAGE INTENTIONALLY LEFT BLANK



WIPLINE MODEL 2100 FLOAT PARTS MANUAL

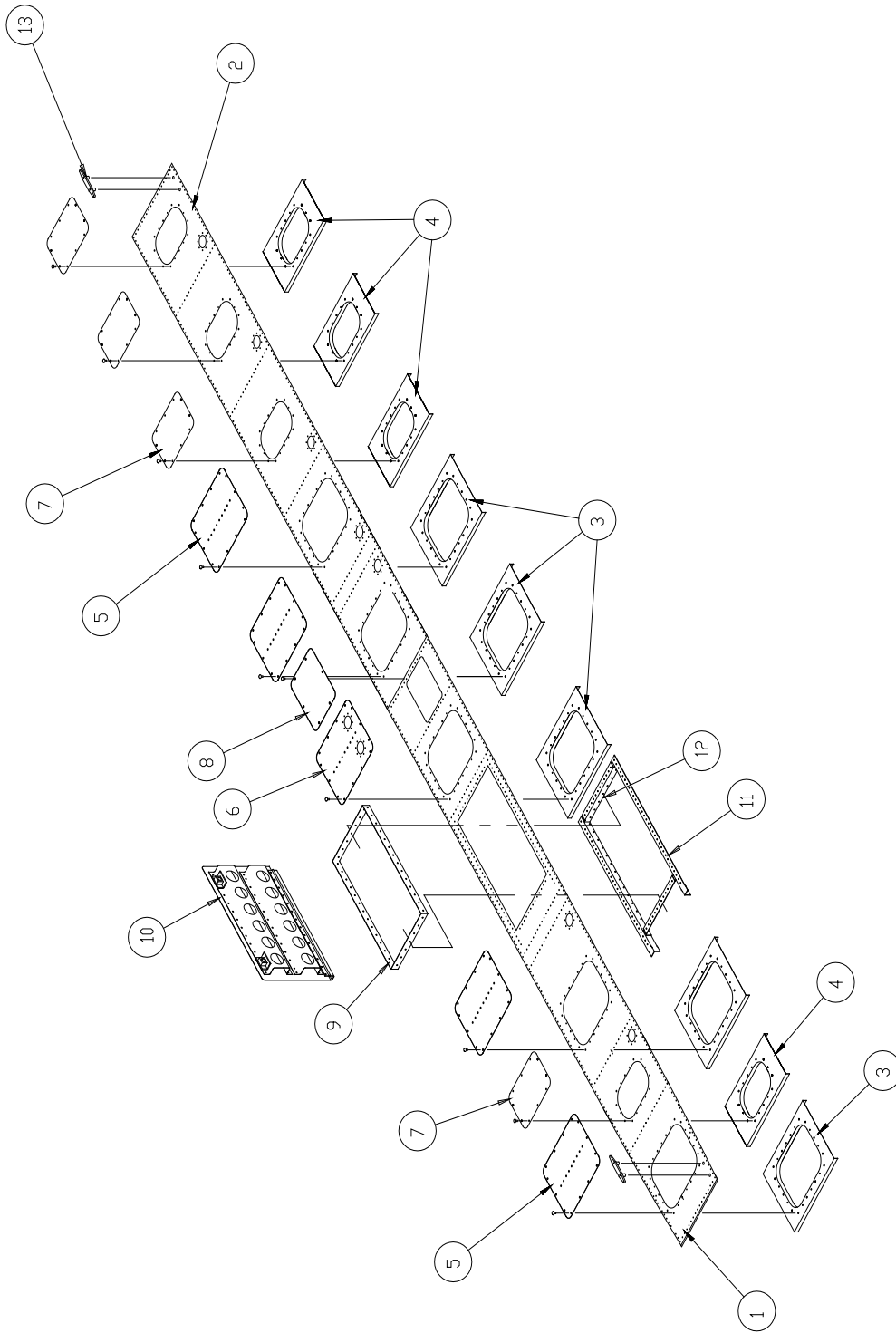

TOP SKIN – HULL – SEAPLANE  
FIGURE 4

WIPLINE MODEL 2100 FLOAT PARTS MANUAL

TOP SKIN - HULL – SEAPLANE, FIGURE 4

<u>REF NO.</u>	<u>NO.</u>	<u>REQ.</u>	<u>PART DESCRIPTION</u>	<u>PART NO</u>
1	1		SKIN – FWD SECTION L.	21S01004-135
	1		SKIN – FWD SECTION R.	21S01004-134
2	1		SKIN – AFT SECTION L.	21S01004-137
	1		SKIN – AFT SECTION R.	21S01004-136
3	4		SUPPORT – INSP. COVER - LARGE A/R TINNERMAN WITH TAPE	21A01002-130 1002481
4	5		SUPPORT – INSP. COVER – SMALL A/R TINNERMAN WITH TAPE	21A01002-131 1002481
5	4		INSP. COVER ASSY – LARGE – W/ ANGLE & GASKET A/R SCREW – ATTACH	21A01000-258 SS TATP 8 X 5/8
	3		SEAL – GASKET ONLY (FORMED COVER)	1001437
	3		SEAL – GASKET ONLY (FLAT COVER)	21A01567-001
6	1		INSP. COVER – LARGE – ANGLE (2 CUPS) & GASKET A/R SCREW – ATTACH	2A01000-273 SS TATP 8 X 5/8
	3		SEAL – GASKET ONLY (FORMED COVER)	1001437
	3		SEAL – GASKET ONLY (FLAT COVER)	21A01567-001
7	4		INSP. COVER ASSY- SMALL & GASKET A/R SCREW – ATTACH	21A01000-284 SS TATP 8 X 5/8
	4		SEAL – GASKET ONLY (FORMED COVER)	1001728
	3		SEAL – GASKET ONLY (FLAT COVER)	21A01567-002
8	1		COVER ASSY & GASKET	21S01000-399
	1		SEAL – GASKET ONLY	1002110
			A/R SCREW – ATTACH	SS TATP 8 X 5/8
			A/R NUT – TINNERMAN	9A3-671
	2		STIFFENER – ANGLE	30S01326-035
9	1		JAMB – BAGGAGE DOOR	21A01150-131
	1		SEAL – GASKET (NOT SHOWN)	101438

WIPLINE MODEL 2100 FLOAT PARTS MANUAL

TOP SKIN - HULL – SEAPLANE, FIGURE 4

<u>REF NO.</u>	<u>NO.</u>	<u>REQ.</u>	<u>PART DESCRIPTION</u>	<u>PART NO.</u>
	1		JAMB – HINGE SIDE	1002067
10	1		ASSY – BAGGAGE DOOR	21A01000-268
	1		COVER - SKIN	21A01162-035
	1		HINGE	21A01741-004
	2		STIFFENER - DOOR	21A01010-012
	2		STIFFENER ENDS	21A01004-106
	2		RETAINER - LOCK	3A01206-001
	2		LOCK PIN	3A01273-004
	2		CATCH – LATCH	3A01702-001
	2		LOCK SPRING	3A01525-003
	2		RING – OPENING	9-0177A221
	1		SEAL – GASKET (NOT SHOWN)	101438
11	1		TOP RAIL – BAGGAGE OPENING L.	21A01326-003
	1		TOP RAIL – BAGGAGE OPENING R.	21A01326-002
12	2		JAMB – BAGGAGE DOOR	21A01326-004
13	2		CLEAT – TIE DOWN	21A01203-001
	4		BUSHING	21A01280-004
	4		SCREW – ATTACH	AN525-10R24
	4		NUT	MS21044N3
	4		WASHER	NAS1149D0363J
1	1		SKIN – FWD SECTION L.	21S01004-135
	1		SKIN – FWD SECTION R.	21S01004-134

THIS PAGE INTENTIONALLY LEFT BLANK

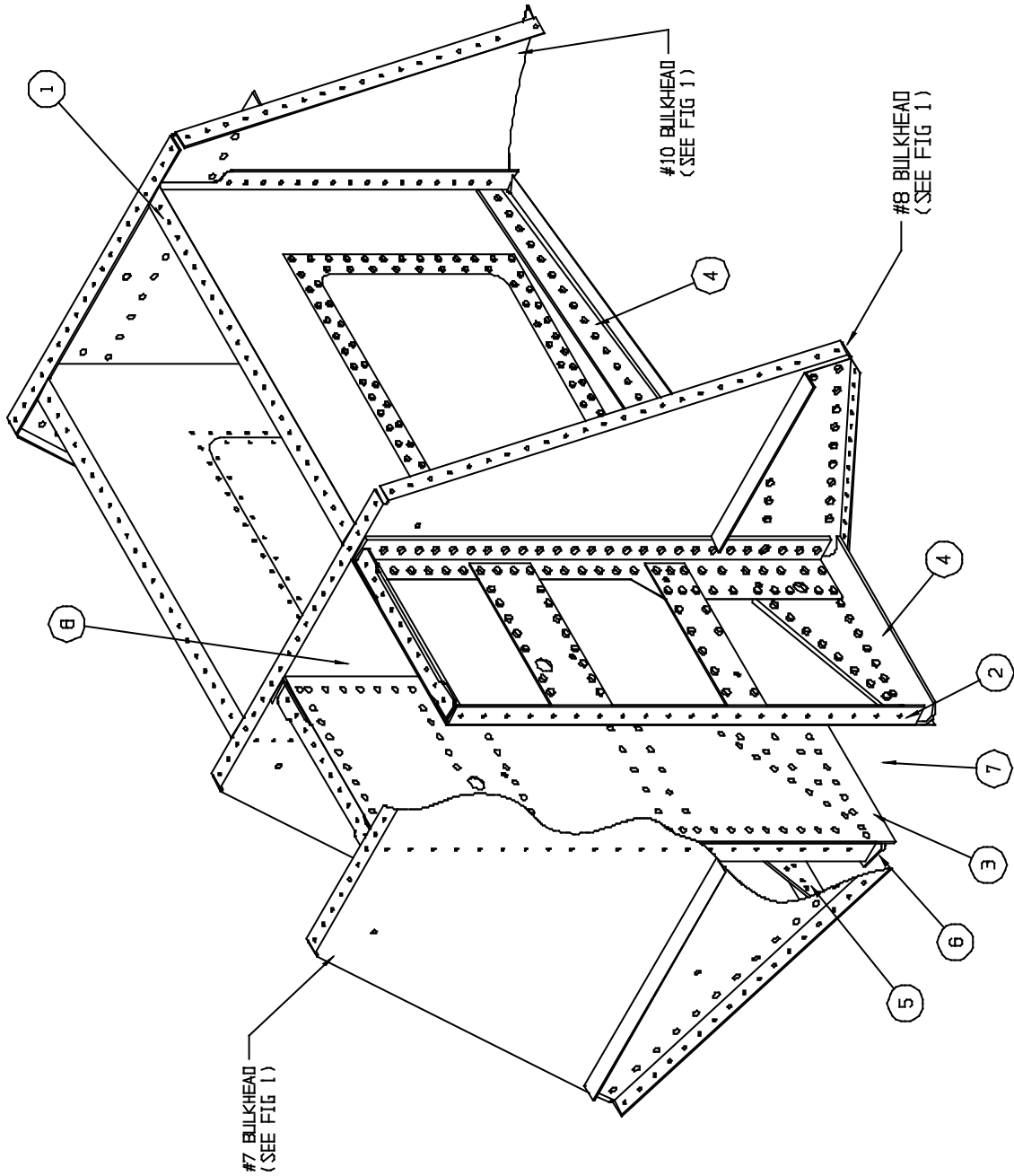

WHEELWELL ASSEMBLY – AMPHIBIAN  
FIGURE 5

1	1	ASSY. – WHEELWELL HALF L.	21A01000-289
	1	PANEL – FORMED L.	21A01158-185
	1	RING – COVER REINFORCEMENT	13A01156-124
	1	COVER	21A01158-163
	28	SCREW	AN526-632R6
	1	ASSY. – WHEELWELL HALF R.	21A01000-290
	1	PANEL – FORMED R.	21A01158-186
	1	RING – COVER REINFORCEMENT	13A01156-124
	1	COVER	21A01158-163
	28	SCREW	AN526-632R6
2	1	ASSY. – WHEELWELL PANEL – OUTBR'D L.	21A01000-257
	1	ASSY. - WHEELWELL PANEL – OUTBR'D R.	21A01000-256
3	1	ASSY. – WHEELWELL PANEL – INBR'D L.	21A01000-255
	1	ASSY. - WHEELWELL PANEL – INBR'D R.	21A01000-254
4	1	CARRY-THRU STRAP OUTBR'D L.	21A01017-005
	1	CARRY-THRU STRAP OUTBR'D R.	21A01017-004
5	1	CARRY-THRU STRAP INBR'D L.	21A01017-003
	1	CARRY-THRU STRAP INBR'D R.	21A01017-002
6	1	CARRY-THRU STRAP INBR'D L.	21A01017-007
	1	CARRY-THRU STRAP INBR'D R.	21A01017-006
	1	ANGLE – ATTACH AFT L.	21A01156-131
	1	ANGLE – ATTACH AFT R.	21A01156-132
	1	SHIM	21A01156-125
	2	ANGLE – ATTACH FWD	21A01326-015
7	1	SAND GUARD ASSY. (NOT SHOWN)	21A01000-398
	1	SAND GUARD (NOT SHOWN)	21A01150-136
	4	SCREW	AN526-1032R8
	4	NUT PLATE	MS21078-3
8	1	MUD FLAP (NOT SHOWN)	21A01569-001
	1	REINFORCEMENT	21A01150-135

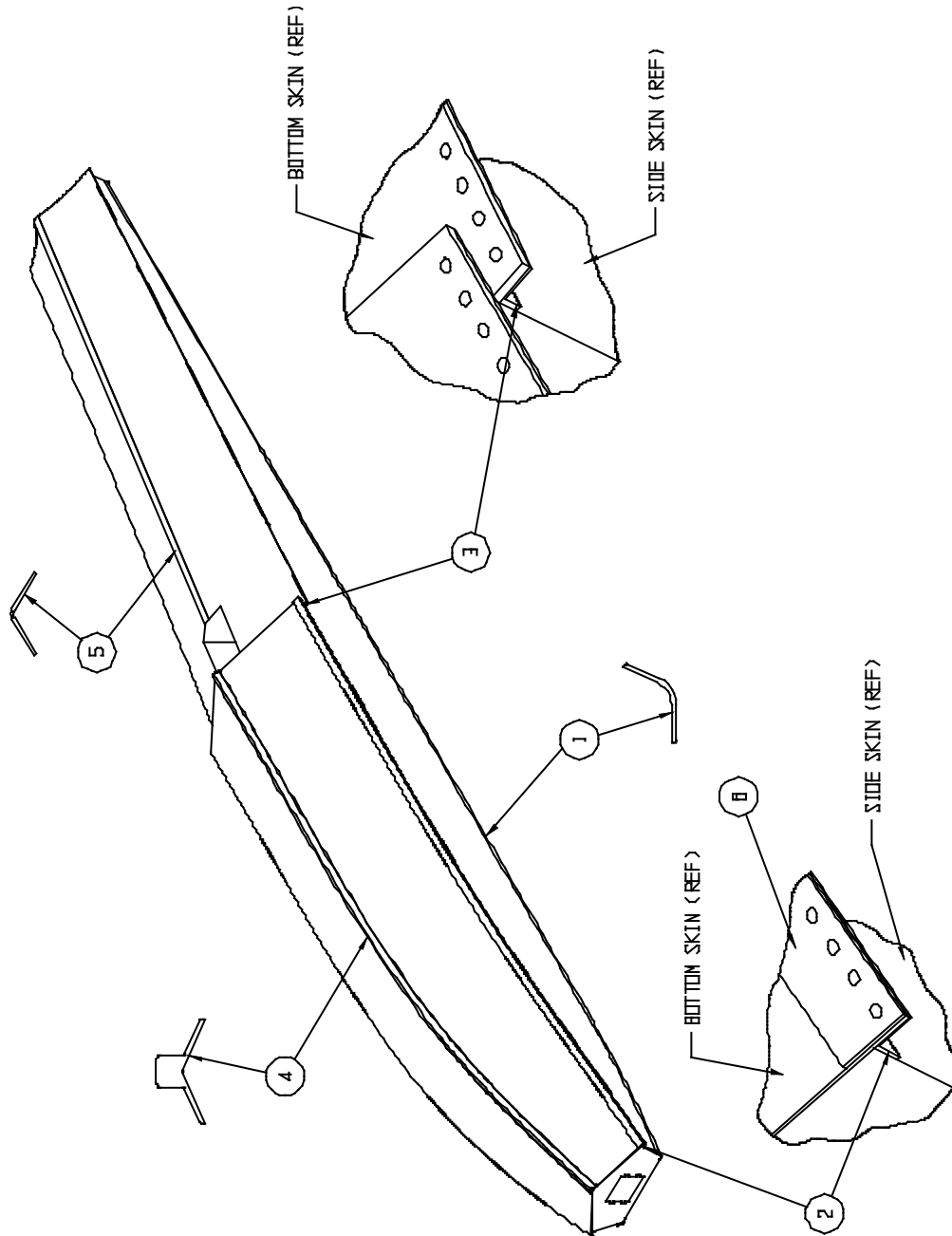

EXTRUSIONS – HULL – ASSEMBLY  
FIGURE 6

WIPLINE MODEL 2100 FLOAT PARTS MANUAL

EXTRUSIONS – HULL – ASSEMBLY, FIGURE 6

<u>REF NO.</u>	<u>NO.</u>	<u>REQ.</u>	<u>PART DESCRIPTION</u>	<u>PART NO.</u>
1	1		GUNWALL – L.	21A01324-001
	1		GUNWALL – R.	21A01324-002
2	1		CHINE - FWD L.	21A01340-109
	1		CHINE – FWD R.	21A01340-108
3	1		CHINE – AFTERBODY L.	21A01340-107
	1		CHINE – AFTERBODY R.	21A01340-106
4	1		KEEL - MAIN	21A01321-001
5	1		KEEL - AFTERBODY	21A01008-142



WIPLINE MODEL 2100 FLOAT PARTS MANUAL

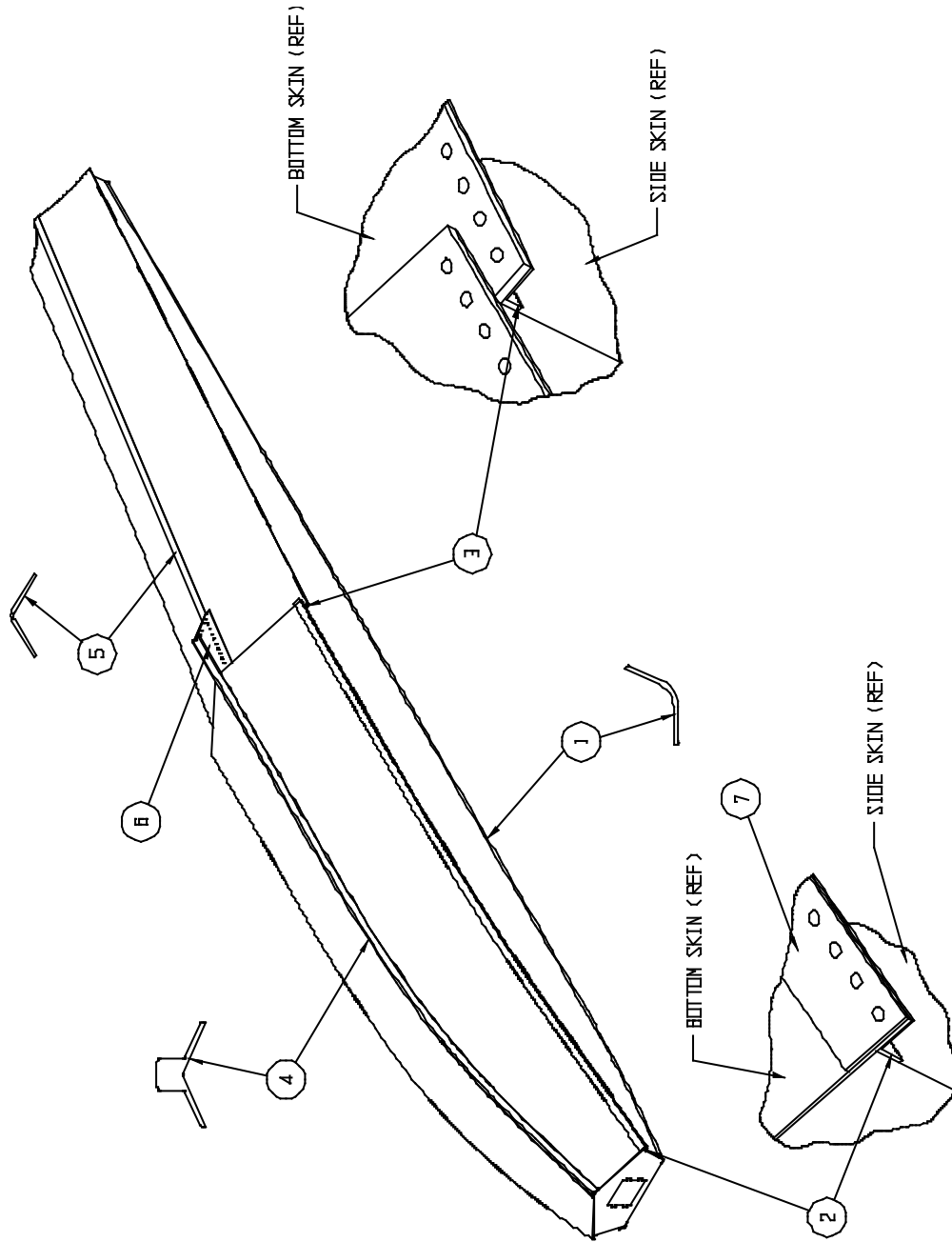

EXTRUSIONS – HULL – SEAPLANE  
FIGURE 7

WIPLINE MODEL 2100 FLOAT PARTS MANUAL

EXTRUSIONS – HULL – SEAPLANE, FIGURE 7

<u>REF NO.</u>	<u>NO.</u>	<u>REQ.</u>	<u>PART DESCRIPTION</u>	<u>PART NO.</u>
1	1		GUNWALL – L.	21A01324-001
	1		GUNWALL – R.	21A01324-002
2	1		CHINE - FWD L.	21A01340-109
	1		CHINE – FWD R.	21A01340-108
3	1		CHINE – AFTERBODY L.	21A01340-107
	1		CHINE – AFTERBODY R.	21A01340-106
4	1		KEEL - MAIN	21S01321-004
5	1		KEEL - AFTERBODY	21S01008-172
6	1		AFTERBODY GUSSET ASSY.	21S01000-400
	1		ANGLE SUPPORT – AFTERBODY L.	21S01163-037
	1		ANGLE SUPPORT – AFTERBODY R.	21S01163-038

WIPLINE MODEL 2100 FLOAT PARTS MANUAL

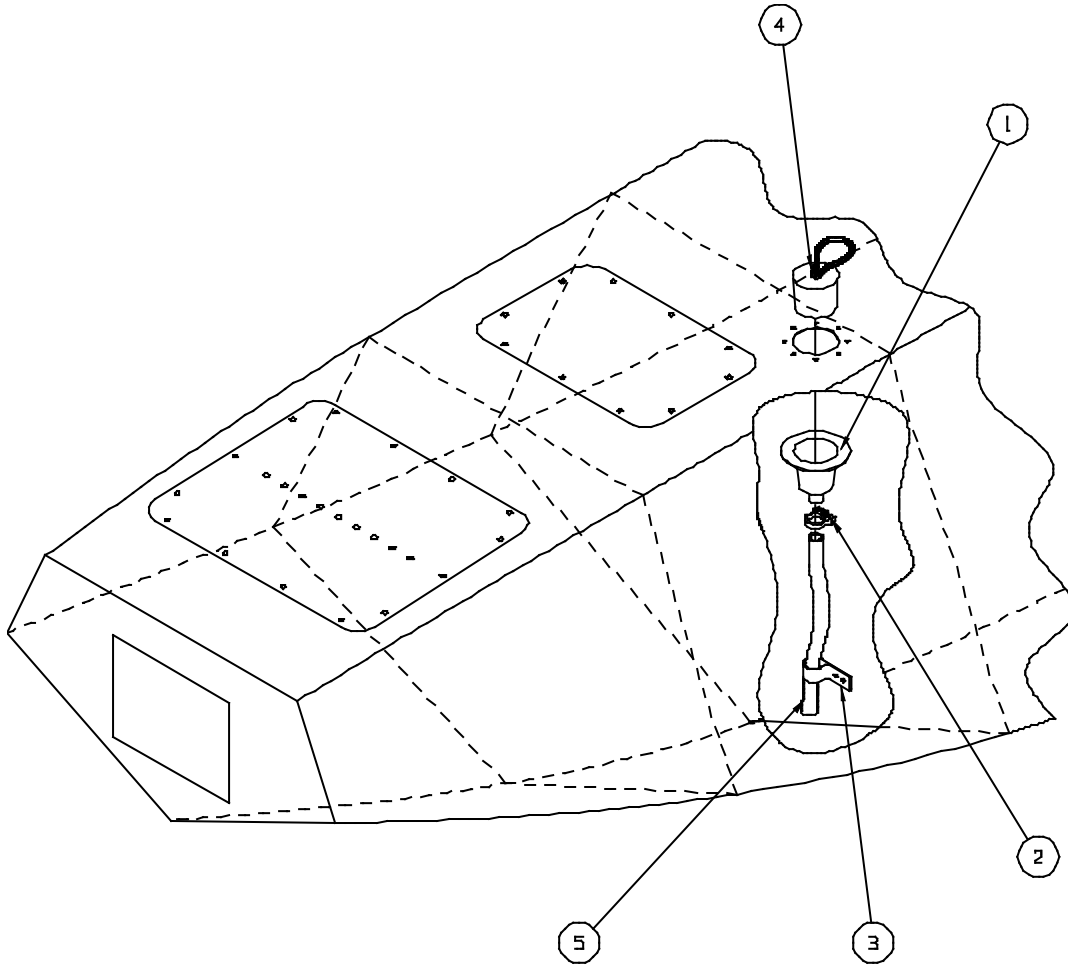

PUMPER TUBE INSTALLATION  
FIGURE 8

WIPLINE MODEL 2100 FLOAT PARTS MANUAL

PUMPER TUBE INSTALLATION, FIGURE 8

<u>REF NO.</u>	<u>NO.</u>	<u>REQ.</u>	<u>PART DESCRIPTION</u>	<u>PART NO.</u>
1	1		CUP – PUMPOUT ALUM. A/R RIVETS	4A01749-001 MS20470AD4-4
2	1		CLAMP – UPPER END	57134
3	1		CLAMP – LOWER END	3A01158-003
4	1		STOPPER – PUMPER TUBE	2111
5	1		PUMPOUT TUBE 10.5 IN.	21A01618-062
	1		PUMPOUT TUBE 12.5 IN.	21A01648-061
	1		PUMPOUT TUBE 15.0 IN.	21A01648-060
	1		PUMPOUT TUBE 17.5 IN.	21A01618-059
	1		PUMPOUT TUBE 23.0 IN.	21A01648-058
	1		PUMPOUT TUBE 21.5 IN.	21A01648-056
	1		PUMPOUT TUBE 18.5 IN.	21A01648-055

WIPLINE MODEL 2100 FLOAT PARTS MANUAL

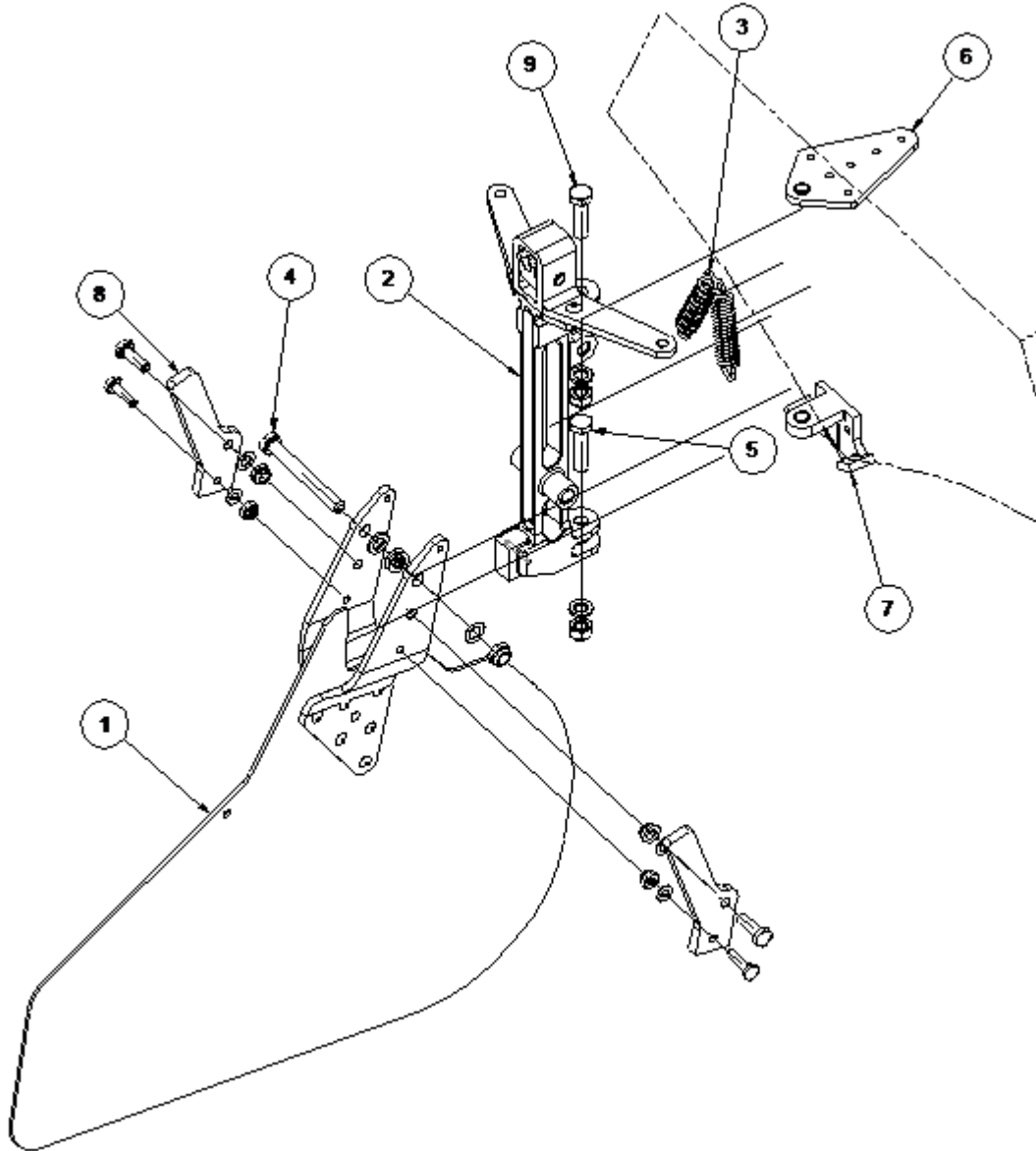

INSTALLATION WATER RUDDER  
FIGURE 9

WIPLINE MODEL 2100 FLOAT PARTS MANUAL

INSTALLATION WATER RUDDER, FIGURE 9

<u>REF NO.</u>	<u>NO. REQ.</u>	<u>PART DESCRIPTION</u>	<u>PART NO.</u>
1	1	ASSY. - BLADE	21A08000-123
	1	BLADE	1002649
	1	ARM L.	21A08019-001
	1	ARM R.	21A08019-002
2	1	WATER RUDDER POST WITH BELLCRANK ASSEMBLY	1003858
	1	WATER RUDDER POST ASSEMBLY	1003854
	1	BELLCRANK, WATER RUDDER POST ASSEMBLY	1003853
	1	BUMBER, DOWN STOP	21A08648-002
	1	ROLL PIN	1001457
	1	GUIDE, RETRACT	21A8602-009
	1	PIN ATTACH	5/16 x 1 ½ inches
3	2	SPRING	21A08525-006
4	1	BOLT - ATTACH	AN5-25A
	3	WASHER	NAS1149D0516J
	1	WASHER	NAS 1149D0563J
	1	NUT	MS21083N5
5	1	BOLT, ATTACH	AN5-11A
	A/R	WASHER	NAS1149D0563J
	1	NUT	MS21044N5
6	1	ASSEMBLY – TOP BEARING	21A01000-299
	1	PLATE	21A01019-003
	1	BEARING	21A01705-003
7	1	ASSEMBLY – LOWER BEARING	21A08000-157
	1	BRACKET	21A08318-002
	1	BEARING	05DU06
8	2	STOP	21A08154-009
	2	BOLT – ATTACH LOWER	AN4-6A
	2	WASHER	NAS1149D0416J

WIPLINE MODEL 2100 FLOAT PARTS MANUAL

INSTALLATION WATER RUDDER, FIGURE 9

<u>REF NO.</u>	<u>NO. REQ.</u>	<u>PART DESCRIPTION</u>	<u>PART NO.</u>
	2	NUT	MS21083N4
	2	BOLT – ATTACH LOWER	AN3-6A
	2	WASHER	NAS1149D0316J
	2	NUT	MS21044N3
9	1	BOLT, ATTACH	AN5-12A
		A/R WASHER	NAS1149D0563J
	1	NUT	MS21044N5

THIS PAGE INTENTIONALLY LEFT BLANK



WIPLINE MODEL 2100 FLOAT PARTS MANUAL

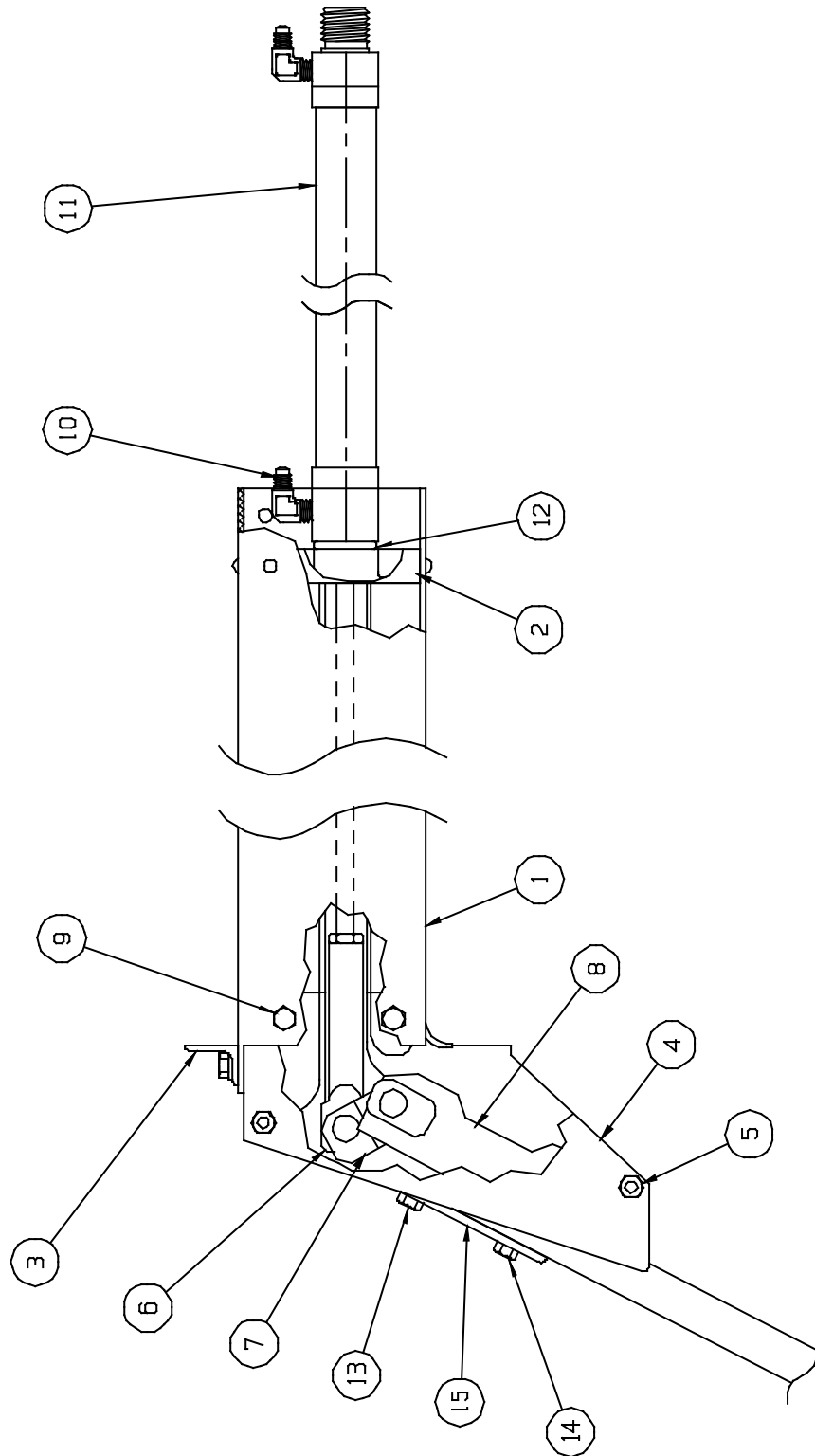

ASSEMBLY – NOSE GEAR RETRACTION  
FIGURE 10

WIPLINE MODEL 2100 FLOAT PARTS MANUAL

ASSEMBLY – NOSE GEAR RETRACTION, FIGURE 10

<u>REF NO.</u>	<u>NO. REQ.</u>	<u>PART DESCRIPTION</u>	<u>PART NO.</u>
1	1	ASSY. – NOSE BOX	21A07000-015
	1	NOSE – BOX	21A07323-001
	1	COVER – ACCESS	8A01008-080
	1	GASKET	30A07567-011
	4	SCREW	AN526-1032R4
2	1	END – CAP - AFT	21A07237-002
3	1	ANGLE	21A07359-194
	2	BOLT	AN4-6A
	2	WASHER	NAS1149D0463J
	2	WASHER	NAS1149D0416J
	2	NUT	MS21044N4
4	1	TRACK – NOSE END L.	21A07349-003
	1	TRACK – NOSE END R.	21A07349-004
5	2	BOLT	AN4-53A
	4	WASHER	NAS1149D0416J
	2	NUT	NAS5679-A4W
6	1	ROD END - RAM	21A07094-002
	1	NUT - JAMB	AN316-5R
7	1	LINK – DOWN LOCK	21A07032-005
	1	AXLE – SHAFT	21A07509-007
	2	ROLLER	3A07530-001
	2	SNAP RING	5100-46-H
8	1	TROLLEY – SPRING ATTACH	21A07187-009
	2	AXLES - SHAFT	34A07509-008
	4	BLOCK - SLIDE	3A07604-001
9	4	BOLT	AN4-5A
	4	WASHER	NAS1149D0463J

WIPLINE MODEL 2100 FLOAT PARTS MANUAL

ASSEMBLY – NOSE GEAR RETRACTION, FIGURE 10

<u>REF NO.</u>	<u>NO.</u>	<u>REQ.</u>	<u>PART DESCRIPTION</u>	<u>PART NO.</u>
	8		WASHER	NAS1149D0416J
	4		NUT	NAS5679-A4W
10	1		ELBOW	MS20822-4D
11	1		HYDRAULIC CYLINDER	1002571
12	A/R		WASHER	NAS1149D1416J
13	2		BOLT	AN5-20A
			A/R WASHER	NAS1149F0563P
	2		NUT	MS21044N5
14	2		BOLT	AN5-21A
			A/R WASHER	NAS1149F0563P
	2		NUT	MS21044N5
15	1		PLATE – BEARING UPPER	21A06166-001
	2		CLIP-MAGNETIC INDICATOR (NOT SHOWN)	21A09005-262
	2		PROXIMITY SWITCH (NOT SHOWN)	5801
	4		SCREW (NOT SHOWN)	MS35206-215

THIS PAGE INTENTIONALLY LEFT BLANK

WIPLINE MODEL 2100 FLOAT PARTS MANUAL

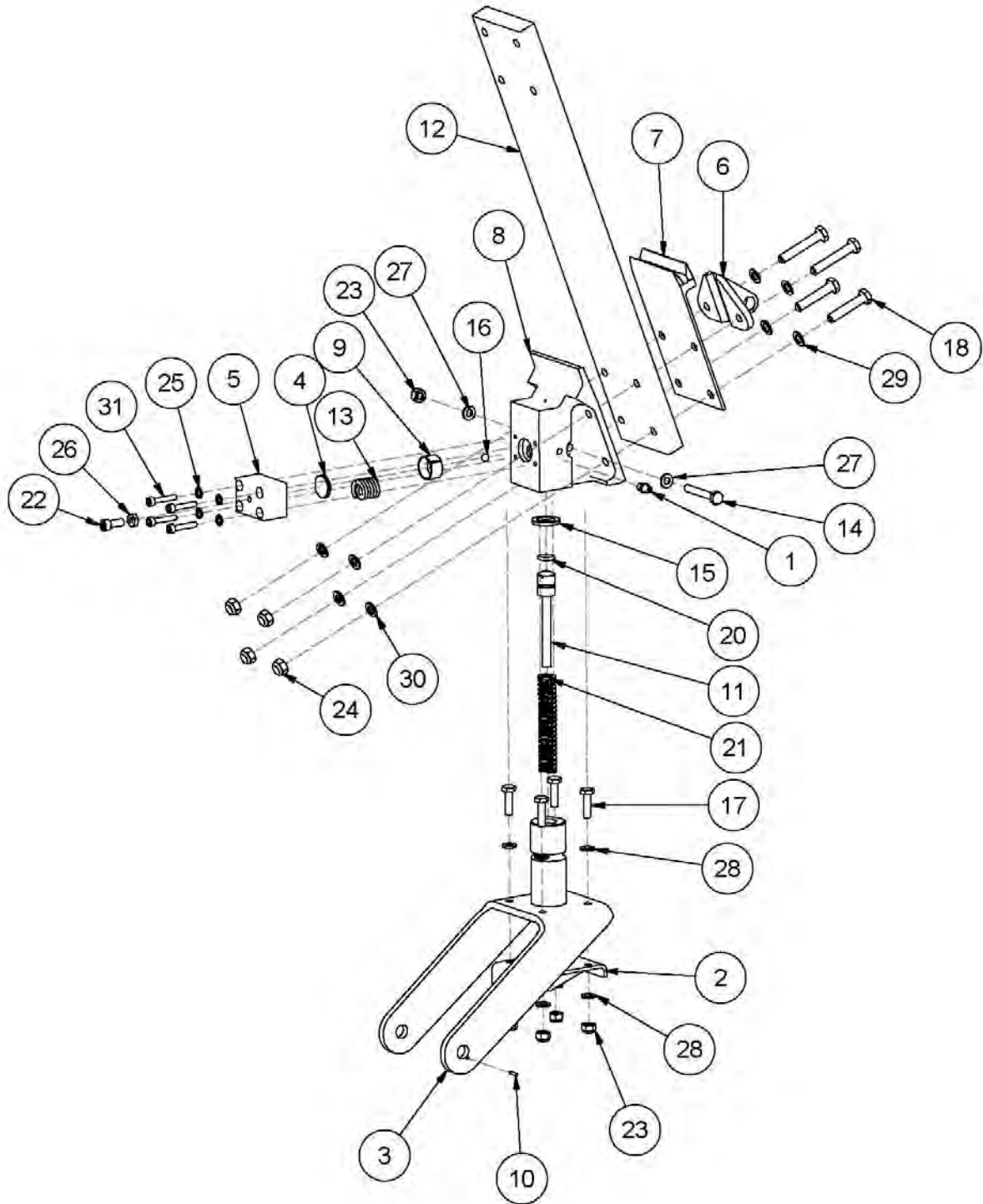

ASSEMBLY – NOSE GEAR – LOWER  
FIGURE 11

WIPLINE MODEL 2100 FLOAT PARTS MANUAL

ASSEMBLY – NOSE GEAR – LOWER, FIGURE 11

<u>REF NO.</u>	<u>NO. REQ.</u>	<u>PART DESCRIPTION</u>	<u>PART NO.</u>
1	1	COMMON GREASEZERK	1095K41
2	1	WELDMENT, PIVOT SHAFT, FORK, NOSE GEAR	21A06000-020
3	1	FORK, NOSE GEAR (2100)	21A06020-001
4	1	PRESSURE PLATE	21A06160-053
5	1	BLOCK - SPRING	21A06194-005
6	1	TOW HOOK NOSE GEAR	21A06213-006
7	1	BEARING PLATE, LOWER, NOSE GEAR	21A06237-001
8	1	BLOCK - PIVOT, NOSE GEAR	21A06318-005
9	1	FRICTION CUP	21A06475-006
10	1	PIN, ANTIROTATION	21A06476-003
11	1	PLUNGER- NOSE WHEEL, 21,23,3,34	21A06605-002
12	1	SPRING NOSE GEAR	21A06653-001
13	1	PRESSURE SPRING	21A06705-005
14	1	BOLT - MODIFIED, PIVOT BLOCK	30A06702-016
15	1	THRUST WASHER	3A06602-001
16	1	1/4" CHROME BALL BEARING	9528K15
17	4	BOLT	AN4-7A
18	2	BOLT	AN5-14A
19	2	BOLT	AN5-16A
20	1	O-RING	AN6227-9
21	1	SPRING	M62-350
22	1	SOCKET HEAD CAP SCREW	MS16997-60
23	5	NUT	MS21044N4
24	4	NUT	MS21044N5
25	4	STAR WASHER	MS35333-39
26	1	NUT	MS35649-2252
27	2	WASHER	NAS1149D0463J
28	8	WASHER	NAS1149F0463P
29	4	WASHER	NAS1149F0532P
30	4	WASHER	NAS1149F0563P
31	4	SOCKET HEAD CAP SCREW	NAS1352-316P

WIPLINE MODEL 2100 FLOAT PARTS MANUAL

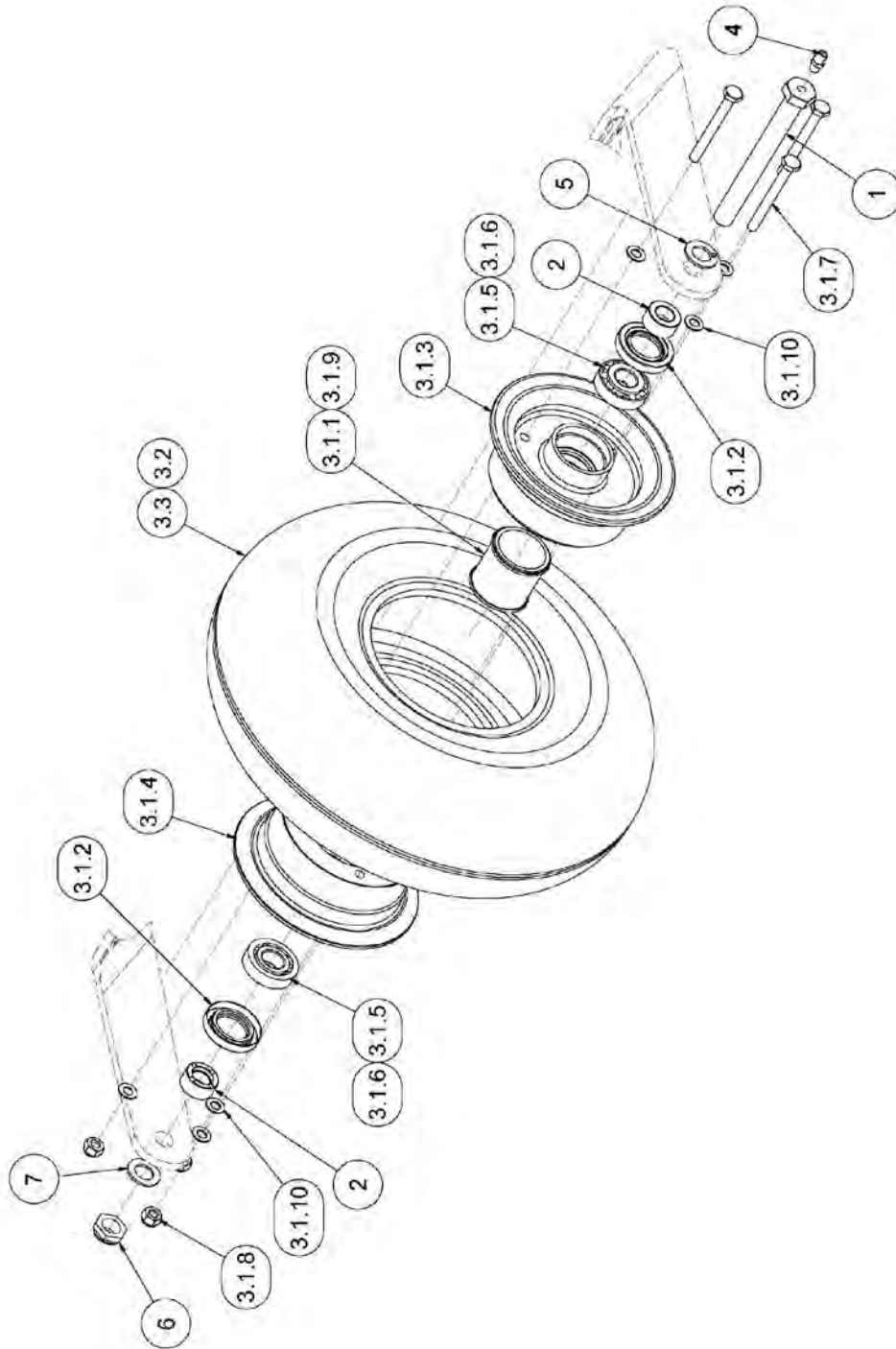

ASSEMBLY – NOSE WHEEL (GROVE)  
FIGURE 12A

WIPLINE MODEL 2100 FLOAT PARTS MANUAL  
ASSEMBLY – NOSE WHEEL (GROVE), FIGURE 12A

<u>REF NO.</u>	<u>NO.</u>	<u>REQ.</u>	<u>PART DESCRIPTION</u>	<u>PART NO.</u>
1	1		BOLT, AXLE, NOSE GEAR	1005927
2	2		SPACER	1005929
3	1		ASSEMBLY, NOSE WHEEL	1005931
3.1	1		ASSEMBLY, WHEEL, GROVE	49-12AF-001
3.1.1	1		GREASE RETAINER	010-019
3.1.2	2		SEAL	010-026
3.1.3	1		WHEEL HALF INNER	015-020A
3.1.4	1		WHEEL HALF OUTER	016-020AF
3.1.5	2		BEARING CORE	A4050
3.1.6	2		BEARING CONE	A4138
3.1.7	3		BOLT	AN4-23A
3.1.8	3		NUT	MS21044N-4
3.1.9	2		O-RING	MS28775-029
3.1.10	6		WASHER	NAS1149F0416
3.2	1		TIRE	XA1AA
3.3	1		TUBE	AD1A2
4	1		COMMON GREASEZERK	1095K41
5	1		MODIFIED WASHER	3A06702-003
6	1		NUT	MS21083N8
7	1		WASHER	NAS1149D0863J



WIPLINE MODEL 2100 FLOAT PARTS MANUAL

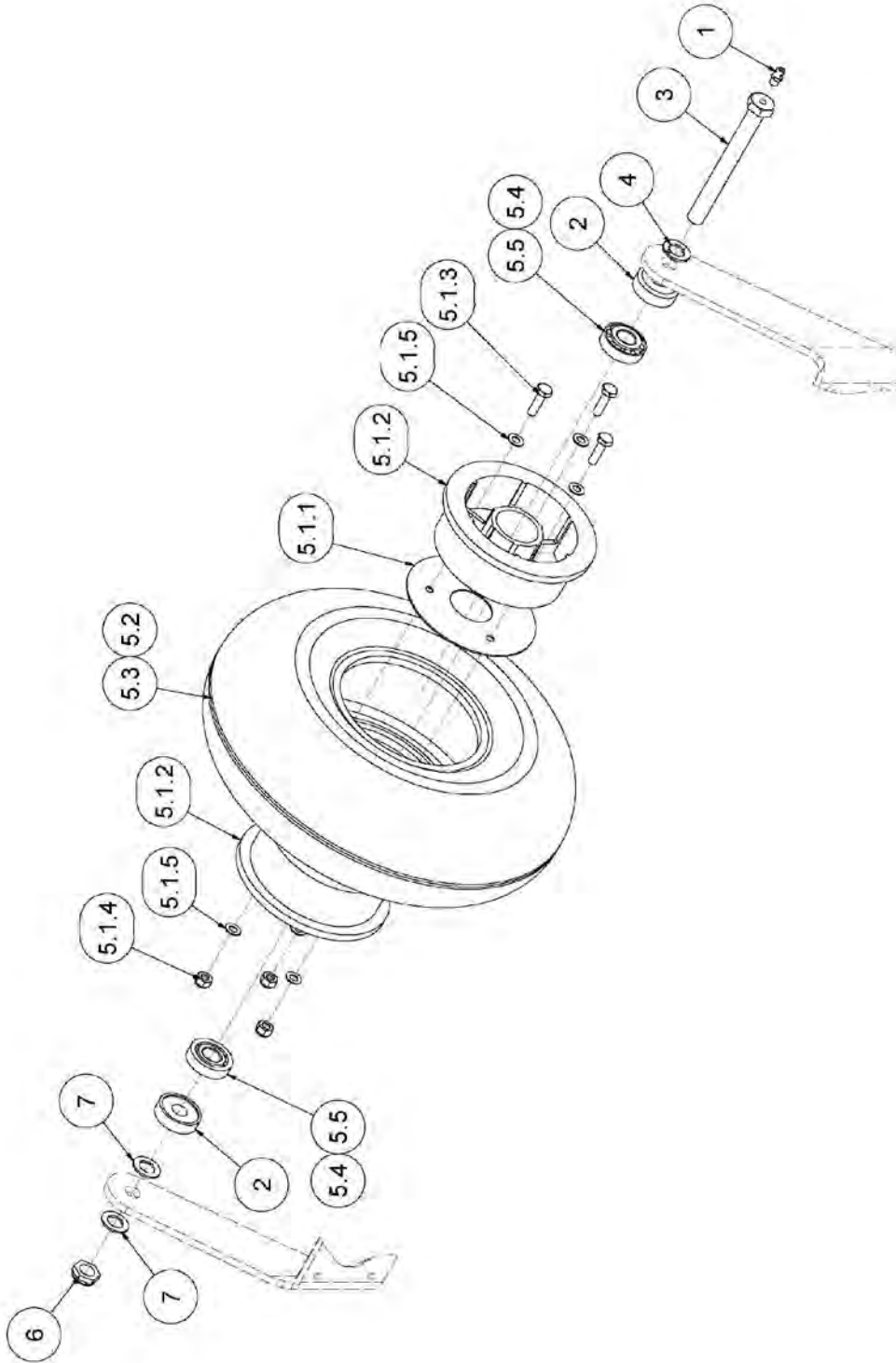

ASSEMBLY – NOSE WHEEL (PARKER)  
FIGURE 12A

WIPLINE MODEL 2100 FLOAT PARTS MANUAL

ASSEMBLY – NOSE WHEEL (PARKER), FIGURE 12B

<u>REF</u> <u>NO.</u>	<u>NO.</u> <u>REQ.</u>	<u>PART DESCRIPTION</u>	<u>PART NO.</u>
1	1	COMMON GREASEZERK	1095K41
2	2	SPACER	3A06259-001
3	1	MODIFIED BOLT	3A06702-002
4	1	MODIFIED WASHER	3A06702-003
5	1	NOSE WHEEL ASSEMBLY	21A06000-021
5.1	1	PARKER WHEEL ASSEMBLY	D-30380
5.1.1	1	GASKET	068-30373
5.1.2	2	WHEEL HALF	161-30382
5.1.3	3	BOLT	AN4-7A
5.1.4	3	NUT	MS21044N4
5.1.5	6	WASHER	NAS1149F0432P
5.2	1	TIRE	XA1AA
5.3	1	TUBE	AD1A2
5.4	2	BEARING CORE	A4050
5.5	2	BEARING CONE	A4138
6	1	NUT	MS21083N8
7	2	WASHER	NAS1149D0863J

WIPLINE MODEL 2100 FLOAT PARTS MANUAL

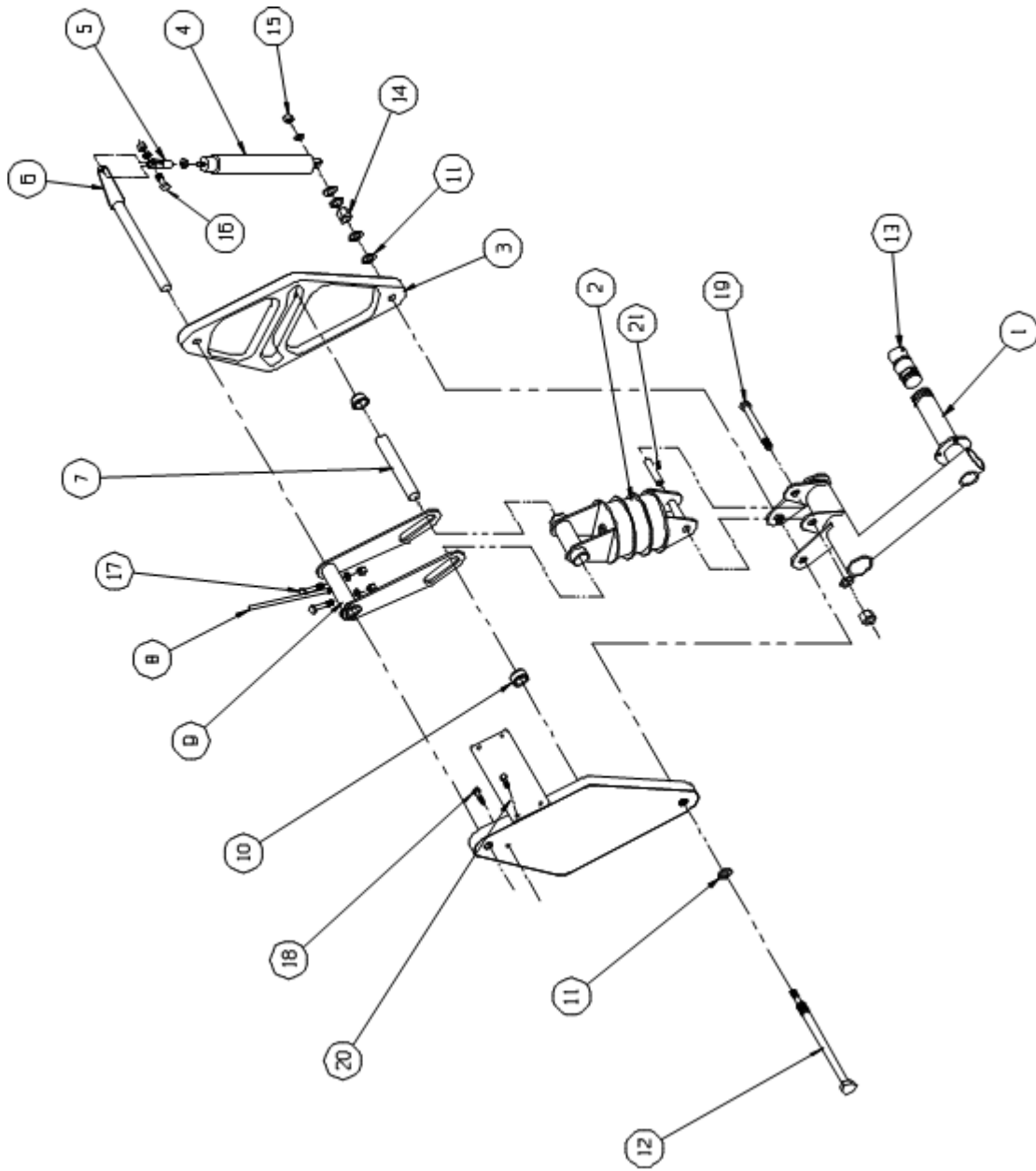

INSTALLATION – MAIN GEAR RETRACTION  
FIGURE 13

WIPLINE MODEL 2100 FLOAT PARTS MANUAL

INSTALLATION – MAIN GEAR RETRACTION, FIGURE 13

<u>REF NO.</u>	<u>NO.</u>	<u>REQ.</u>	<u>PART DESCRIPTION</u>	<u>PART NO.</u>
1	1		ASSY. – DRAG LINK L.	21A04000-077
	1		ASSY. – DRAG LINK R.	21A04000-076
	2		BEARING	08FDU12
2	1		ASSY. SHOCK STRUT	21A04000-073
	1		ASSY. - UPPER END	21A04000-074
	1		ASSY. – LOWER END	21A04000-075
	2		ZERK – GREASE	1095K41
	2		WASHER	NAS1149D0416J
	2		WASHER	NAS1149D0463J
	1		DUAL BUSHING ASSEMBLY	1002087
	1		BUSHING ASSEMBLY	1001101
	1		RETAINING PIN	21A04503-004
	1		COTTER PIN	MS24665-151
	1		SLEEVES	21A04585-002
3	1		TRACK – MAIN GEAR L.	21A05114-005
	1		TRACK – MAIN GEAR R.	21A05114-006
	1		BEARING - UPPER	10DU12
	1		BEARING – LOWER	08DU12
4	1		CYLINDER	1002574
	2		FITTING - ELBOW	MS20822-4D
5	1		ROD END	21A05705-002
	1		JAMB NUT	AN316-5
	1		SPACER	21A05260-005
	1		CHAMFERED WASHER (CHAMFERED EDGE GOES AGAINST CYLINGER)	MS20002C6
6	1		ARM – RETRACT L.	21A05000-017
	1		ARM – RETRACT R.	21A05000-016
7	1		AXLE – SHOCK STRUT	21A04454-006

WIPLINE MODEL 2100 FLOAT PARTS MANUAL

INSTALLATION – MAIN GEAR RETRACTION, FIGURE 13

<u>REF NO.</u>	<u>NO.</u>	<u>REQ.</u>	<u>PART DESCRIPTION</u>	<u>PART NO.</u>
8	1		INDICTATOR ASSY.	21A05000-022
9	1		GEAR ACTUATOR	21A05000-018
10	2		ROLLER – TRACK	21A05520-003
11	2		WASHER – SEALING	93783A033
12	1		BOLT – ASSEMBLY	21A05000-019
	1		BOLT	21A05735-001
	1		STUD	21A05476-002
13	1		RETAINER - GREASE	21A04263-007
	2		“O” RING	Ms28775-210
	1		ZERK – GREASE	1095K41
14	1		NUT	MS21044N8
	2		WASHER	NAS1149F0863P
15	1		NUT	MS21083N5
	A/R		WASHER	NAS1149F0563P
16	1		BOLT	AN5-11A
	2		WASHER	NAS1149F0563P
	1		NUT	MS21044N5
17	2		BOLT	AN4-13A
	4		WASHER	NAS1149D0416J
	2		NUT	MS21044N4
18	8		BOLT – TRACK ATTACH	AN3-6A
	8		WASHER	NAS1149D0316J
	8		WASHER	NAS1149D0363J
	8		NUT	MS21044N3

WIPLINE MODEL 2100 FLOAT PARTS MANUAL

INSTALLATION – MAIN GEAR RETRACTION, FIGURE 13

<u>REF NO.</u>	<u>NO. REQ.</u>	<u>PART DESCRIPTION</u>	<u>PART NO.</u>
19	1	BOLT	AN8-33A
	1	WASHER	NAS1149F0832P
	1	WASHER	NAS1149F0863P
	1	NUT	MS21044N8
20	1	PLATE - SEPARATING	21A05003-079
	4	BOLT	AN3-5A
	8	WASHER	NAS1149D0316J
	4	NUT	MS21044N3
21	1	BUSHING - LOWER SHOCK STRUT	21A04547-004
	2	CLIP, MAGNETIC INDICATOR (NOT SHOWN)	21A09005-262
	2	PROXIMITY SWITCH (NOT SHOWN)	5801
	4	SCREW (NOT SHOWN)	MS35206-215

WIPLINE MODEL 2100 FLOAT PARTS MANUAL

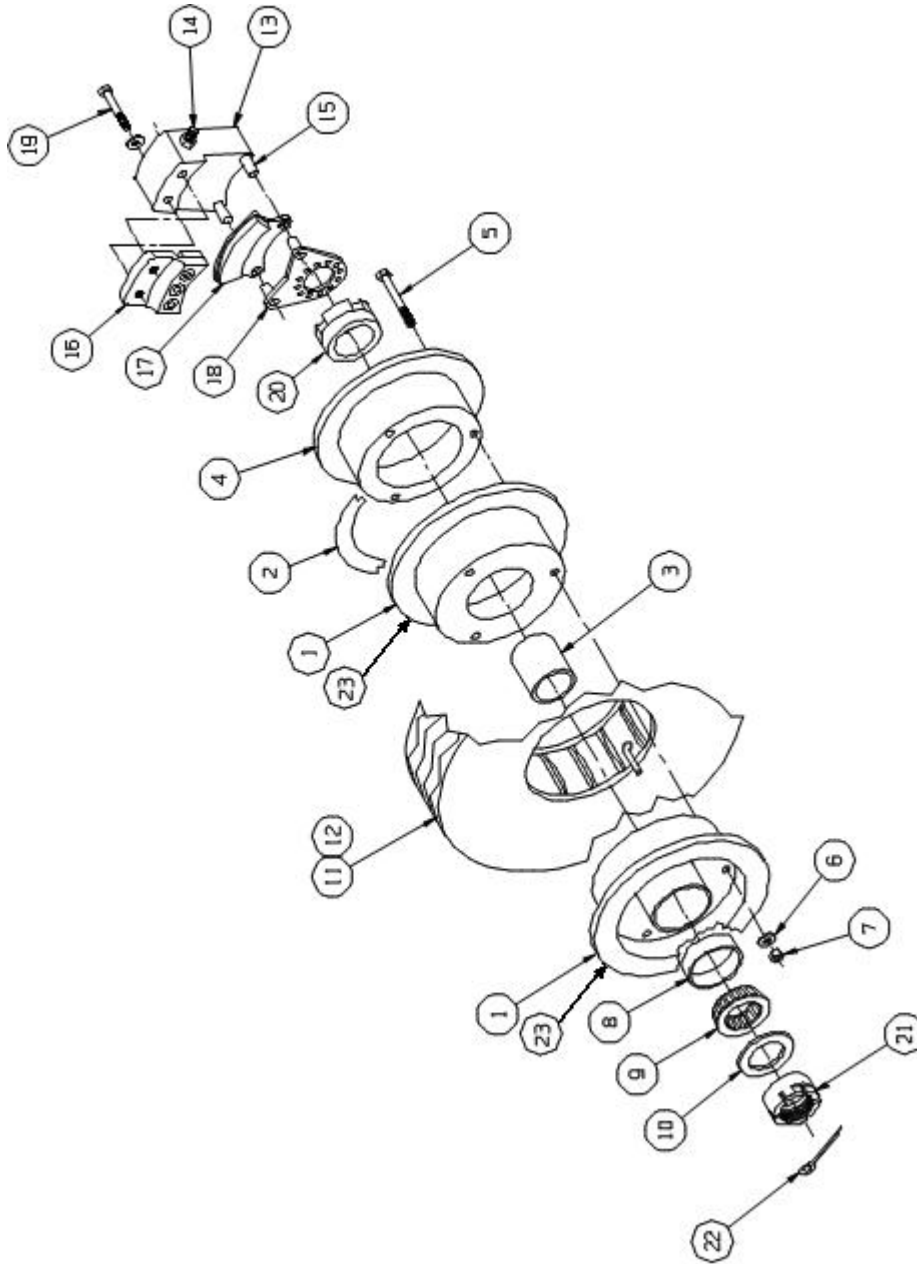

ASSEMBLY – MAIN GEAR WHEEL GROVE/WIPAIRE  
FIGURE 14A

WIPLINE MODEL 2100 FLOAT PARTS MANUAL

ASSEMBLY – MAIN GEAR WHEEL GROVE/WIPAIRE, FIGURE 14A

<u>REF NO.</u>	<u>NO.</u>	<u>PART DESCRIPTION</u>	<u>PART NO.</u>
1	1	ASS'Y – WHEEL AND BRAKE (COMPLETE) INCLUDES ALL ITEMS BELOW EXCEPT TIRE & TUBE	1002141
2	1	GASKET - TEFLON	3A04620-001
3	1	GREASE RETAINER	010-009
4	1	BRAKE DISC	018-001
5	3	BOLT	AN4-23A
6	3	WASHER	NAS1149F0432P
7	3	NUT	MS21044N4
8	2	BEARING RACE (CHROME)	08231-20027
9	2	BEARING CUP	08125-20027
10	2	SEAL - INSIDE/OUTSIDE	473237
11	1	TIRE –TYPE III 500 x 5, 6 PLY	AA1D4
12	1	TUBE 500 X 5	XA1AC
13	1	BRAKE ASSEMBLY	32-1
	2	PISTON	017-003
	2	O-RING	MS28775-217
14	1	BLEEDER ASSEMBLY	220-0063
	1	FITTING 45° BRAKE LINE	MS20823-3D
15	2	TORQUE PIN	013-001
	2	NUT	MS21044N4



WIPLINE MODEL 2100 FLOAT PARTS MANUAL

ASSEMBLY – MAIN GEAR WHEEL GROVE/WIPAIRE, FIGURE 14A

<u>REF NO.</u>	<u>NO. REQ.</u>	<u>PART DESCRIPTION</u>	<u>PART NO.</u>
16	1	ASS'Y – BACK PLATE	10-3
	1	PAD	66-111
	3	RIVET	105-2
17	1	ASS'Y – PRESSURE PLATE	11-2
	1	LINING	66-111
	3	RIVET	105-2
18	1	BRAKE TORQUE PLATE	020-001
19	3	BOLT	AN4H-15A
	3	WASHER	NAS1149F0432P
20	1	SPACER	3A04093-001
21	1	NUT – AXLE	3A04268-003
22	1	COTTER PIN	MS24665-351
23	1	WHEEL HALF-INNER	015-002
	1	WHEEL HALF-OUTER	016-002
		(HALVES NOT SOLD SEPERATELY)	

THIS PAGE INTENTIONALLY LEFT BLANK

WIPLINE MODEL 2100 FLOAT PARTS MANUAL

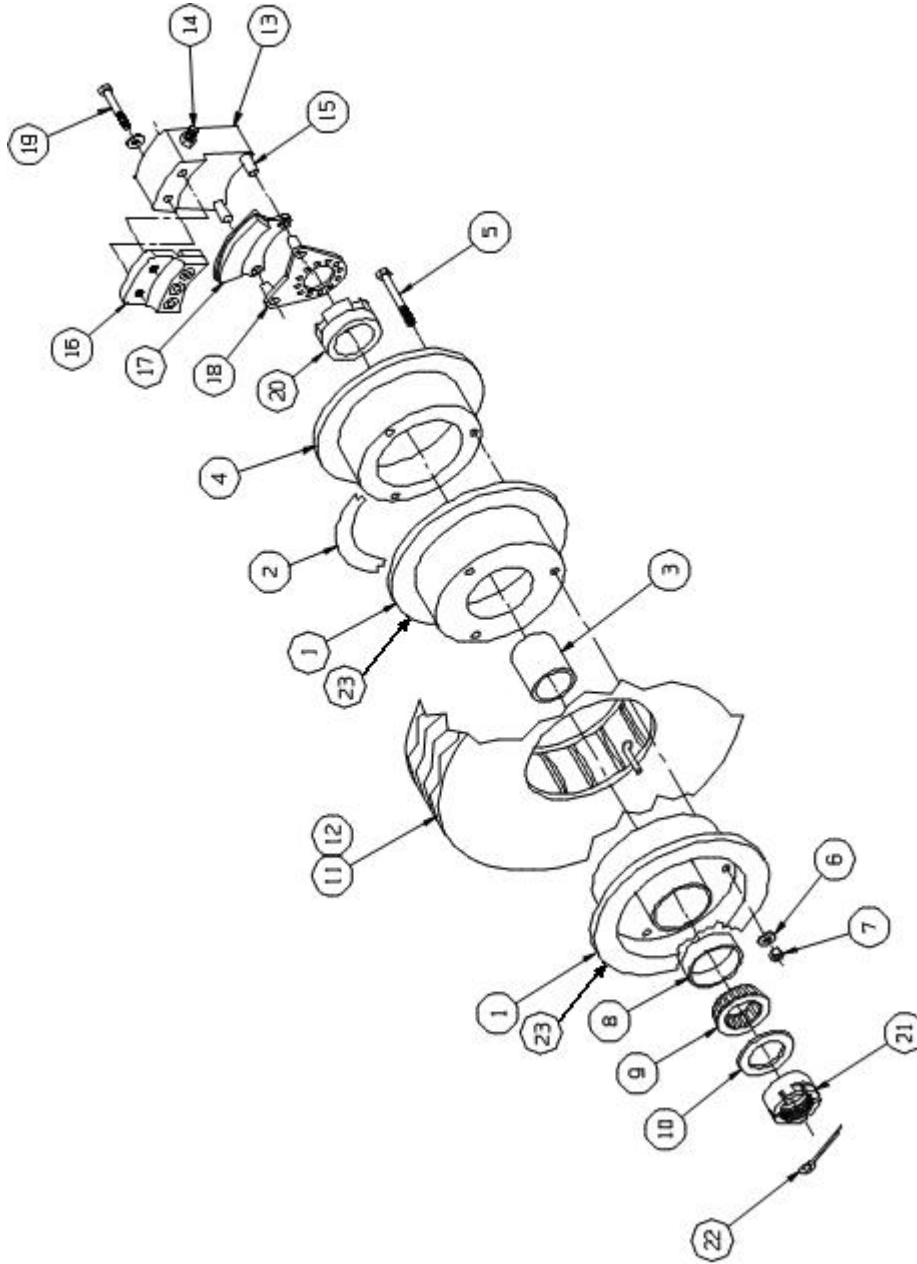

ASSEMBLY – MAIN GEAR WHEEL CLEVELAND/PARKER  
FIGURE 14B

WIPLINE MODEL 2100 FLOAT PARTS MANUAL

ASSEMBLY – MAIN GEAR WHEEL CLEVELAND/PARKER, FIGURE 14B

<u>REF NO.</u>	<u>NO. REQ.</u>	<u>PART DESCRIPTION</u>	<u>PART NO.</u>
1	1	ASSY. – WHEEL (W/ TUBE & TIRE)	3A04000-002
	1	ASSY. - WHEEL	3A04000-060
2	1	GASKET - TEFLON	3A04620-001
3	1	GREASE RETAINER	3A04616-001
4	1	BRAKE DISC	164-01700
5	3	BOLT	AN4-22A
6	3	WASHER	NAS1149F0432P
7	3	NUT	MS21044N4
8	2	BEARING CUP	8231
		BEARING CUP, CHROME (OPT.)	8231CP
9	2	BEARING CONE	8125
		BEARING CONE, CHROME (OPT.)	8125CP
10	2	SEAL - INSIDE/OUTSIDE	473237
11	1	TIRE –TYPE III	500 X 5, 6 PLY
12	1	TUBE	500 X 5
	1	ASSY. – BRAKE AND TORQUE PLATE	075-00800
13	1	ASSY. – CALIPER (RIGHT)	21A04000-096
	1	ASSY. – CALIPER (LEFT)	21A04000-097
	1	PISTON	062-00300
	1	“O” RING	AN6227-23
	1	FITTING - 45 DEGREES (BRAKE LINE)	MS20823-3D
14	1	SEAT – BLEEDER	081-30619

WIPLINE MODEL 2100 FLOAT PARTS MANUAL

ASSEMBLY – MAIN GEAR WHEEL, CLEVELAND/PARKER, FIGURE 14B

<u>REF NO.</u>	<u>NO.</u>	<u>REQ.</u>	<u>PART DESCRIPTION</u>	<u>PART NO.</u>
	1		SCREW – BLEEDER	79-3
	1		CAP – BLEEDER	183-1
15	2		ANCHOR BOLT	069-00400
	2		WASHER	NAS1149F0463P
	2		NUT	MS21044N4
16	1		ASSY. – BACK PLATE	074-02700
	1		PLATE – BACK	064-00500
	1		LINING	066-10600
	3		RIVET	105-2
17	1		ASSY. – PRESSURE PLATE	073-04800
	1		PLATE - PRESSURE	063-00500
	1		LINING	066-10600
	3		RIVET	105-2
18	1		BRAKE TORQUE PLATE - LEFT	3A04711-001
	1		BRAKE TORQUE PLATE – RIGHT	3A04711-002
19	1		BOLT	AN4H15A
	1		WASHER	NAS1149F0432P
20	1		SPACER	3A04093-001
21	1		NUT – AXLE	3A04268-003
22	1		COTTER PIN	MS24665-351
23	1		WHEEL HALF-INNER	015-002
	1		WHEEL HALF-OUTER	016-002
			(HALVES NOT SOLD SEPERATELY)	

THIS PAGE INTENTIONALLY LEFT BLANK

WIPLINE MODEL 2100 FLOAT PARTS MANUAL

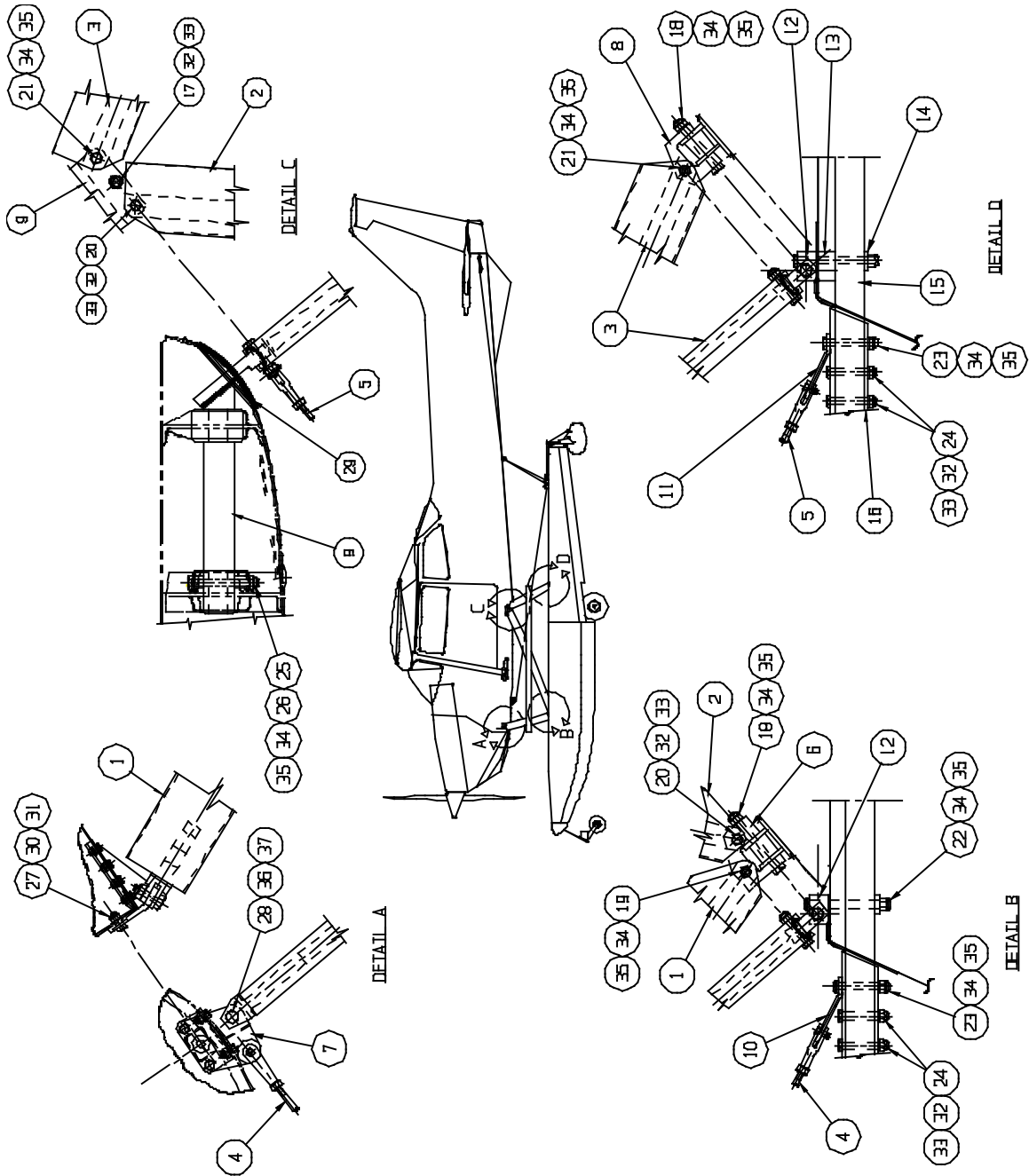

INSTALLATION – STRUTS, WIRES AND SPREADER BARS  
FIGURE 15

WIPLINE MODEL 2100 FLOAT PARTS MANUAL

INSTALLATION – STRUTS, WIRES, & SPREADER BARS, FIGURE 15

<u>REF NO.</u>	<u>NO.</u>	<u>REQ.</u>	<u>PART DESCRIPTION</u>	<u>PART NO.</u>
1	2		ASSY. – FRONT STRUT	21A02000-145
	1		STRUT	21A02334-020
	1		FITTING - UPPER	21A02053-008
	4		BOLT – FITTING ATTACH	AN5-14A
	8		WASHER	NAS1149D0363J
	4		NUT	MS21044N3
	2	2		ASSY. - STRUT – CENTER
3	2		ASSY. – STRUT – REAR	21A02000-161
4	2		ASSY. – DRAG WIRE – FWD	1002111
	1		WIRE	AN705AC-4900
	1		CLEVIS L.	AN665-61LS *
	1		CLEVIS R.	AN665-46RS *
	1		NUT CHECK L.	AN316C5L
	1		NUT CHECK R.	AN316C5R
	1		PIN – CLEVIS	MS20392-5C21
	1		PIN – CLEVIS	MS20392-4C17
	2		PIN – COTTER	MS24665-301
5	2		ASSY. – DRAG WIRE – AFT	21A02000-137
	1		WIRE	AN705AC-4525
	1		CLEVIS L.	AN665-46LS *
	1		CLEVIS R.	AN665-46RS *
	1		NUT CHECK L.	AN316-C5L
	1		NUT CHECK R.	AN316-C5R
	2		PIN – CLEVIS	MS20392-4C17
	2		PIN – COTTER	MS24665-152
	6	2		FITTING – LOWER FRONT STRUT
7	1		ASSY. - FITTING – UPPER FRONT STRUT L.	21A02000-141
	1		ASSY. – FITTING – UPPER FRONT STRUT R.	21A02000-142

\* \* “S” DENOTES STAINLESS STEEL



WIPLINE MODEL 2100 FLOAT PARTS MANUAL

INSTALLATION – STRUTS, WIRES, & SPREADER BARS, FIGURE 15

<u>REF NO.</u>	<u>NO. REQ.</u>	<u>PART DESCRIPTION</u>	<u>PART NO.</u>
8	2	FITTING – LOWER AFT STRUT	21A02062-010
9	1	ASSY. – MAIN FUSELAGE FITTING L.	21A02000-177
	1	BUSHING - INBOARD	21A02095-004
	1	BUSHING - OUTBOARD	21A02083-001
	1	ROLL PIN	MS16562-75
	1	ASSY. – MAIN FUSELAGE FITTING R.	21A02000-178
	1	BUSHING - INBOARD	21A02095-004
	1	BUSHING - OUTBOARD	21A02083-001
	1	ROLL PIN	MS16562-75
10	2	WIRE PULL LOWER FWD	21A02462-005
11	2	WIRE PULL LOWER AFT	21A02519-007
12	4	BLOCK – DECK FITTING	21A03032-006
13	4	SPACER	21A03214-003
14	4	CAP	21A03154-007
15	4	TUBE – SPREADER BAR MOUNT	21A03115-001
16	2	SPREADER BAR	21A03356-047
17	2	EYEBOLT	AN45-11A
18	4	BOLT	AN6-31A
19	2	BOLT	AN6-15A
20	2	BOLT	AN5-14A
21	4	BOLT	AN6-17A

WIPLINE MODEL 2100 FLOAT PARTS MANUAL

INSTALLATION – STRUTS, WIRES, & SPREADER BARS, FIGURE 15

<u>REF NO.</u>	<u>NO.</u>	<u>REQ.</u>	<u>PART DESCRIPTION</u>	<u>PART NO.</u>
22	4		BOLT	AN6-42A
23	4		BOLT	AN6-26A
24	8		BOLT	AN5-24A
25	2		BOLT	AN6-35A
26	4		BUSHING	21A02095-003
27	10		BOLT	AN4-6A
28	2		BOLT	AN7-13A
29	2		COVER – GEAR OPENING	21A02010-018
30	20		WASHER	NAS1149D0463J
31	10		NUT	MS21044N4
32	28		WASHER	NAS1149F0563P
33	14		NUT	MS21044N5
34	40		WASHER	NAS1149D0663J
35	20		NUT	MS21044N6
36	2		WASHER	NAS114D0763J
37	2		NUT	MS21044N7

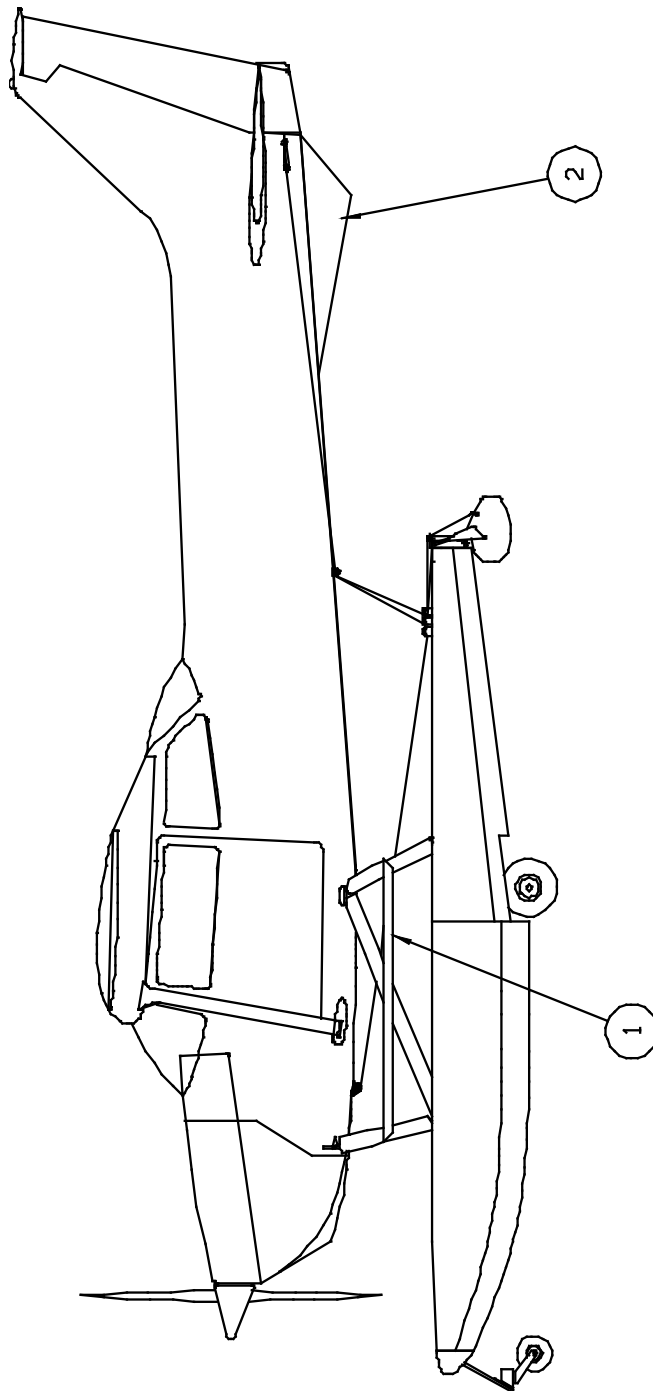

INSTALLATION – FUSELAGE STEPS  
FIGURE 16

WIPLINE MODEL 2100 FLOAT PARTS MANUAL

INSTALLATION – FUSELAGE STEPS, FIGURE 16

<u>REF NO.</u>	<u>NO.</u>	<u>REQ.</u>	<u>PART DESCRIPTION</u>	<u>PART NO.</u>
1	2		STEP – L. & R.	21A02369-035
	4		BOLT – ATTACH	AN3-20A
	2		BOLT – ATTACH	AN3-24A
	12		WASHER	NAS1149D0363J
	6		NUT	MS21044N3
	6		HOLE PLUG	BPF
	4		SPACER – FRONT STRUT	6A02273-006
	2	1		ASSY. – VENTRAL FIN
10			RIVNUTS	B8-75
14			PLATENUT	MS21078-08
24			SCREW – ATTACH	AN526-1032R8
24			WASHER	NAS1149D0363J
10			WASHER – LOCK	MS35333-39

WIPLINE MODEL 2100 FLOAT PARTS MANUAL

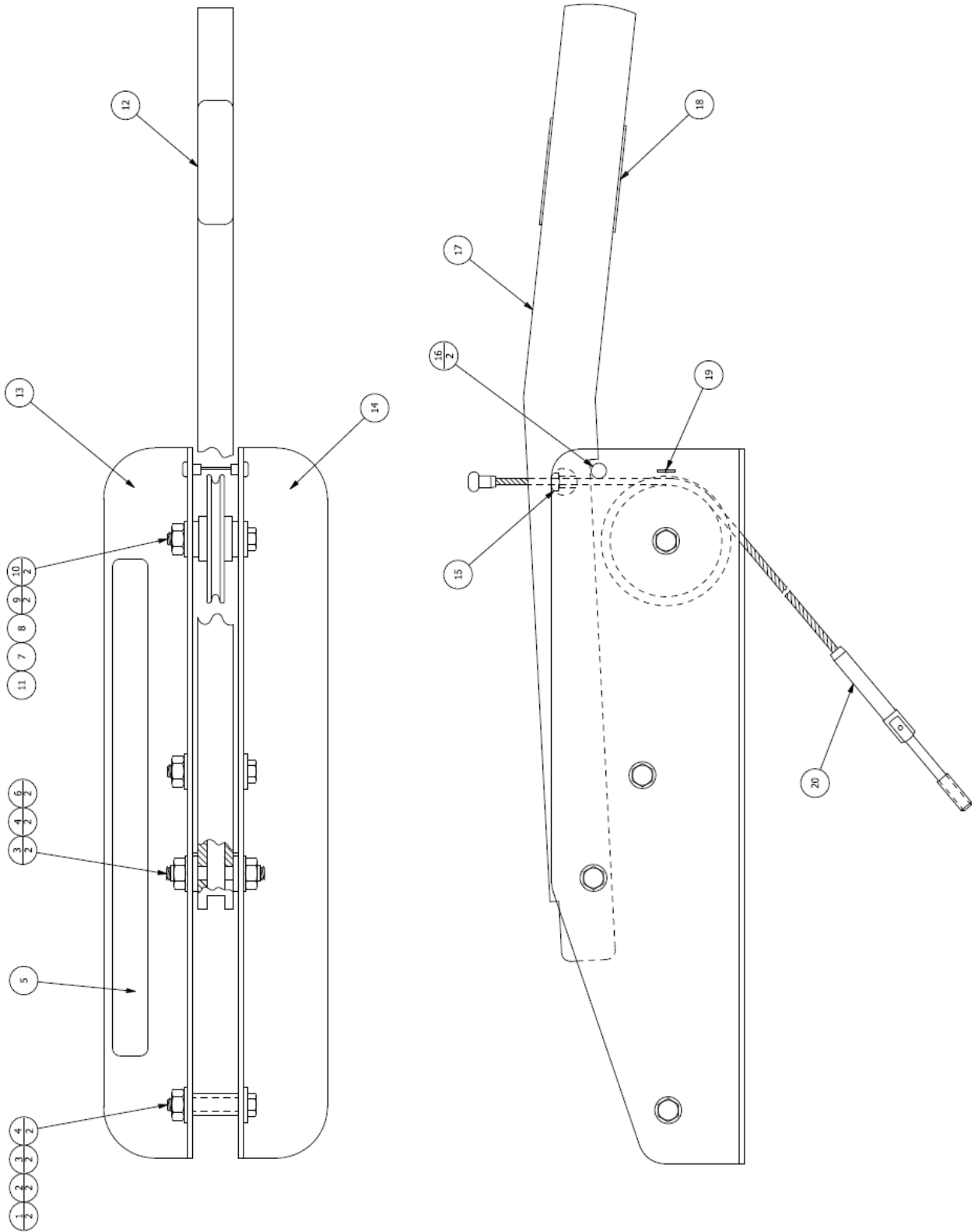

ASSEMBLY – RETRACT HANDLE  
FIGURE 17

WIPLINE MODEL 2100 FLOAT PARTS MANUAL  
 INSTALLATION – RETRACT HANDLE, FIGURE 17

<u>REF NO.</u>	<u>NO. REQ.</u>	<u>PART DESCRIPTION</u>	<u>PART NO.</u>
1	2	BOLT	AN3-10A
2	2	PLASTIC TUBE	3A08613-001
3	6	WASHER	NAS1149F0332P
4	4	NUT	NAS679A3W
5	1	PLACARD	3A3-1115-1
6	2	PIVOT PIN	3A08702-006
7	1	PULLEY	MS20219-2
8	1	BOLT	AN4-10A
9	2	WASHER	NAS1149F0463P
10	2	WASHER	NAS1149F0432P
11	1	NUT	NAS679A4W
12	1	PLACARD	3A3-1115-2
13	1	BRACKET	3A08003-015
14	1	BRACKET	3A08003-016
15	1	SWIVEL	4A08506-002
16	2	RIVET	AN470AD4
17	1	HANDLE	3A08414-001
18	1	PLACARD	3A3-1115-3
19	1	COTTER PIN	MS24665-285
20	1	RETRACT CABLE ASS'Y	21A08000-137

WIPLINE MODEL 2100 FLOAT PARTS MANUAL

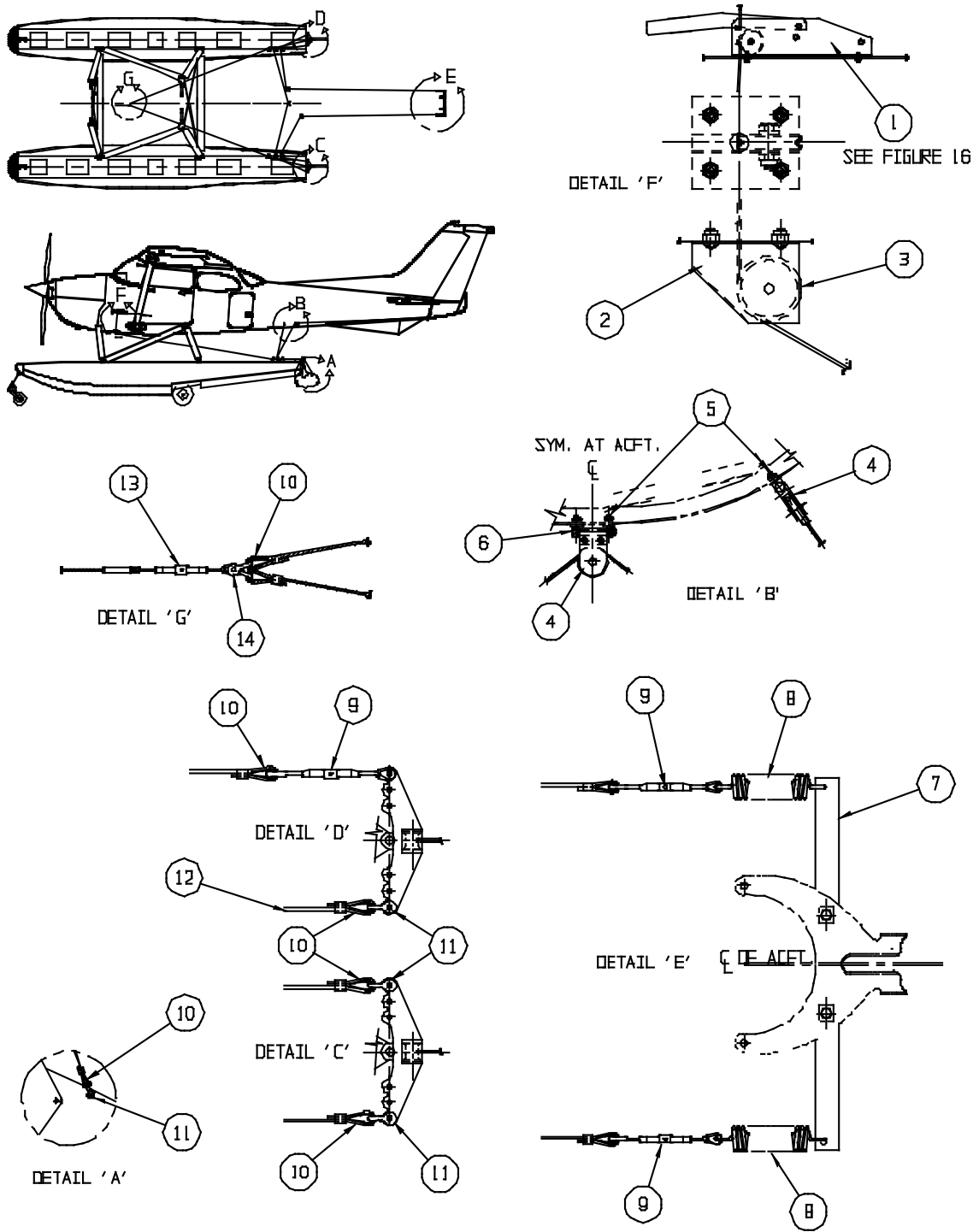

INSTALLATION – STEERING AND RETRACT SYSTEM  
FIGURE 18

WIPLINE MODEL 2100 FLOAT PARTS MANUAL

INSTALLATION – STEERING AND RETRACT SYSTEM, FIGURE 18

<u>REF NO.</u>	<u>NO. REQ.</u>	<u>PART DESCRIPTION</u>	<u>PART NO.</u>
1	1	ASSY. – RETRACT HANDLE (SEE FIGURE 17 FOR BREAKDOWN)	21A08000-128
	4	SCREW - ATTACH	AN526-1032R8
	4	WASHER	NAS1149D0363J
	4	NUT	MS21044N3
2	1	PULLEY BRACKET	3A08151-046
	4	SCREW – ATTACH	AN526-1032R8
	4	WASHER	NAS1149D0363J
	4	NUT	MS21044N3
3	1	PULLEY	MS20219-2
	1	BOLT	AN4-7A
	2	WASHER	NAS1149D0463J
	1	NUT	MS21044N4
4	3	ASSY. – PULLEY BRACKET	21A08000-125
	1	BRACKET	21A08008-150
	1	SPACER - BLOCK	21A08230-002
	1	PULLEY	MS20219-2
	1	BOLT	AN4-7A
	1	WASHER	NAS1149D0363J
	1	WASHER	NAS1149D0416J
	1	NUT	MS21044N4
5	6	EYE BOLT	AN42B4A
	6	WASHER	NAS1149D0363J
	6	NUT	MS21044N3
6	3	BOLT	AN3-17A
	3	WASHER	NAS1149D0363J
	3	NUT	MS21044N3
7	1	EXTENSION – RUDDER HORN	21A08359-201
	2	BOLT – ATTACH	AN3-6A



WIPLINE MODEL 2100 FLOAT PARTS MANUAL

INSTALLATION – STEERING AND RETRACT SYSTEM, FIGURE 18

<u>REF NO.</u>	<u>NO.</u>	<u>REQ.</u>	<u>PART DESCRIPTION</u>	<u>PART NO.</u>
	2		WASHER	NAS1149D0363J
	2		NUT	MS21044N3
8	2		SPRING	21A08525-005
9	3		TURNBUCKLE – BARREL	MS21251B3S
	3		FORK – TERMINAL	MS21252-3RS
	3		PIN ATTACH	MS20392-2-1
	3		PIN – COTTER	MS24665-132
	3		WASHER	NAS1149D0316J
10	10		THIMBLE – CABLE	AN100-3
	10		NICOPRESS – CLAMP	18-2-G
11	5		SHACKLE	MS20115-3
	5		PIN – ATTACH	MS20392-2-11
	5		PIN – COTTER	MS24665-132
12	A/R CABLE (REQUEST LENGTH)			3/32 7X 7 S.S.
13	1		BARREL	MS21251B3S
	1		FORK	MS21252-3RS
14	2		SHACKLE	MS20115-3
	1		PIN – CLEVIS	MS20392-2-19

THIS PAGE INTENTIONALLY LEFT BLANK

WIPLINE MODEL 2100 FLOAT PARTS MANUAL

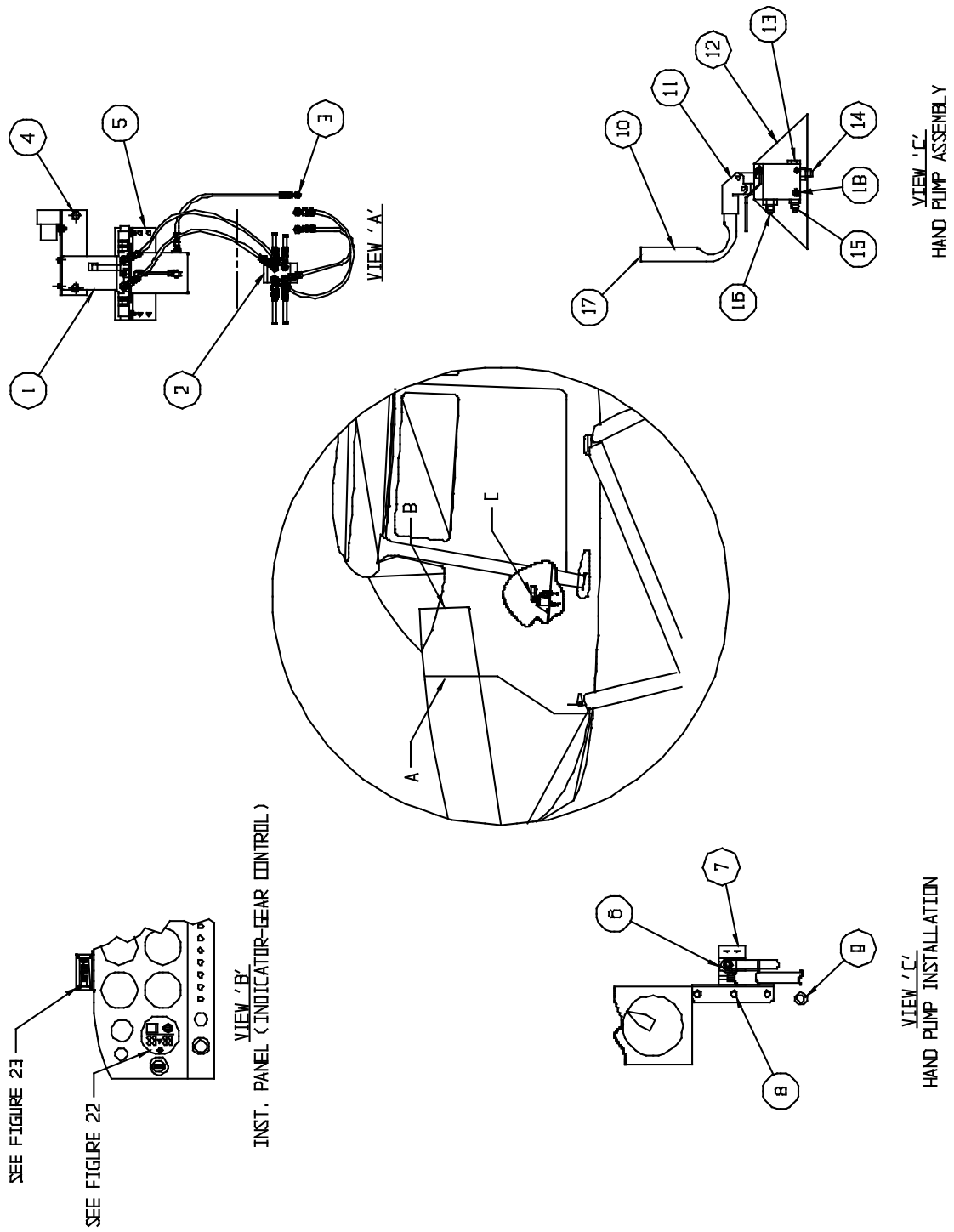

INSTALLATION – HYDRAULIC SYSTEM  
FIGURE 19

WIPLINE MODEL 2100 FLOAT PARTS MANUAL

INSTALLATION – HYDRAULIC SYSTEM, FIGURE 19

<u>REF NO.</u>	<u>NO.</u>	<u>REQ.</u>	<u>PART DESCRIPTION</u>	<u>PART NO.</u>
1	1		ASSY. - HYD PUMP 12V	21A09000-239
	1		ASSY. – HYD PUMP 24V SEE FIGURE 20 (BREAK DOWN)	21A09000-283
2	1		ASSY. – MANIFOLD	21A09000-240
	1		MANIFOLD	6A09046-001
	4		NIPPLE – FITTING	AN816-4-4D
	2		BOLT - ATTACH	AN3-5A
	2		WASHER	NAS1149F0363P
	2		NUT	MS21044N3
	4		NIPPLE – FITTING	AN815-4D
3	3		UNION - FIREWALL	AN832-4D
	3		WASHER	NAS1149F0763P
	3		NUT	AN924-4D
4	2		BOLT - TOP BRACKET ATTACH	AN3-4A
	4		WASHER	NAS1149D0363J
5	1		ANGLE – LOWER PUMP ATTACH	21A09348-020
	4		BOLT	AN3-4A
	4		WASHER	NAS1149D0363J
	4		NUT	MS21044N3
6	1		ASSY. – HAND PUMP	21A09000-194
7	1		ASSY. – PLACARD	21A09000-265
8	3		BOLT – ATTACH	AN3-4A
	3		WASHER	AN970-3
	3		WASHER	NAS1149D0363J
	3		NUT	MS21044N3
9	1		GROMMET	MS35489-49
10	1		HANDLE	21A09396-001

WIPLINE MODEL 2100 FLOAT PARTS MANUAL  
 INSTALLATION – HYDRAULIC SYSTEM, FIGURE 19

<u>REF NO.</u>	<u>NO.</u>	<u>REQ.</u>	<u>PART DESCRIPTION</u>	<u>PART NO.</u>
11	1		HAND PUMP (ONLY)	642873
12	1		BRACKET – PUMP ATTACH	21A09156-129
13	1		PLUG	AN814-4D
	1		“O” RING	MS28775-012
14	1		UNION	21A09746-001
	1		“O” RING	MS28775-012
15	1		UNION	AN815-4D
	1		“O” RING	MS28775-012
16	1		UNION	AN919-6D
	1		“O” RING	MS28775-014
17	1		CAP PLUG	9283K13
18	2		CAP SCREW – ATTACH	5/16-18 UNC-28 X .63
	2		LOCK WASHER	MS35333-40
	2		WASHER	NAS1149F0563P
19	2		ASSY. – BRAKE LINE (NOT SHOWN)	21A04000-080
	2		FITTING	63-190600-3

THIS PAGE INTENTIONALLY LEFT BLANK

# WIPLINE MODEL 2100 FLOAT PARTS MANUAL

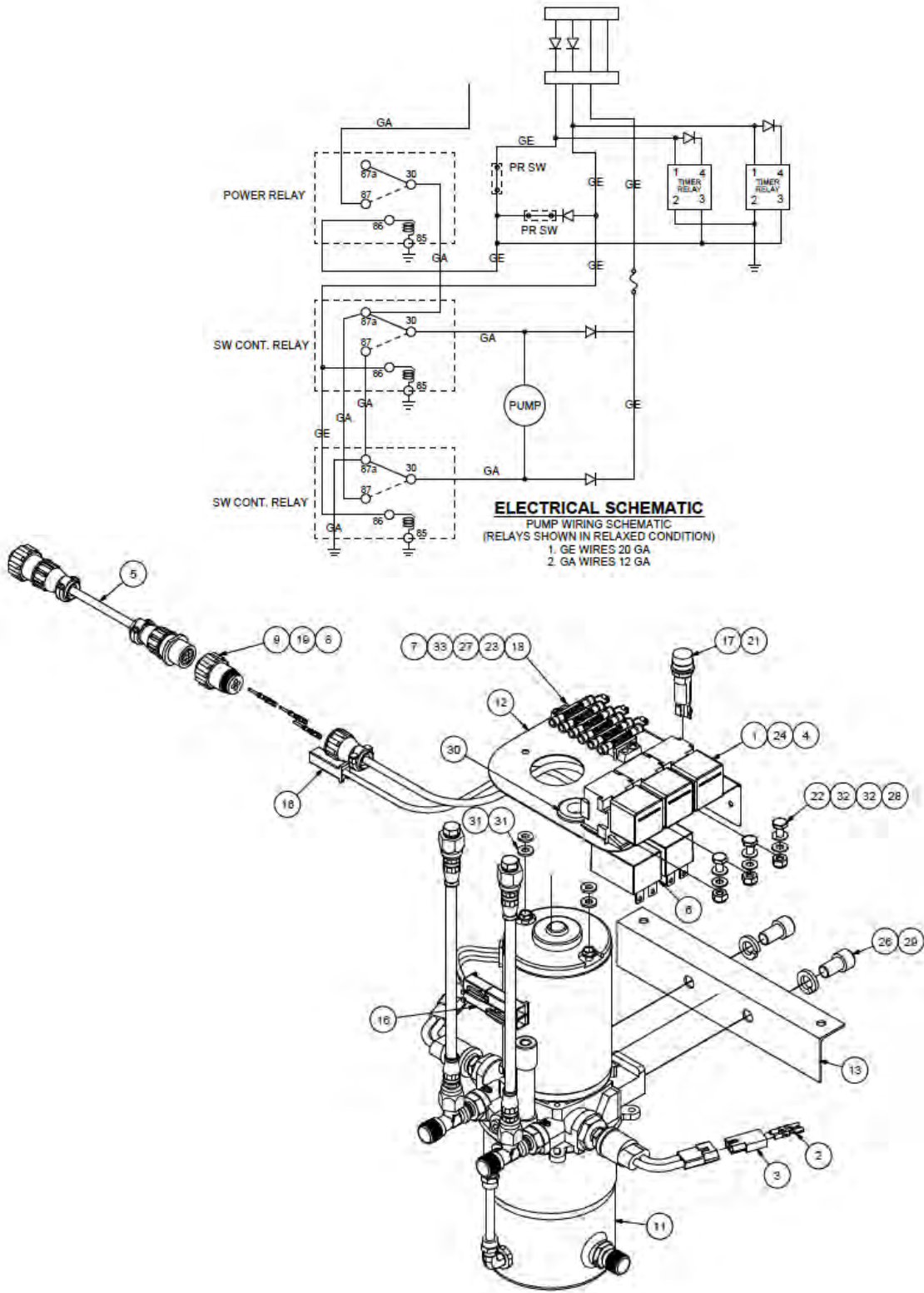

ASSEMBLY – HYDRAULIC PUMP  
 FIGURE 20

WIPLINE MODEL 2100 FLOAT PARTS MANUAL

ASSEMBLY – HYDRAULIC PUMP, FIGURE 20

<u>REF NO.</u>	<u>NO.</u>	<u>PART DESCRIPTION</u>	<u>PART NO.</u>
1	3	RELAY, 12V, 5 PRONG	0-332-209-137
	3	RELAY, 24V, 5 PRONG	0-332-209-211
2	4	PIN, CRIMP FEMALE, 1/8" DIA	02-09-1104
3	2	CONNECTOR PLUG, MALE, 2 CONN.	03-09-1022
4	14	TERMINAL	1-901-355-917
5	1	CABLE, DIODE ADAPTOR	1004949
6	1	TIMER RELAY HARNESS	1005042
7	3	DIODE, 2-1/2"	1N4004
8	2	CLAMP, CABLE, CPC SIZE 11	206062-3
9	1	PLUG, MALE, CPC SIZE 1, 4 PIN	206429-1
10	1	CPC FREE HANG, 4 PIN, FEMALE	206430-2
11	1	ASSEMBLY, HYDRAULIC PUMP, 12V	21A09000-215
	1	ASSEMBLY, HYDRAULIC PUMP, 24V	21A09000-282
12	1	SUPPORT, HYD. PUMP ATTCH	21A09005-264
13	1	ANGLE, MOUNTING, HYD. PUMP	21A09352-030
14	6 FT	WIRE, 12 AWG, WHITE	22759-16-12-9
15	10.1 FT	WIRE, 20 AWG, WHITE	22759-16-20-9
16	3	HOUSING CONNECTOR ASSEMBLY	2601048-200
17	1	FUSE HOLDER	3453LF2A
18	1	TERMINAL BLOCK, 6 CONNECTOR	6-140
19	3	PIN, CRIMP SOCKET, 24-20G	66103-4
20	3	CRIMP SOCKET, FEMALE	66105-4
21	1	FUSE, 250V, (S2565-1)	AGC-1
22	3	BOLT	AN3-3A



WIPLINE MODEL 2100 FLOAT PARTS MANUAL

ASSEMBLY – HYDRAULIC PUMP, FIGURE 20

<u>REF NO.</u>	<u>NO.</u>	<u>REQ.</u>	<u>PART DESCRIPTION</u>	<u>PART NO.</u>
23	2		SCREW, MACHINE, TRUSS HEAD	AN526-632R8
24	3		SOCKET, 5 PRONG, PLASTIC	BR05FW
25	1.5 FT		HEAT SHRINK, TUBING, BLACK	HS105-3/16-0
26	2		SOCKET HEAD CAP SXREW	MS16997-96
27	2		NUT	MS21044N06
28	3		NUT	MS21044N3
29	2		WASHER, SPLIT	MS35338-46
30	1		GROMMET, RUBBER	MS35489-14
31	4		WASHER	NAS1149D0363J
32	6		WASHER	NAS1149F0332P
33	12		RING CONNECTOR	R-3

THIS PAGE INTENTIONALLY LEFT BLANK

WIPLINE MODEL 2100 FLOAT PARTS MANUAL

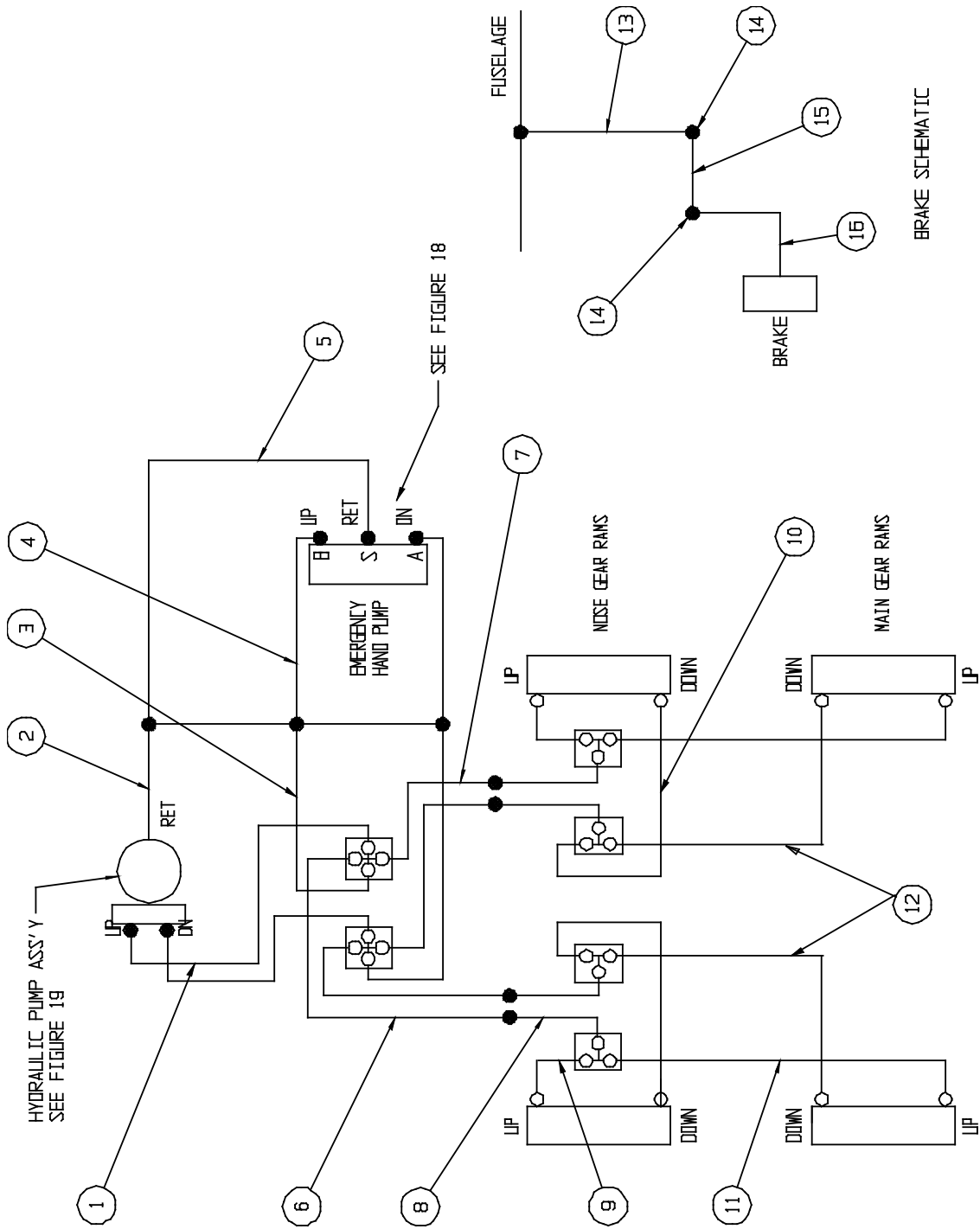

HYDRAULIC SCHEMATIC  
FIGURE 21

WIPLINE MODEL 2100 FLOAT PARTS MANUAL

HYDRAULIC SCHEMATIC, FIGURE 21

<u>REF NO.</u>	<u>NO.</u>	<u>PART DESCRIPTION</u>	<u>PART NO.</u>
1	2	ASSY. – HYDRAULIC HOSE	21A09000-197
2	1	ASSY. – HYDRAULIC HOSE	21A09000-201
3	2	ASSY. – HYDRAULIC HOSE	21A09000-200
4	2	ASSY. – HYDRAULIC HOSE	21A09000-202
5	1	ASSY. – HYDRAULIC HOSE	21A09000-203
6	2	ASSY. – HYDRAULIC HOSE	21A09000-198
7	2	ASSY. – HYDRAULIC HOSE	21A09000-199
8	4	ASSY. – HYDRAULIC HOSE	21A09000-222
9	2	ASSY. – HYDRAULIC HOSE	21A09000-218
10	2	ASSY. – HYDRAULIC HOSE	21A09000-219
11	2	ASSY. – HYDRAULIC HOSE	21A09000-220
12	2	ASSY. – HYDRAULIC HOSE	21A09000-221
13	2	ASSY. – HYDRAULIC HOSE	21A04000-080
	2	FITTING – ENDS	63-190600-3
14	2	FITTING – ELBOW	AN833-3D
	4	WASHER	NAS1149D0663J
	2	NUT	AN924-3D
15	2	LINE ASSY. – HARD	21A04000-079
16	2	LINE ASSY. – FLEX	21A04000-078

WIPLINE MODEL 2100 FLOAT PARTS MANUAL

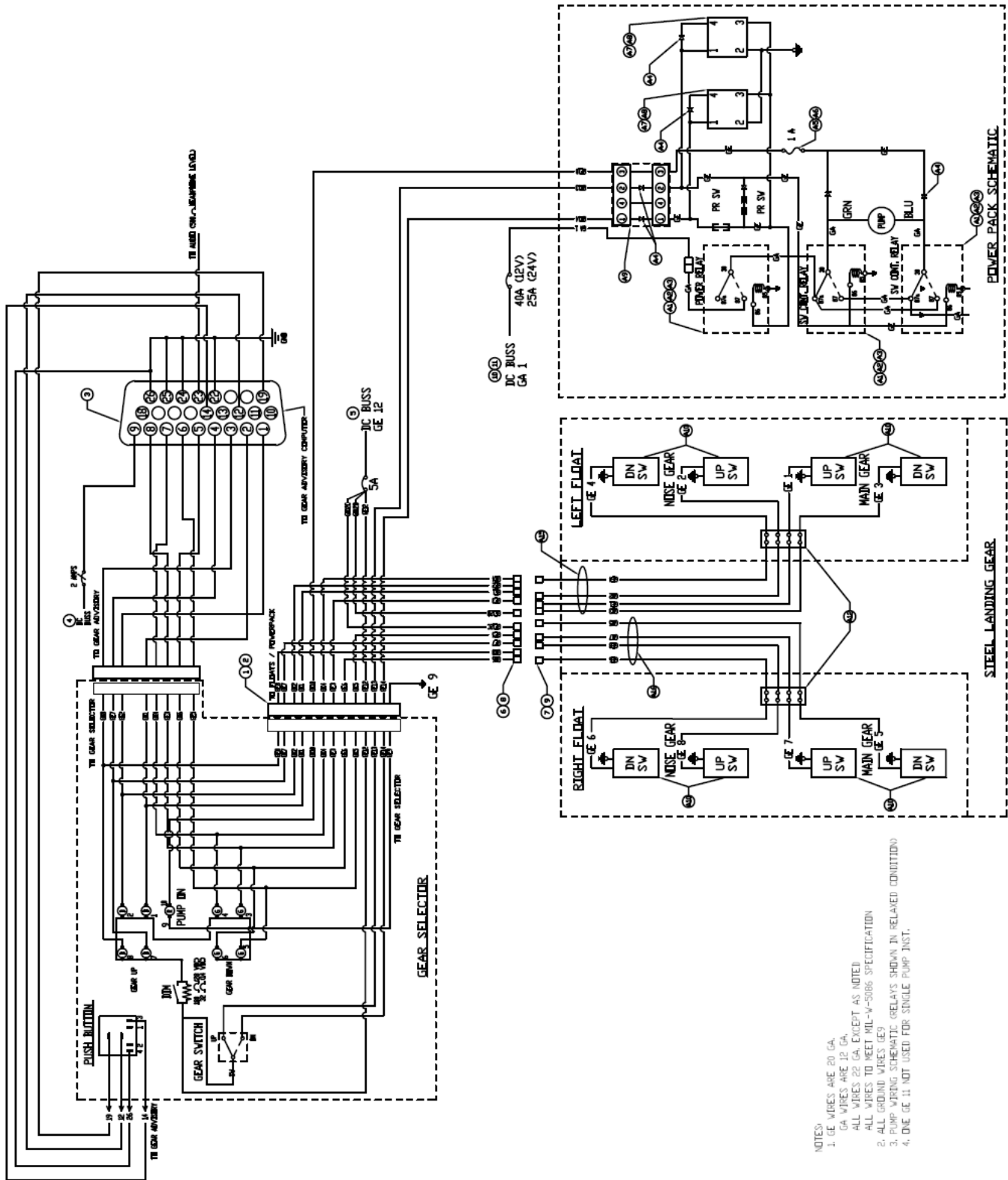

- NOTES:
1. GE WIRES ARE 20 GA.
  - GA WIRES ARE 12 GA.
  - ALL WIRES 22 GA. EXCEPT AS NOTED
  - ALL WIRES TO MEET MIL-V-5086 SPECIFICATION
  2. ALL GROUND WIRES (GE 9)
  3. PUMP WIRING SCHEMATIC (RELAYS SHOWN IN RELAYED CONDITION)
  4. DNE GE 11 NOT USED FOR SINGLE PUMP INST.

ELECTRICAL SCHEMATIC  
FIGURE 22

WIPLINE MODEL 2100 FLOAT PARTS MANUAL

ELECTRICAL SCHEMATIC, FIGURE 22

<u>REF NO.</u>	<u>NO.</u>	<u>REQ.</u>	<u>PART DESCRIPTION</u>	<u>PART NO.</u>
1	1		ASSY, WIRING HARNESS, GEAR SELECTOR	4A11000-011
3	1		ASSY, WIRING HARNESS, GEAR ADVISORY	4A11000-014
4	1		BREAKER, CIRCUIT, KLIXON, 2AMP	7277-2-2
5	1		BREAKER, CIRCUIT, KLIXON, 5AMP	7277-2-5
6	8		PIN	S1635-1SF
7	8		SOCKET	S1636-1
8	8		HOUSING	S1637-1
9	8		HOUSING	S1637-2
10	1		BREAKER, CIRCUIT, 25AMP	W-23- X1A1G-25
11	1		BREAKER, CIRCUIT, 40AMP	W-23-X1A1G-40
A1	3		RELAY 12V	0-332-209-211
A2	3		RELAY 24V	0-332-209-137
A3	3		RELAY SOCKET	BR05FW'
A4	7		DIODE	1N4004
A5	1		FUSE 1 AMP	AGC-1
A6	1		FUSE HOLDER	3453LF2A
A7	2		ASSEMBLY, TIMER RELAY 12V	1005042
A9	1		DIODE CABLE ADAPTOR	1004949
A10	8		SWITCH, 2 WIRE	5801
A12	2		ELECTRICAL TERMINAL, 4 CONNECT	4-140
A15	1		HARNESS W'IRE, FLOATS LT	6A10000-004
A16	1		HARNESS W'IRE, FLOATS, RT	6A10000-005

# WIPLINE MODEL 2100 FLOAT PARTS MANUAL

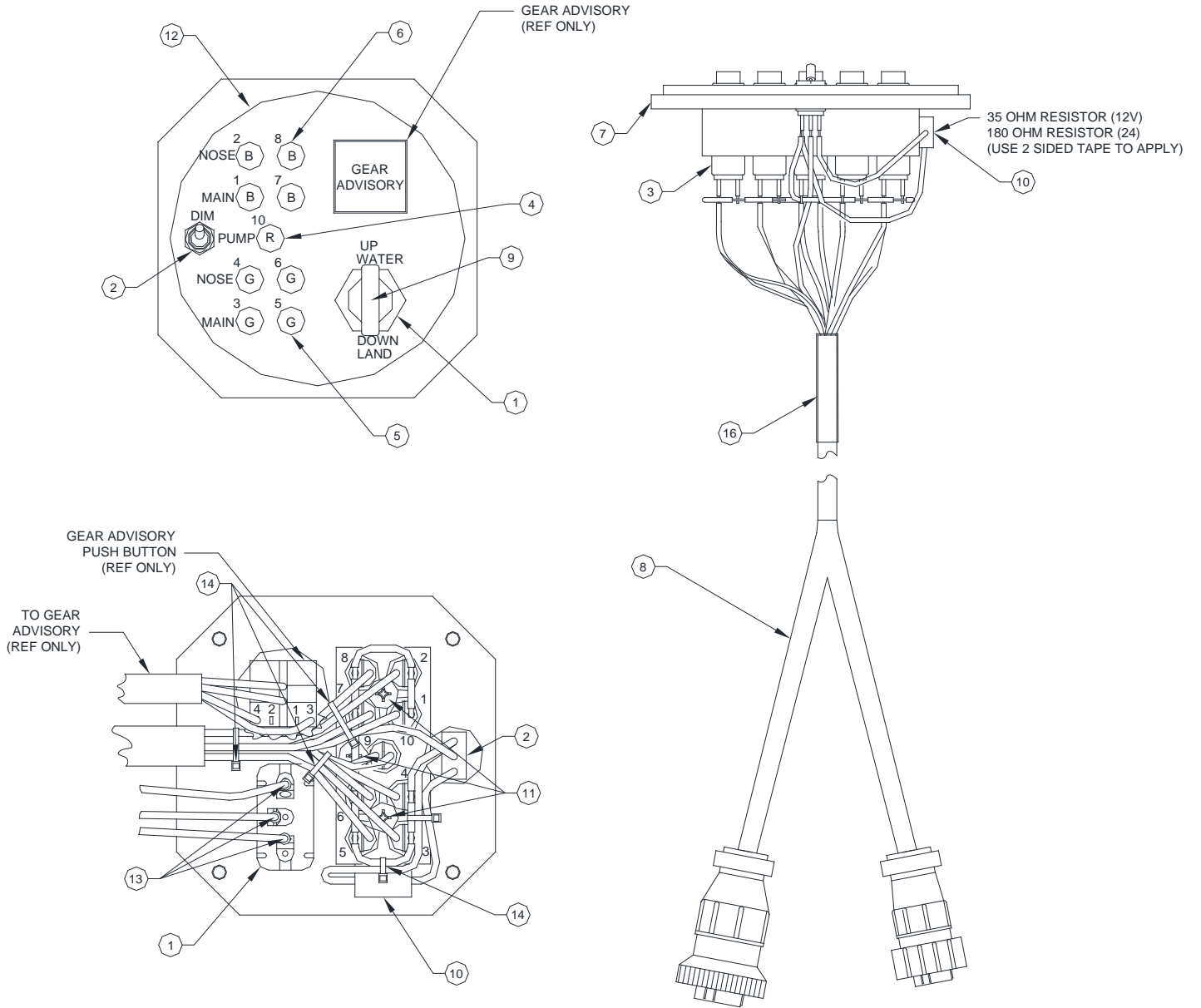

GEAR CONTROL (ROUND)  
FIGURE 23

## WIPLINE MODEL 2100 FLOAT PARTS MANUAL

## GEAR CONTROL (ROUND), FIGURE 23

<u>REF NO.</u>	<u>NO.</u>	<u>REQ.</u>	<u>PART DESCRIPTION</u>	<u>PART NO.</u>
	1		GEAR SELECTOR ASSY. ROUND (12V)	21A11000-009
	1		GEAR SELECTOR ASSY. ROUND (24V)	21A11000-019
1	1		SWITCH	8857K44
2	1		TOGGLE SWITCH, SPDT, ON-ON	A101SYCB
3	9		SOCKET	515-0012
4	1		INDICATOR LAMP, 14V, RED	507-3914-1431-600
	1		INDICATOR LAMP, 28V, RED	507-3918-1431-600
5	4		INICATOR LAMP, 14V, GREEN	507-3914-1432-600
	4		INICATOR LAMP, 28V, GREEN	507-3918-1432-600
6	4		INDICATOR LAMP, 14V, BLUE	507-3914-1434-600
	4		INDICATOR LAMP, 28V, BLUE	507-3918-1434-600
7	1		BLOCK, GEAR CONTROL	21A11179-001
8	1		HARNESS ASSEMBLY, GEAR SELECTOR	4A11000-008
9	1		GEAR SWITCH KNOB	21A11259-003
10	1		RESISTOR, 14V, DALE RH5 5W	RH-5-35
	1		RESISTOR, 28V, DALE RH5 5W	RH-5-180
11	3		SCREW, TRUSS HEAD, 6-32	AN526-632R8
12	1		PLACARD, ROUND2100 GEAR SELECTOR	10B3-6202
13	3		RING CONNECTOR, #6, 20 AWG, RED	R-3
14	5		CABLE TIE	PLT1M-M
15	16"		SHRINK WRAP, 3/16, WHITE	HIXR-3/16
16	3"		HEAT SHRINK TUBING	HS105-1/2-0
17	6"		WIRE, 20AWG, WHITE	22759-16-20-9



WIPLINE MODEL 2100 FLOAT PARTS MANUAL

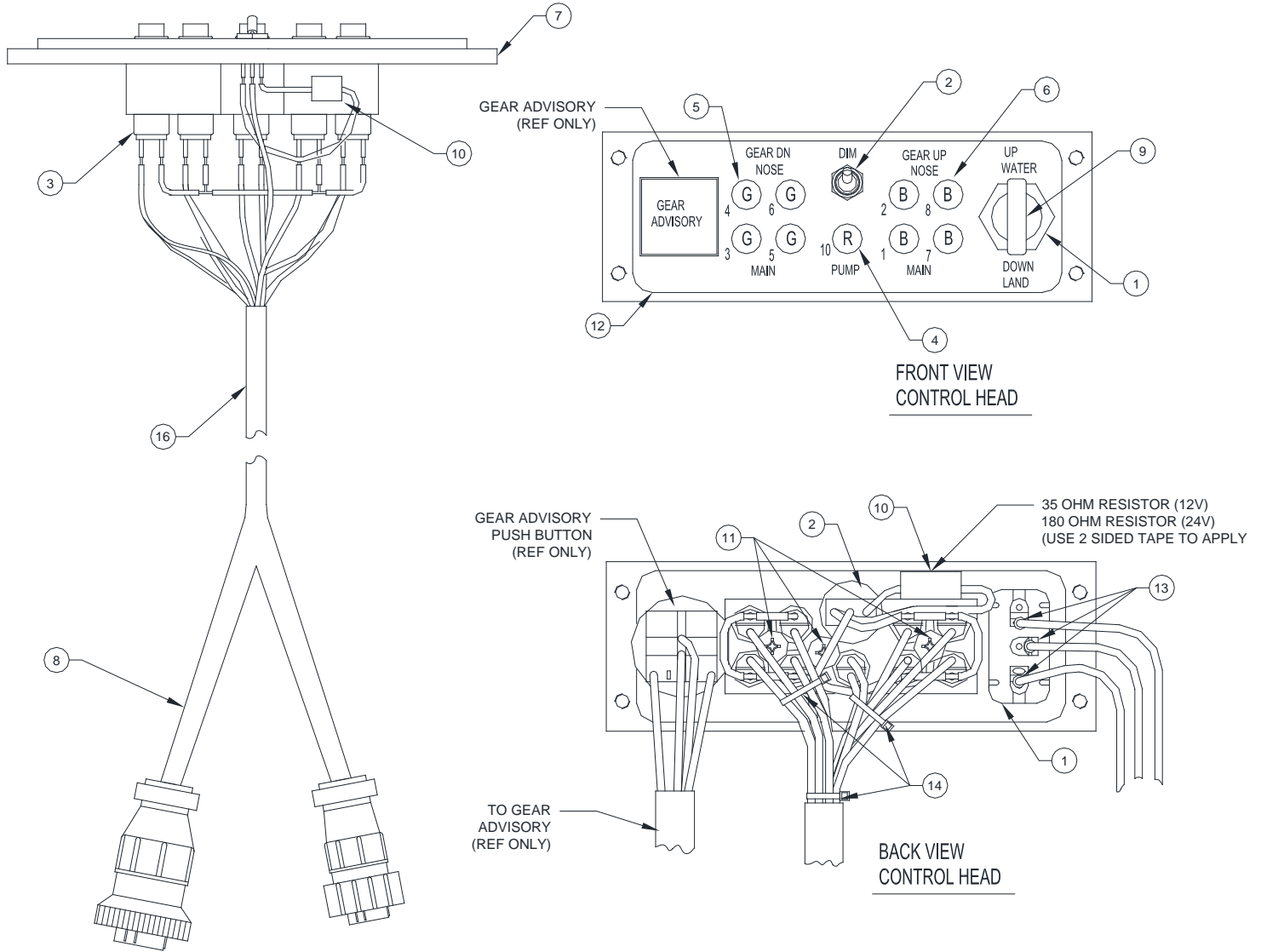

GEAR CONTROL (RECTANGLE)  
FIGURE 24

WIPLINE MODEL 2100 FLOAT PARTS MANUAL

GEAR CONTROL (RECTANGLE), FIGURE 24

<u>REF NO.</u>	<u>NO.</u>	<u>REQ.</u>	<u>PART DESCRIPTION</u>	<u>PART NO.</u>
	1		GEAR SELECTOR ASSY. RECTANGLE (12V)	21A11000-010
	1		GEAR SELECTOR ASSY. RECTANGLE (24V)	21A11000-018
1	1		SWITCH	8857K44
2	1		TOGGLE SWITCH, SPDT, ON-ON	A101SYCB
3	9		SOCKET	515-0012
4	1		INDICATOR LAMP, 14V, RED	507-3914-1431-600
	1		INDICATOR LAMP, 28V, RED	507-3918-1431-600
5	4		INICATOR LAMP, 14V, GREEN	507-3914-1432-600
	4		INICATOR LAMP, 28V, GREEN	507-3918-1432-600
6	4		INDICATOR LAMP, 14V, BLUE	507-3914-1434-600
	4		INDICATOR LAMP, 28V, BLUE	507-3918-1434-600
7	1		BLOCK, GEAR CONTROL	21A11179-002
8	1		HARNESS ASSEMBLY, GEAR SELECTOR	4A11000-008
9	1		GEAR SWITCH KNOB	21A11259-003
10	1		RESISTOR, 14V, DALE RH5 5W	RH-5-35
	1		RESISTOR, 28V, DALE RH5 5W	RH-5-180
11	3		SCREW, TRUSS HEAD, 6-32	AN526-632R8
12	1		PLACARD, RECTANGLE 2100 GEAR SELECTOR	10B3-6277
13	3		RING CONNECTOR, #6, 20 AWG, RED	R-3
14	3		CABLE TIE	PLT1M-M
15	16"		SHRINK WRAP, 3/16, WHITE	HIXR-3/16
16	3"		HEAT SHRINK TUBING	HS105-1/2-0
17	6"		WIRE, 20AWG, WHITE	22759-16-20-9

WIPLINE MODEL 2100 FLOAT PARTS MANUAL

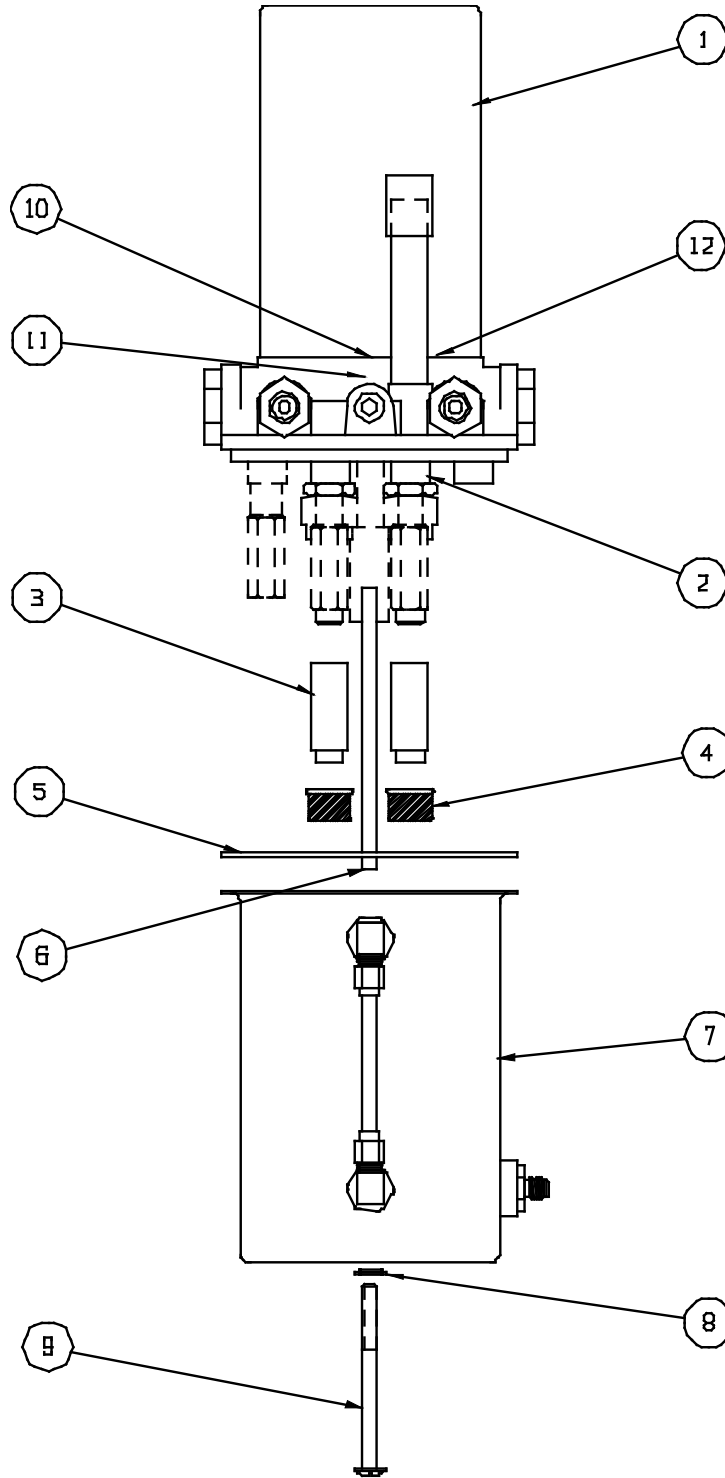

HYDRAULIC PUMP  
FIGURE 25

## WIPLINE MODEL 2100 FLOAT PARTS MANUAL

## HYDRAULIC PUMP, FIGURE 25

<u>REF NO.</u>	<u>NO.</u>	<u>REQ.</u>	<u>PART DESCRIPTION</u>	<u>PART NO.</u>
1	1		HYDRAULIC PUMP ASSY. (12V)	21A09000-215
			HYDRAULIC PUMP ASSY. (24V)	21A09000-282
			MOTOR (12V)	640661
			MOTOR (24V)	641131
2	1		BASIC PUMP	634873
3	2		TUBE EXTENSIONS	362136
4	2		FILTER	410521
5	1		SEAL RESERVIOR	410578
6	1		RETURN TUBE	365047
7	1		RESERVIOR – GAUGE ASSY.	775260
8	1		SEAL THREAD	415067
9	1		SCREW – RESERVIOR ATTACH	409715
10	1		COUPLING – MOTOR TO PUMP	361183
11	1		SEAL – PUMP SHAFT	410512
12	1		“O” RING MOTOR TO BASE	405673