



WIPLINE FLOATS • SKIS • MODIFICATIONS • AIRCRAFT SALES
AVIONICS • INTERIOR • MAINTENANCE • PAINT REFINISHING

SERVICE LETTER 185

10000 Nutplate Installation

Aircraft Makes/Model(s):	Float Model(s):	Compliance: Optional	By: MAB
AT-802 AT-802A	10000A	Part Number: 1009886	Approved: SDW
		Date: 6/6/2019	Revision: B

LOG OF REVISIONS

Revision	Description	Date
A	Initial release	5/9/2019
B	Updated drawings and work instruction.	6/6/2019

FAA approval has been obtained for technical data in this publication that affects STC or TSO design compliance.



EFFECTIVITY:

This service letter applies to Air Tractor AT-802 and AT-802A models with Wipline 10000 Amphibious Floats installed per STC SA01795CH.

COMPLIANCE:

Optional compliance

BACKGROUND:

Traditionally, the scoop tunnel on the Air Tractor uses nuts, washers, and bolts. Due to tight quarters, it is difficult to access when performing maintenance. This service letter provides a nutplate strip installation for easier maintenance in the future.

COMPLIANCE METHOD:

Optional

APPROXIMATE SHOP HOURS:

Installing the nutplate strip will take approximately 2 hours per float set, recommend installing nutplates when performing maintenance to the scoop tunnel.

1700 Henry Ave - Fleming Field (KSGS), South St. Paul, MN 55075

Phone: 651.451.1205 | Fax: 651.457.7858

www.wipaire.com

WARRANTY INFORMATION:

This service letter does not include warranty for parts or labor.

TECHNICAL DATA:

Copies of this service letter, associated service kit (if applicable), float service manual, and float parts manual are available at www.wipaire.com.

ITEMS PROVIDED IN SERVICE KIT 1009886-01 (1 SET OF FLOATS)

ITEM	QTY	PART NUMBER	DESCRIPTION
1	4	1009724	ASSEMBLY, STRIP, NUTPLATE, 10000
2	4	1009725	ASSEMBLY, STRIP, NUTPLATE, 10000

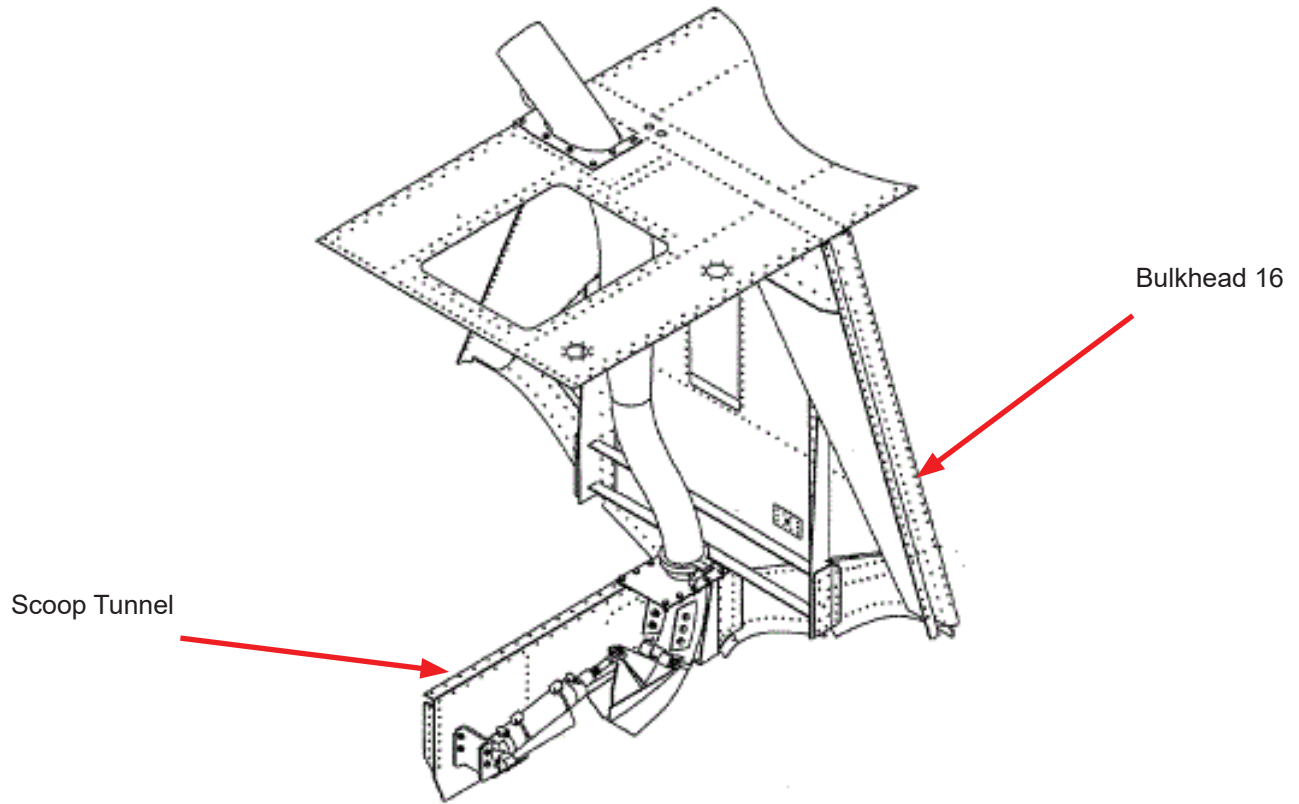
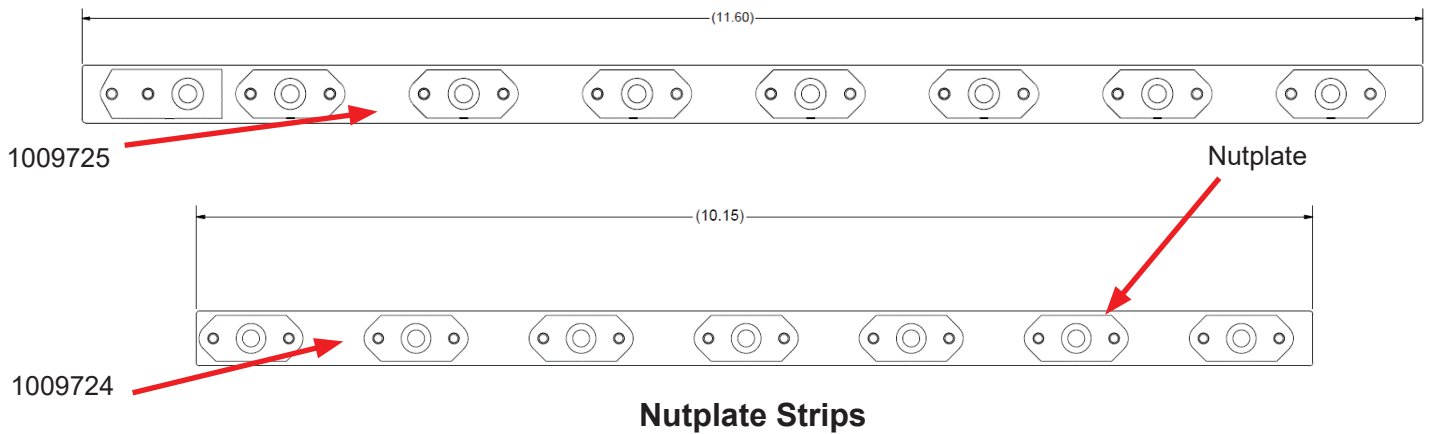

Scoop Tunnel

WORK INSTRUCTION

1. Access scoop tunnel through aft panel in foam/baggage compartment.
2. Remove hardware and covers on top of scoop tunnel.
3. Discard hardware (nuts and washers) on bottom of scoop tunnel flange.
4. Clean sealant from covers and top and bottom of flanges.
5. Reinstall covers with PR-1422 or equivalent using nutplate strips on bottom and existing bolts and washers.
Note: 1009724 (10.15") goes forward and 1009725 (11.60") goes aft.
6. Leak check scoop tunnels.

Scoop Tunnel

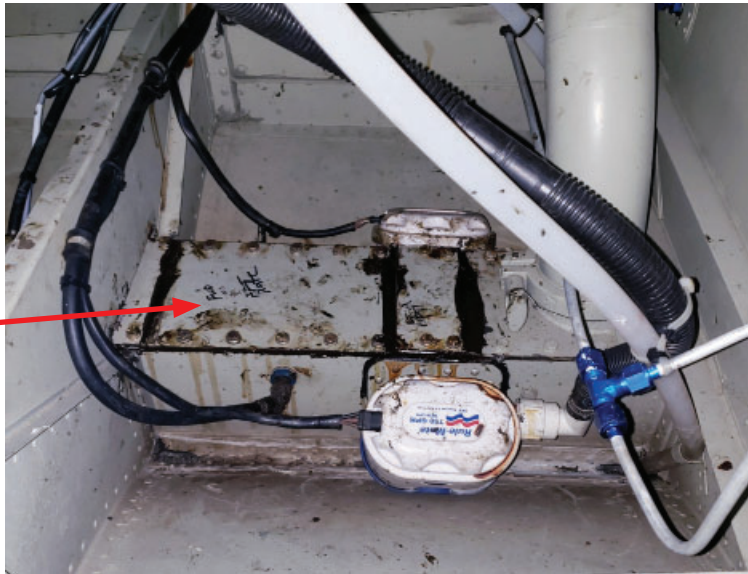

Nutplate Strip



AIRCRAFT CLOSING AND RETURN TO SERVICE

1. Upon completion of inspection, enter information in Aircraft Logbook for completion of this Wipaire service letter.