



WIPLINE FLOATS • SKIS • MODIFICATIONS • AIRCRAFT SALES  
AVIONICS • INTERIOR • MAINTENANCE • PAINT REFINISHING

## SERVICE LETTER 191

### FIRE BOSS WATER SCOOP SWITCH REPLACEMENT

<b>Aircraft Makes/Model(s):</b>	<b>Float Model(s):</b>	<b>Compliance:</b> As required	<b>By:</b> MAB
AT-802 & AT-802A	10000A	<b>Part Number:</b> 1009904	<b>Approved:</b> SDW
		<b>Date:</b> 6/11/2019	<b>Revision:</b> B

#### LOG OF REVISIONS

Revision	Description	Date
A	Initial release	5/9/2019
B	Updated Work Instructions	6/11/2019

FAA approval has been obtained for technical data in this publication that affects STC or TSO design compliance.

#### EFFECTIVITY:

This service letter applies to Air Tractor AT-802 and AT-802A with Wipline 10000 Amphibious floats installed per STC SA01795CH prior to float serial numbers 10205A/10206A.

#### COMPLIANCE:

As required. This is a repair option to replacing the water scoop switches.

#### BACKGROUND:

The originally installed water scoop switch assemblies may have issues with water contamination of the various connectors. The new method utilizes parts with molded connectors more suitable for prolonged water exposure.

#### COMPLIANCE METHOD:

Remove existing water scoop switches and replace with new style switch assemblies as per this Service Letter.

#### APPROXIMATE SHOP HOURS:

Removal and replacement of the existing water scoop switches will require 8 hours per float.

#### WARRANTY INFORMATION:

This service letter does not include warranty for labor.

#### TECHNICAL DATA:

Copies of this service letter, associated service kit (if applicable), float service manual, and float parts manual are available at [www.wipaire.com](http://www.wipaire.com).

1700 Henry Ave – Fleming Field (KSGS), South St. Paul, MN 55075

Ph: 651.451.1205 Fax: 651.457.7858

[www.wipaire.com](http://www.wipaire.com)

**ITEMS PROVIDED IN SERVICE KIT 1009904-01 (2 FLOATS)**

ITEM	QTY	PART NUMBER	DESCRIPTION
1	2	1009903	ASSEMBLY, SCOOP HARNESS ADAPTER
2	4	M6965106	ASB-6 STRAP
3	2	NAS1149D0963J	WASHER, 0.578 ID, 0.063 THK, ALUMINUM
4	4	S4685792	SENSOR, INDUCTIVE MAGNET, 10-30 VDC
5	4	S6913351	CORD SET
6	2	U0163-11	SPLITTER, 2 BRANCH, 4 WIRE, MALE
7	20	PLT2S-M	CABLE-TIE, PLASTIC, WHITE, 7.5"

**WORK INSTRUCTION**

1. Gain access to water scoop system baggage area from aft bulkhead panel. Then remove water scoop tunnel covers.

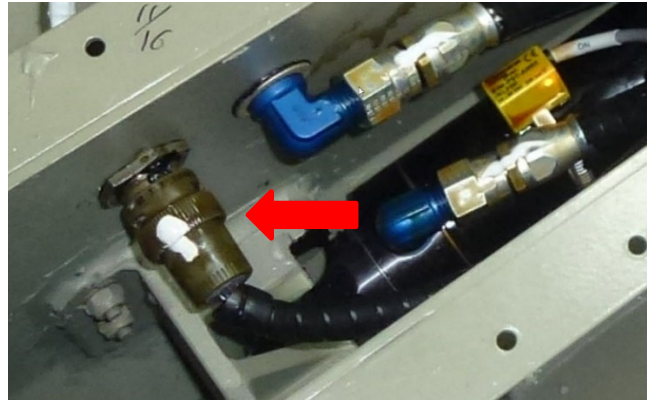

2. Remove hydraulic actuator assembly from tunnel to facilitate installation of new switches.
3. Disconnect existing Canon plug from scoop tunnel side wall. Remove and discard switch harness from hydraulic scoop actuator.
4. Connect Cannon plug to new adapter harness (1009903).
5. Zip tie up to existing wires/hydraulic lines.

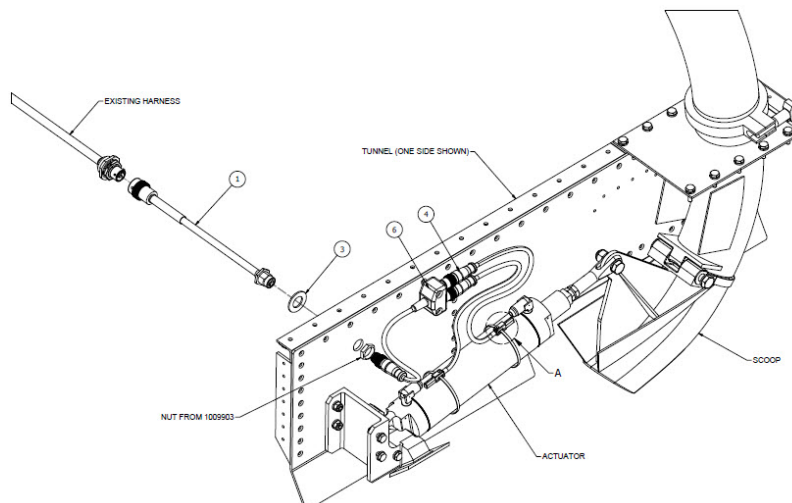

6. If not already done, mark the Splitter 2 Branch 4 Wire (U0163-11) with "DN" at the #1 position, and "UP" at the #2 position. The "UP" Switch will be towards the aft end of the float and the "DN" switch will be towards the fwd end of float.
7. Open up the diameter of the Washer (NAS1149D0963J) to 19/32, to fit Adapter receptacle.
8. Remove Rubber O-Ring from rear mount receptacle of Harness Adapter. Replace with modified Washer.
9. Insert Rear Mount Receptacle of Harness Adapter (1009903) through tunnel access hole from outside. Secure with nut and taper facing inwards (helps to center connector in larger hole). Assemble wet with PR-1422 or equivalent.
10. Ensure connector end and internal area remain free of sealant.
11. Remove left hand screws from Inductive Magnet Sensors (S4685792). Mount switches on scoop hydraulic actuator using ASB-6 Straps (M6965106) and Cord Sets (S693351). See Detail A.
12. Re-install hydraulic actuator assembly with previously removed hardware.
13. Connect corresponding switches to splitter. Connect splitter to bulkhead connector.
14. Secure Splitter Harness and Switch assemblies with Plastic Cable Tie (PLT-25-M).
15. Operational check:
  - a. With scoops in Up position, adjust "UP" Switch forward or aft to make contact. LED will be illuminated.
  - b. With scoops in Down position, adjust "DN" Switch forward or aft to make contact. LED will be illuminated
  - c. **Note:** Ensure the Switch LED comes on at the same time the scoop cylinder bottoms out. Timing of the scoop travel for full up or full down limits should be approximately  $\frac{3}{4}$  of a second.
16. Upon completion of inspection, enter information in Aircraft Logbook for completion of this Wipaire service letter.

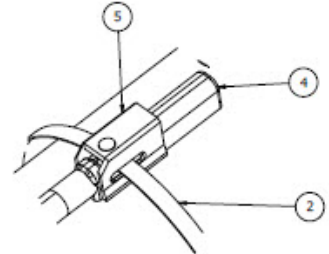

DETAIL A