



WIPLINE FLOATS • SKIS • MODIFICATIONS • AIRCRAFT SALES
AVIONICS • INTERIOR • MAINTENANCE • PAINT REFINISHING

SERVICE LETTER 218

Cessna 208 & 208B Hydraulic Pump Replacement for 8750A Floats

Aircraft Makes/Model(s):	Float Model(s):	Compliance: Optional	By: MAS
Textron Aviation 208, 208B	8750A	Part Number: 1011608	Approved: DRH
		Date: 4/29/2024	Revision: C

LOG OF REVISIONS

Revision	Description	Date
A	Initial release	5/7/2021
B	Added note in Background section for Service Letter 252.	4/11/2023
C	Updated note in Background section about Aero Twin extended baggage.	4/29/2024

FAA approval has been obtained for technical data in this publication that affects STC or TSO design compliance.

EFFECTIVITY:

This service letter applies to Textron Aviation models 208 and 208B with Wipline 8750 Amphibian Floats installed per STC SA1311GL.

COMPLIANCE:

Optional compliance

BACKGROUND:

Bi-Directional Hydraulic Pump Assembly p/n 1004397 has been discontinued. This service letter provides the option to replace it with a new pump p/n 1011436.

Note: To accommodate the new hydraulic pump assembly, reference Service Letter 252 to add additional sight-glass port and larger fill-port access to existing Extended Baggage Cargo assemblies installed per STC SA04388CH. For aircraft equipped with the Aero Twin extended baggage, replace the hydraulic pump cover with Wipaire cover 1011919. Reference Wipaire drawing 1006588.

COMPLIANCE METHOD:

Install provided parts as shown in the Work Instruction section of this service letter.

APPROXIMATE SHOP HOURS:

The work instruction for this service letter will take approximately 8 labor hours.

WEIGHT AND BALANCE CHANGE:

Cessna 208 Only +6.1 lbs, F.S. 286.23

Cessna 208B Only +6.1 lbs, F.S. 334.23

1700 Henry Ave - Fleming Field (KSGS), South St. Paul, MN 55075

Phone: 651.451.1205 | Fax: 651.457.7858

www.wipaire.com

WARRANTY INFORMATION:

This service letter does not include warranty for labor and parts.

TECHNICAL DATA:

Copies of this service letter, associated service kit (if applicable), float service manual, and float parts manual are available at www.wipaire.com.

ITEMS PROVIDED IN SERVICE KIT 1011608-01

ITEM	QTY	PART NUMBER	DESCRIPTION
1	1	1011436	Assembly, Hydraulic Power Pack
2	4	AN4-4A	Bolt, 1/4-28 thread
3	2	S1232-530	Circuit Breaker, 30 amp

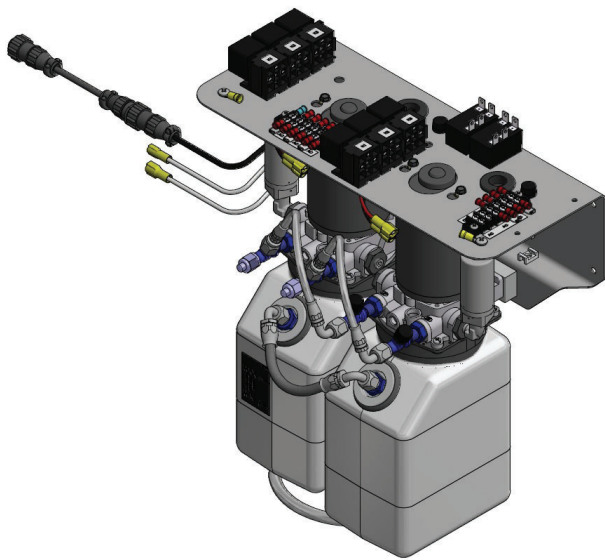

DISCONTINUED

BI-DIRECTIONAL HYDRAULIC PUMP 1004397

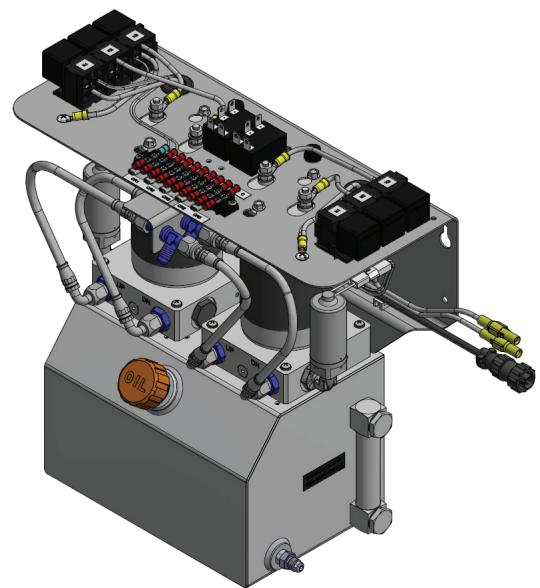

NEW

BI-DIRECTIONAL HYDRAULIC PUMP 1011436

Work Instructions

Cessna 208 Only

1. Disconnect aircraft battery.
2. Disconnect single pin Molex connectors for GA1 and GA4 (12 ga) wire.
3. Disconnect 4 pin CPC connector from hydraulic power pack assembly 1004397.
4. Drain hydraulic fluid from both hydraulic power pack reservoirs.
5. Disconnect and cap 1004089-19 hydraulic line from reservoir to emergency hand pump.
6. Disconnect and cap 1004089-26 hydraulic lines from pump up and dn manifold fittings.

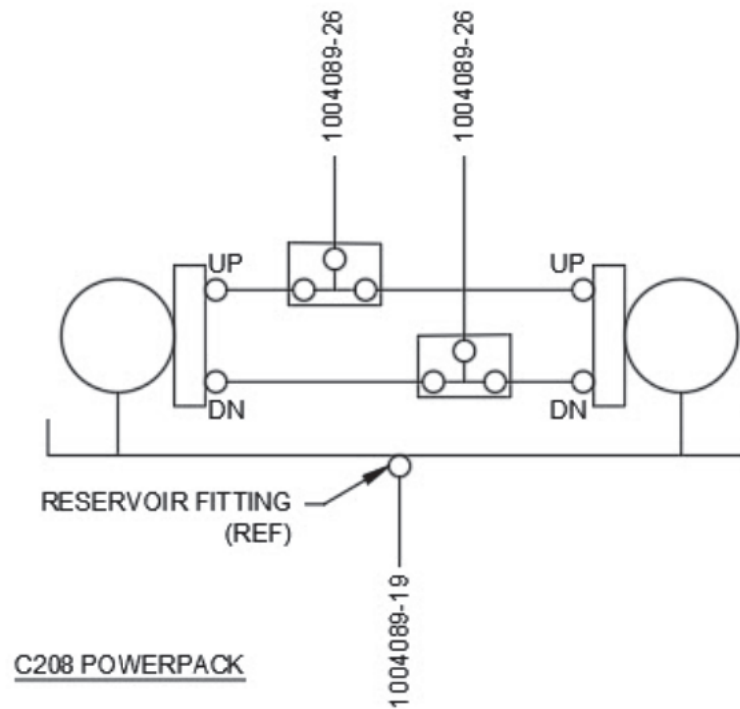

208 Hydraulic Schematic

7. Unbolt and remove hydraulic power pack 1004397 from pump mount assembly.
8. Install new hydraulic power pack 1011436 onto pump mount assembly using supplied bolts and existing washers.
9. Re-install hydraulic lines 1004089-26 onto hydraulic power pack tees.
10. Re-install hydraulic line 1004089-19 onto hydraulic power pack reservoir.
11. Re-install 4 pin CPC connector. See electrical schematic.

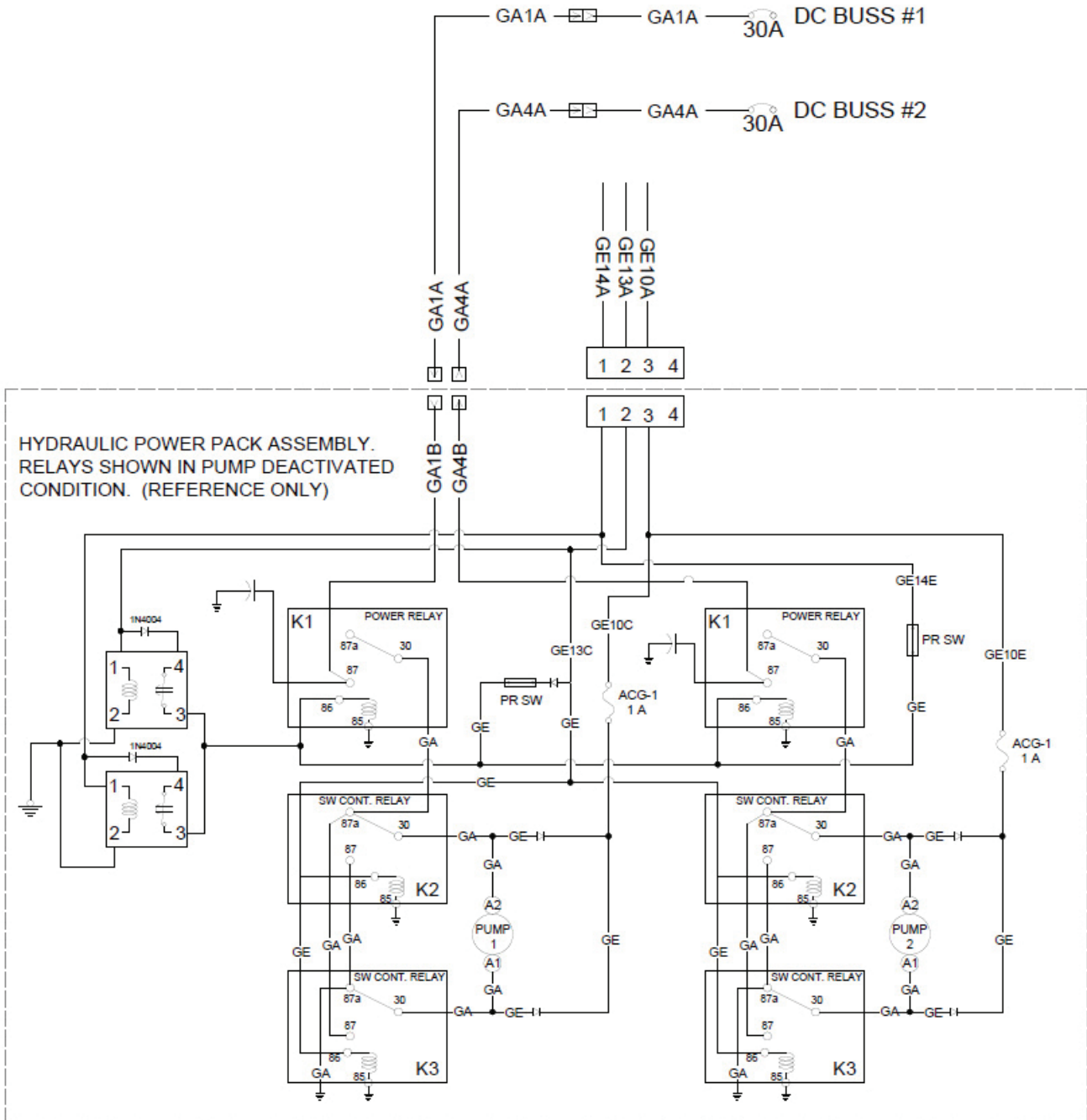

Electrical Schematic

12. Cut single pin Molex connector from GA1 and GA4 (12 ga) wires. Install 73M-250-32NL connector onto GA1 wire and 73F-250-32NL connector onto GA4 wire. Connect GA1 wire to pump 1 and GA4 wire to pump 2. See electrical schematic.
13. Remove two 20 amp Pump 1 and Pump 2 circuit breakers P/N S1232-520 from aircraft circuit breaker panel.
14. Install two 30 amp Pump 1 and Pump 2 circuit breakers P/N S1232-530 into aircraft circuit breaker panel.
15. Reconnect aircraft battery, service pump reservoir with MIL-H-5606 hydraulic fluid, and perform a retraction/extension test to make sure system is functioning correctly. Watch the system for leaks and add MIL-H-5606 hydraulic fluid as needed.

Work Instructions

Cessna 208B Only

1. Disconnect aircraft battery.
2. Disconnect single pin Molex connectors for GA1 and GA4 (12 ga) wire.
3. Disconnect 4 pin CPC connector from hydraulic power pack assembly 1004397.
4. Drain hydraulic fluid from both hydraulic power pack reservoirs.
5. Disconnect and cap 1004089-27 hydraulic line from reservoir to emergency hand pump.
6. Disconnect and cap 1004089-29 hydraulic lines from pump up and dn manifold fittings.

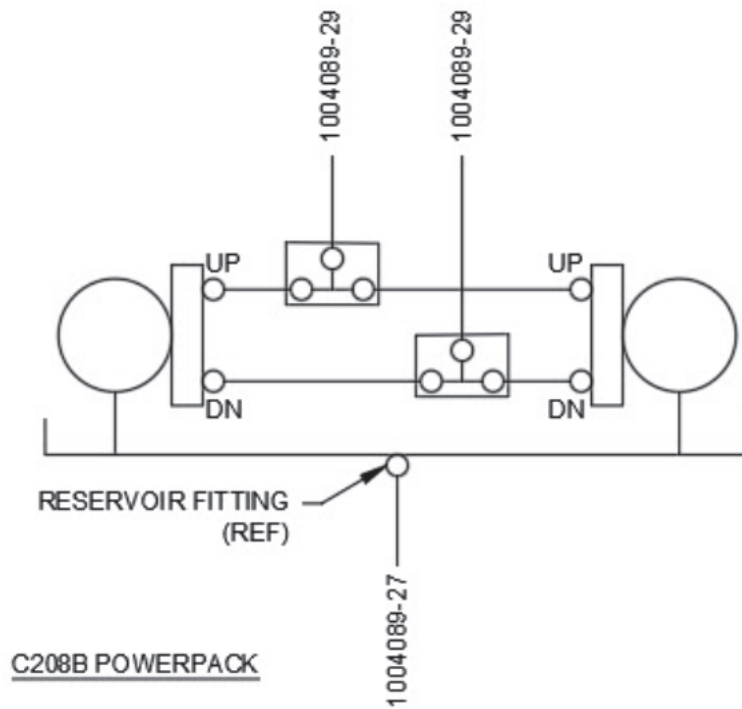

208B Hydraulic Schematic

7. Unbolt and remove hydraulic power pack 1004397 from pump mount assembly.
8. Install new hydraulic power pack 1011436 onto pump mount assembly using supplied bolts and existing washers.
9. Re-install hydraulic lines 1004089-29 onto hydraulic power pack tees.
10. Re-install hydraulic line 1004089-27 onto hydraulic power pack reservoir.
11. Re-install 4 pin CPC connector. See electrical schematic.

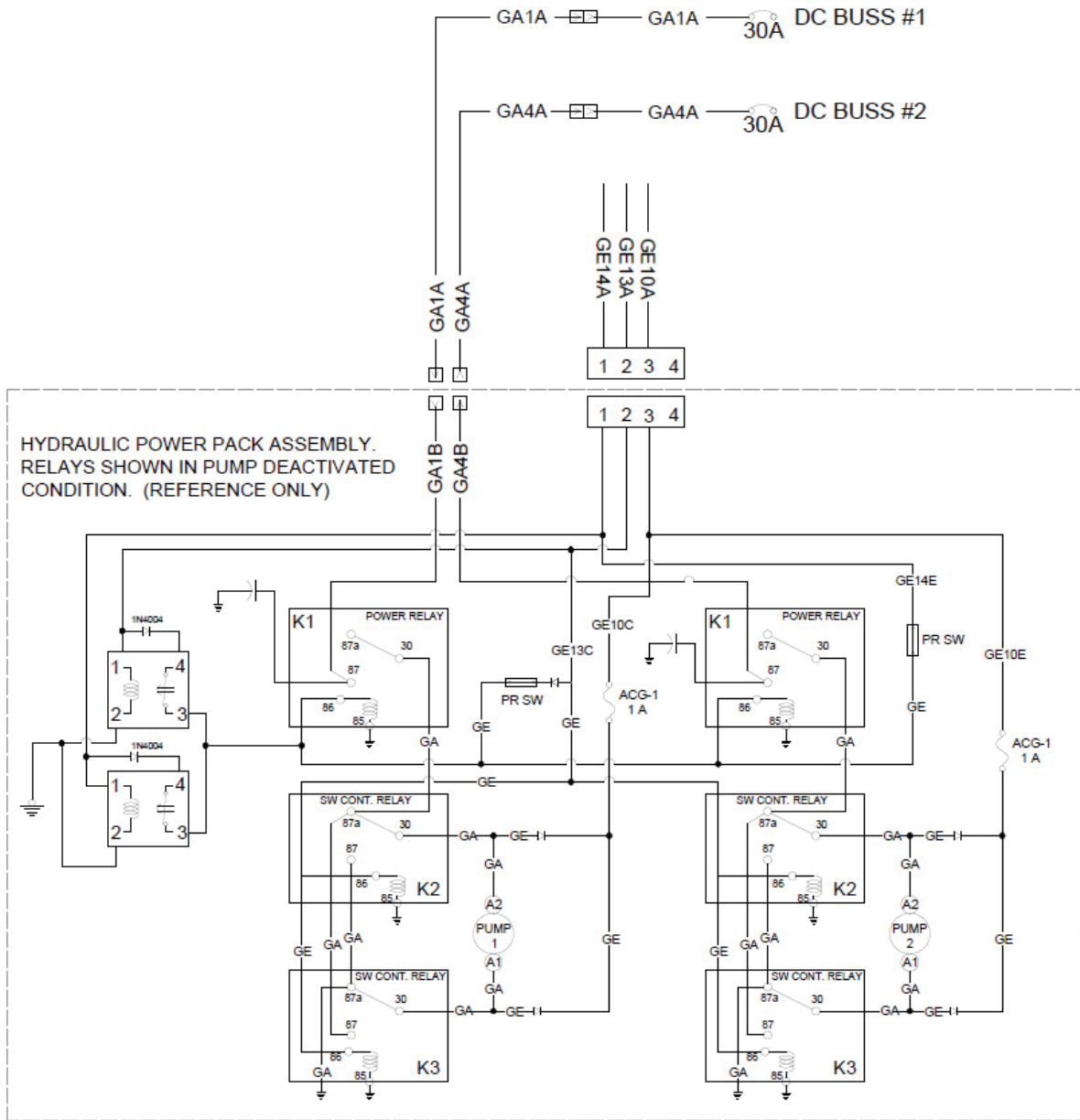

Electrical Schematic

12. Cut single pin Molex connector from GA1 and GA4 (12 ga) wires. Install 73M-250-32NL connector onto GA1 wire and 73F-250-32NL connector onto GA4 wire. Connect GA1 wire to pump 1 and GA4 wire to pump 2. See electrical schematic.
13. Remove two 20 amp Pump 1 and Pump 2 circuit breakers P/N S1232-520 from aircraft circuit breaker panel.
14. Install two 30 amp Pump 1 and Pump 2 circuit breakers P/N S1232-530 into aircraft circuit breaker panel.
15. Reconnect aircraft battery, service pump reservoir with MIL-H-5606 hydraulic fluid, and perform a retraction/extension test to make sure system is functioning correctly. Watch the system for leaks and add MIL-H-5606 hydraulic fluid as needed.

Aircraft Closing & Return to Service

1. Upon completion of inspection, enter information in Aircraft Logbook for completion of Wipaire Service Letter 218.