



WIPLINE FLOATS • SKIS • MODIFICATIONS • AIRCRAFT SALES  
AVIONICS • INTERIOR • MAINTENANCE • PAINT REFINISHING

## SERVICE LETTER 235

### Retention of Fire Boss Hopper Fill Valves

<b>Aircraft Makes/Model(s):</b>	<b>Float Model(s):</b>	<b>Compliance:</b> Optional	<b>By:</b> MAS
Air Tractor AT-802 & AT-802A	10000A	<b>Part Number:</b> 1011930	<b>Approved:</b> DRH
		<b>Date:</b> 5/17/2024	<b>Revision:</b> D

### LOG OF REVISIONS

Revision	Description	Date
A	Initial release	7/13/2021
B	Added strap option, adjusted shop hours, and updated work instructions titles	10/8/2021
C	Updated Effectivity note and Background. Added Options A and B. Updated Option B work instructions. Added Tables 3 and 4. Added Kits 1011930-01 and 1011930-02. Updated Figure 3, removed Figure 4.	7/1/2022
D	Changed screw AN526C1032R18 to AN526C1032R22 in Table 2 and Table 4.	5/17/2024

FAA approval has been obtained for technical data in this publication that affects STC or TSO design compliance.

#### EFFECTIVITY:

This service letter applies to Air Tractor models AT-802 and AT-802A with Wipline 10000 Amphibian Floats installed per STC SA01795CH prior to 2/21/2019.

**Note:** Installation of the fill system using Wipaire drawing 7D1-4259, revision J, dated 6/1/2022 already incorporates the intent of this service letter with the strap option.

#### COMPLIANCE:

Optional compliance

#### BACKGROUND:

Due to the high flow rate in the fill system, it is possible for the fill valves to become dislodged from the fill tubes. This service letter provides options to hold the valve in place. The strap option is preferred as the safety wire will not stop the valve from coming off the tube, but it will reduce the loss of the valve.

#### COMPLIANCE METHOD:

Modify both fill valves/tubes as shown in the Work Instruction section of this service letter.

#### APPROXIMATE SHOP HOURS:

The work instruction for this service letter will take approximately 3 labor hours for the safety wire option or 5 labor hours for the strap option.

#### WARRANTY INFORMATION:

This service letter does not include warranty for labor and parts.

1700 Henry Ave - Fleming Field (KSGS), South St. Paul, MN 55075

Phone: 651.451.1205 | Fax: 651.457.7858

www.wipaire.com

**TECHNICAL DATA:**

Copies of this service letter, associated service kit (if applicable), float service manual, and float parts manual are available at [www.wipaire.com](http://www.wipaire.com).

## Work Instructions - Option A - Safety Wire Option

1. Gain access to the two fill valves located within the hopper. See figure 1. If opening the fire gate, disarm the system while performing maintenance.
2. Loosen clamps and remove both valves.
3. Add (2) #10 holes to each valve and to each fill tube, one on top and one on bottom as they sit in the aircraft. The result is (8) total holes for the whole aircraft. Place these holes 3" from the edge of the valve/tube.
4. Create studs at these locations using the hardware identified in Figure 1 and Table 1. Seal with Pro-Seal as needed.
5. Reinstall valves and tighten clamps.
6. Attach 0.041" safety wire between the newly created studs in accordance with AC 43.13 (4 total locations). See Figure 1.
7. Reinstall aircraft panels and close fire gate as needed.

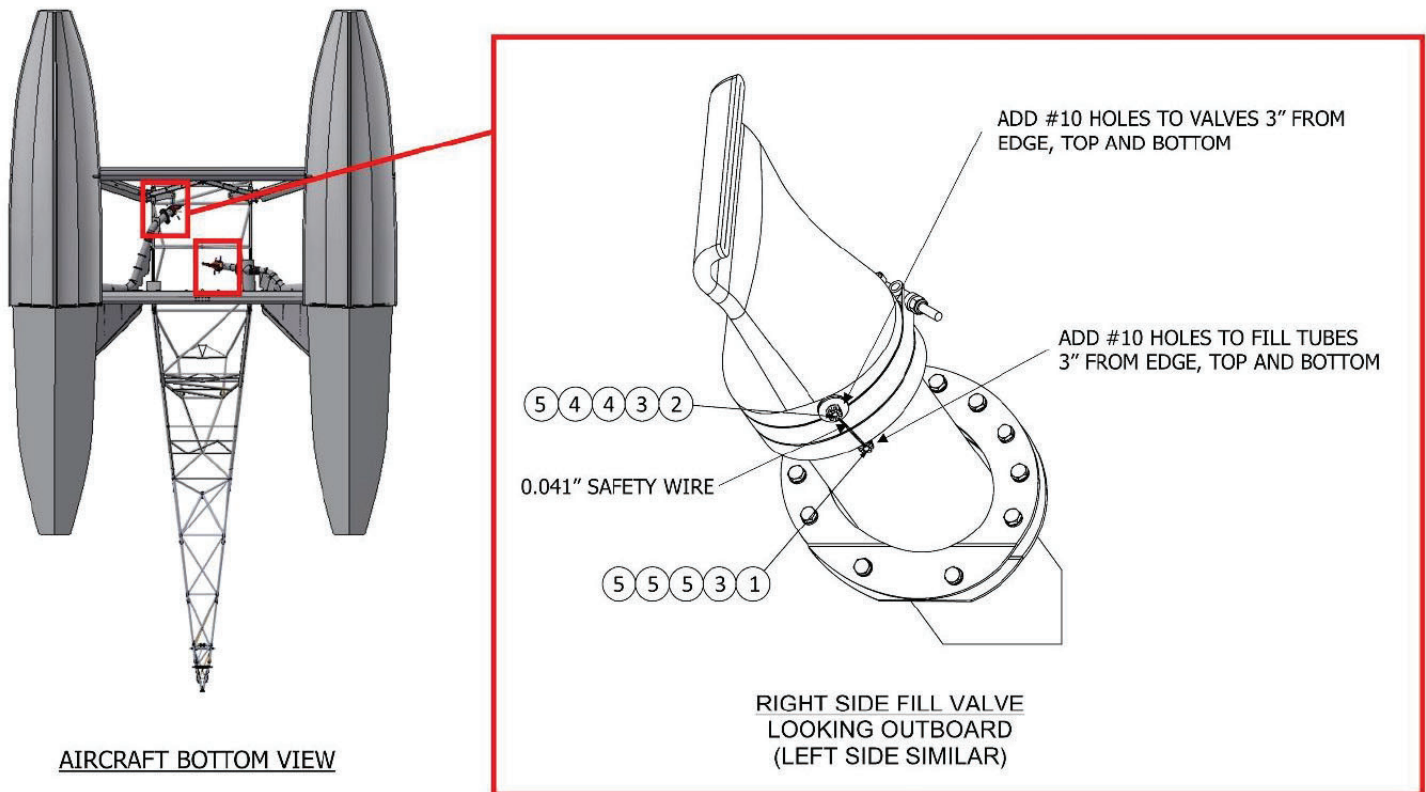

**Figure 1**

ITEM	PART NUMBER	DESCRIPTION
1	AN3C4	BOLT, 10-32, 0.125 GRIP, DRILLED SHANK, SST
2	AN3C7	BOLT, 10-32, 0.5 GRIP, DRILLED SHANK, SST
3	AN310C3	NUT, PLAIN, CASTELLATED, SST, 10-32
4	AN970C3	WASHER, 0.875 OD, 0.203 ID, 0.063 THK, SST
5	NAS1149C0363R	WASHER, 0.203 ID, 0.063 THK, SST

**Table 1**

## Work Instructions - Option B - Strap Option

### Option B-1, Kit 1011930-01: Retrofit straps to existing valve (1 aircraft / 2 valves)

ITEM	QTY	PART NUMBER	Description
1	8	1011964	STRAP, VALVE, SST
2	8	AN526C1032R22	SCREW, 10-32 THREAD, 1-3/8" LENGTH, CORROSION RESISTANT
3	4	AN526C1032R12	SCREW, 10-32 THREAD, 3/4" LENGTH, CORROSION RESISTANT
4	12	AN315C3R	NUT, 10-32, CORROSION RESISTANT
5	12	MS21083C3	NUT, SELF LOCKING, 10-32, CORROSION RESISTANT
6	8	NAS1149C0363R	WASHER, #10, 0.063" THK, CORROSION RESISTANT
7	40	AN970C3	WASHER, #10, LARGE OD, CORROSION RESISTANT

**Table 2**

### Option B-2, Kit 1011930-02: New valve with straps and hardware (1 aircraft / 2 valves)

ITEM	QTY	PART NUMBER	Description
1	2	1012077	ASSEMBLY, VALVE WITH STRAP HARDWARE

**Table 3**

- Gain access to the two fill valves located within the hopper. If opening the fire gate, disarm the system while performing maintenance.
- Loosen clamps and remove both valves.
- (Option B-1)** Add holes as needed to create (4) #10 fastener holes to each valve and (2) #10 fastener holes to each fill tube. Refer to Figure 2 for ideal placement. The result is (12) total holes for the entire aircraft.  
**(Option B-2)** Add (2) #10 fastener holes to each fill tube if none are already present. Replacement valve kit will have holes and studs pre-placed in the valve. Refer to Figure 2.
- Create "studs" as needed at these locations using the hardware identified in Figure 3 and Tables 2 or 3. Except for the pre-assembled studs in replacement valve assembly 1012077 (Option B-2), any existing studs will be made from different hardware which will need to be replaced. Add Pro-Seal to underside of the washers that contact the ID and OD surfaces of the valves and tubes. Hold in place with intermediate nut (item 4). The final two washers and nyloc nut for each stud will be installed during final placement of the straps (step 8).
- (Re)install valves and tighten clamps. The valve studs will need to be within ~6" of the tube studs in order to install straps, but maximum engagement is the goal.
- Temporarily install one end of each strap to determine the placement of the second hole. Bend the straps as needed to take the most direct path, but avoid "cutting" into the valve surface.
- Remove straps from aircraft and add a #10 hole to each strap at the location identified in step 6. Maintain minimum edge distance.
- Install straps and remaining hardware. Refer to Figure 3 and Tables 2 or 3. Excess strap length may be bent out of the way or cut. Smooth any sharp edges.
- Reinstall aircraft panels and close fire gate as needed.

One side of one valve/tube shown. Duplicate on opposite side.

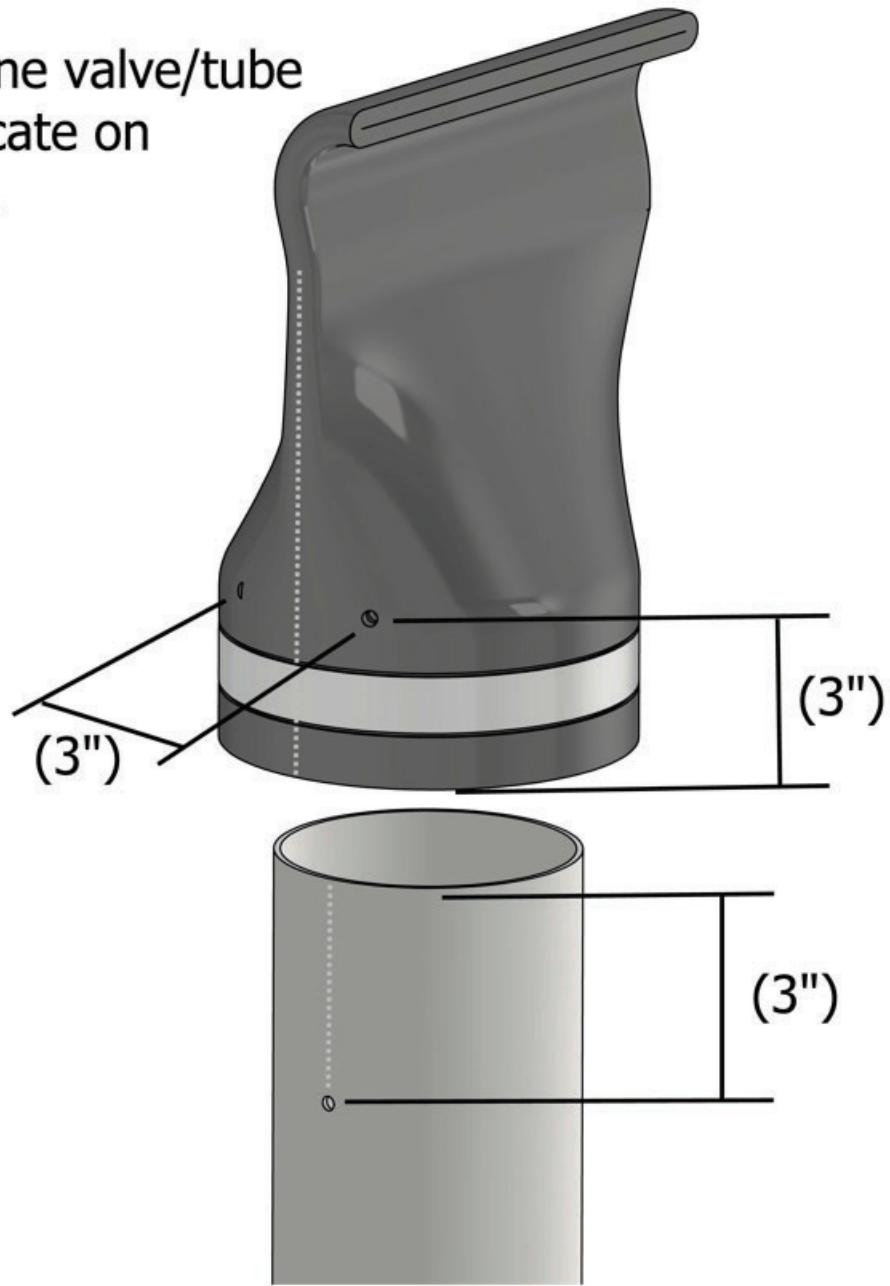

Figure 2

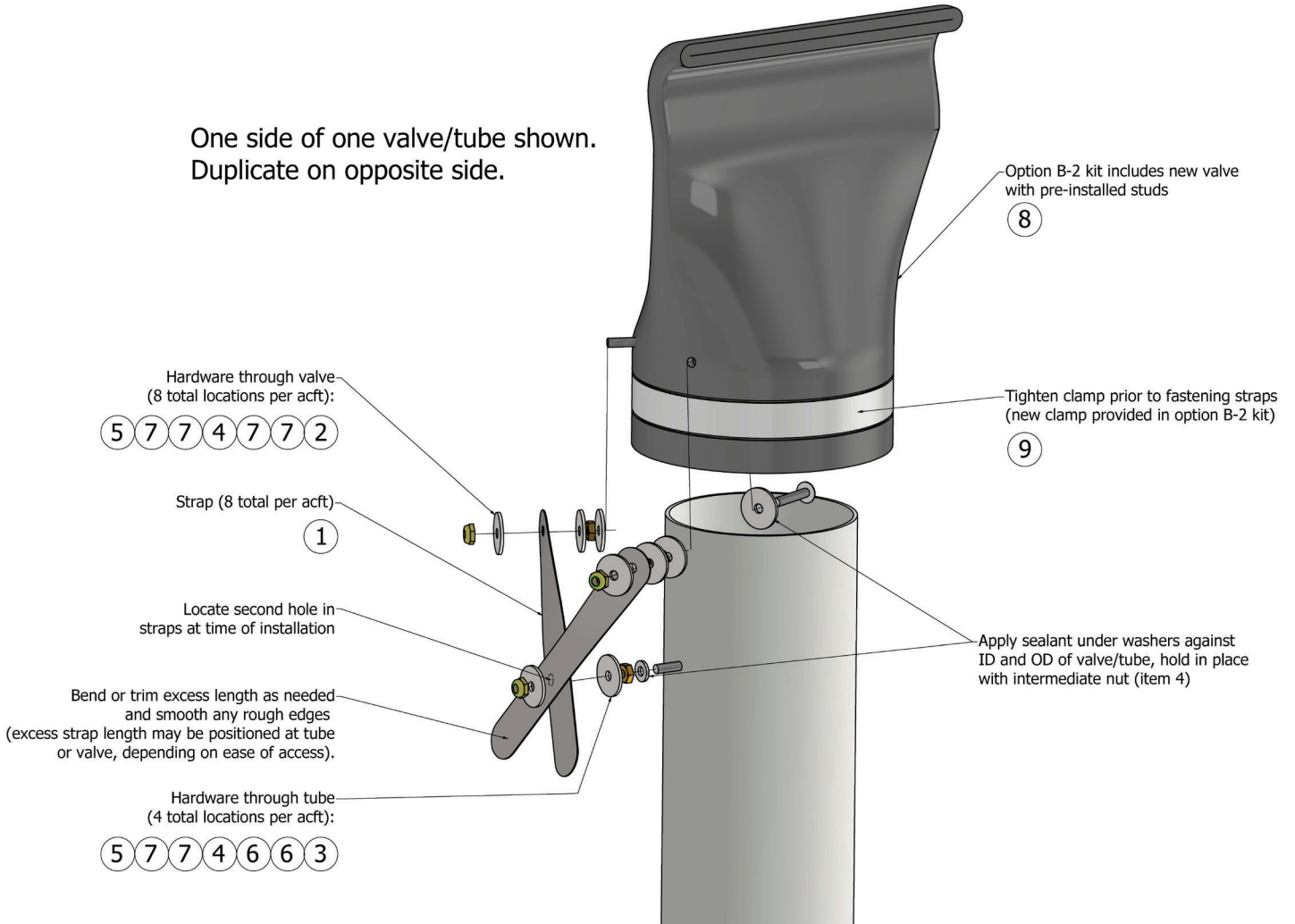

Figure 3

**Items included in 1012077 Assembly, Valve with Strap Hardware**

ITEM	PART NUMBER	Description
1	1011964	STRAP, VALVE, SST
2	AN526C1032R22	SCREW, 10-32 THREAD, 1-3/8" LENGTH, CORROSION RESISTANT
3	AN526C1032R12	SCREW, 10-32 THREAD, 3/4" LENGTH, CORROSION RESISTANT
4	AN315C3R	NUT, THREAD 10-32, CORROSION RESISTANT STEEL, RIGHT-HAND
5	MS21083C3	NUT, SELF LOCKING, 10/32, CORROSION RESISTANT
6	NAS1149C0363R	WASHER, CORROSION RESISTANT, TO FIT DIA #10"
7	AN970C3	WASHER, LARGE AREA FLAT, SIZE #10, STAINLESS STEEL
8	1012076	VALVE, 4" I.D., CURLED
9	5312K17	HOSE CLAMP, 5" DIA

Table 4

**Aircraft Closing & Return to Service**

1. Upon completion of inspection, enter information in Aircraft Logbook for completion of Wipaire Service Letter 235.