



WIPLINE FLOATS • SKIS • MODIFICATIONS • AIRCRAFT SALES  
AVIONICS • INTERIOR • MAINTENANCE • PAINT REFINISHING

## SERVICE LETTER 240

### INSTALL TOP DECK PUMP OUT CUP DUCKBILL VALVE

<b>Aircraft Makes/Model(s):</b>	<b>Float Model(s):</b>	<b>Compliance:</b> Optional	<b>By:</b> MAS
All Aircraft	All Float Models	<b>Part Number:</b> 1011979	<b>Approved:</b> DRH
		<b>Date:</b> 1/30/2023	<b>Revision:</b> C

#### LOG OF REVISIONS

Revision	Description	Date
A	Initial release	10/8/2021
B	Removed and obsoleted Kit 1011979-01. Updated items list and added 1011075.	7/1/2022
C	Added duckbill valve retention measures. Updated effectivity, background, compliance method. Added optional parts list. Updated work instructions and added Figure 2.	1/30/2023

FAA approval has been obtained for technical data in this publication that affects STC or TSO design compliance.

#### EFFECTIVITY:

All floats. Those with pump out plugs p/n 2111 currently installed may use this service letter for retrofit. Those with the newer duckbill design already installed may wish to implement the retention methods described in step 2 of the work instructions.

#### COMPLIANCE:

Optional, the new valve assembly is fully interchangeable with the current plug.

#### BACKGROUND:

Pump out plugs p/n 2111 do not always stay lodged in the cup. A new design includes a retainer that is installed in the cup with clear RTV adhesive (or equivalent) and a rubber, replaceable "Duckbill" valve. This will also allow pumping out water from the float without pulling the plug. See Figure 1 at the end of this service letter. This letter also describes optional methods for increasing retention of the rubber duckbill component, which can be especially useful when exposed to contaminating fluids or prying wildlife.

#### COMPLIANCE METHOD:

Install retainer / valve in as many top deck pump out cups as desired. A uniform configuration across the float set is recommended.

#### APPROXIMATE SHOP HOURS:

Varies per float model. Estimate 5 minutes per pump out cup / plug.

#### WARRANTY INFORMATION:

This service letter does not include warranty for labor and parts.

#### TECHNICAL DATA:

Copies of this service letter, associated service kit (if applicable), float service manual, and float parts manual are available at [www.wipaire.com](http://www.wipaire.com).

1700 Henry Ave - Fleming Field (KSGS), South St. Paul, MN 55075

Phone: 651.451.1205 | Fax: 651.457.7858

[www.wipaire.com](http://www.wipaire.com)

**ORDER ITEMS AS NEEDED (QUANTITY IS PER PUMP OUT CUP)**

ITEM	QTY	PART NUMBER	DESCRIPTION
1*	A/R	1011075	ASSEMBLY, PUMPOUT PLUG, DUCKBILL
2	1	1011808	RETAINER, DUCKBILL VALVE – PUMPOUT PLUG
3	1	1011870	DUCKBILL VALVE – PUMPOUT PLUG
4	A/R	N/A	SILICONE RTV, CLEAR ADHESIVE (OR EQUIVALENT)

\* Items 2 and 3 are included in 1011075 Assembly, Pumpout Plug, Duckbill.

**OPTIONAL ITEMS FOR DUCKBILL VALVE RETENTION (QUANTITY IS PER PUMP OUT CUP)**

ITEM	QTY	PART NUMBER	DESCRIPTION
1	1*	91590A129	SNAP RING, STAINLESS, 13/16" OD (PACK OF 5)
-	1*	97633A260	SNAP RING, BLACK PHOSPHATE, 13/16" OD (PACK OF 50)
2	A/R	N/A	SILICONE RTV, CLEAR ADHESIVE (OR EQUIVALENT)

\* Snap rings are sold in the quantities noted in the item description



**Previous Pump Out Plug**

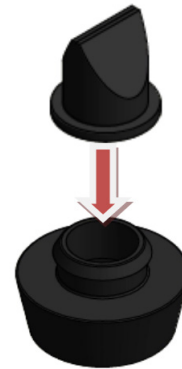

**New 1011075  
Assembly, Pumpout Plug, Duckbill**

## Work Instructions

1. For each pump out cup:
  - a. Remove the current plug
  - b. Clean the cup from dirt and debris. Use IPA or proper cleaner as prep for adhesive.
  - c. Using clear RTV or equivalent (any color can be used), install the retainer in the cup.
  - d. After adhesive has cured, install the duckbill valve onto the retainer.
2. (OPTIONAL) Additional measures for retention of duckbill valve (see Figure 2):
  - a. Using snap ring pliers, install snap ring (see table for p/n) so that it is seated against the upper surface of the duckbill valve flange but below the barb of the retainer, or:
  - b. Clean the mating surfaces and apply RTV below/around the duckbill valve flange where it meets the retainer. Beginning with a few light dabs is recommended, increasing as required.

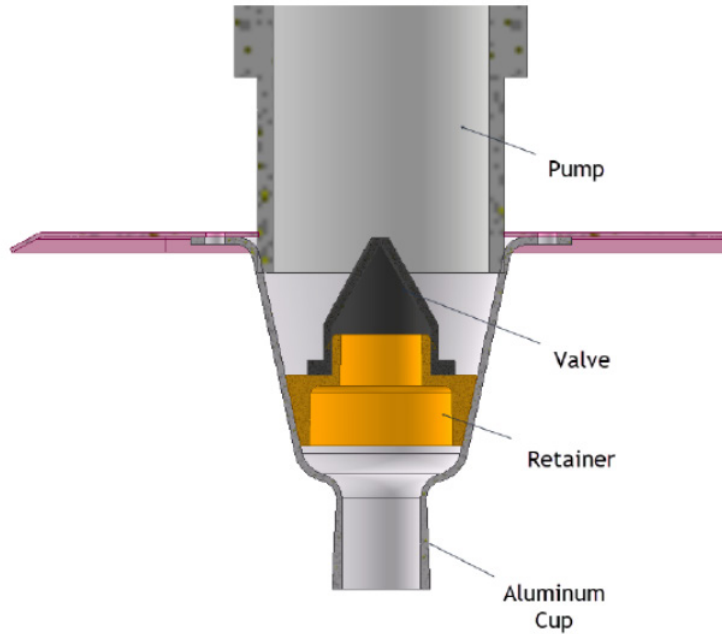

**Figure 1 – New Pump Out Setup**

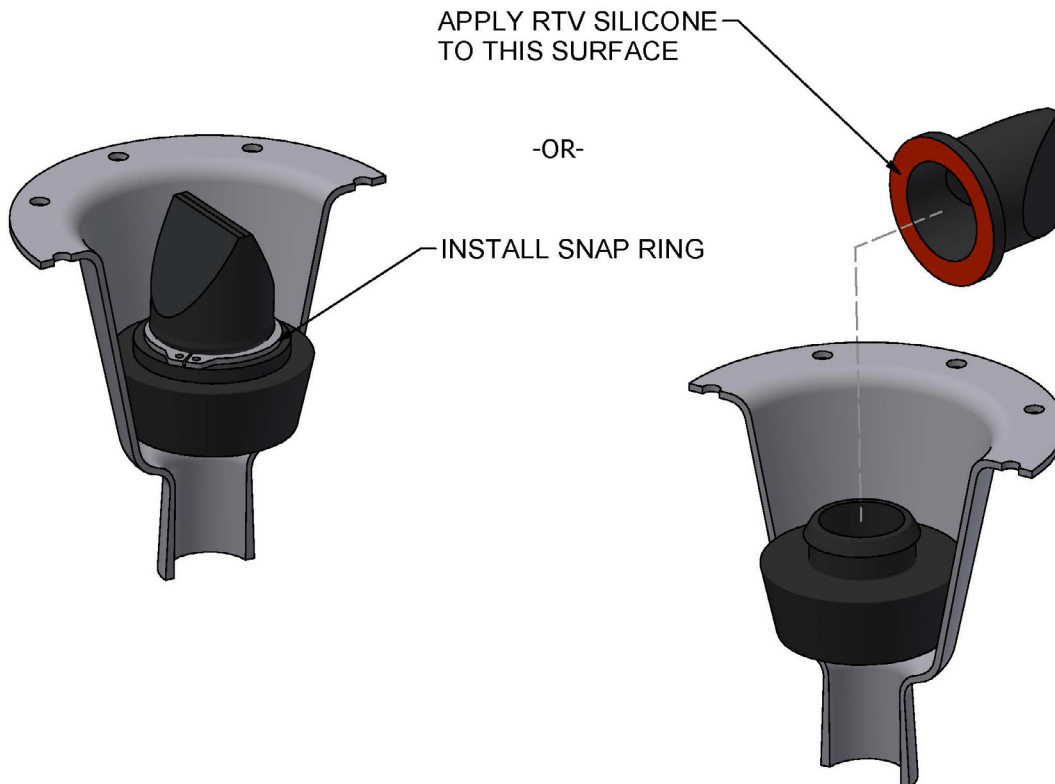

**Figure 2 – Optional Retention Measures**

### **Aircraft Closing & Return to Service**

1. Upon completion of inspection, enter information in Aircraft Logbook for completion of Wipaire Service Letter 240.