



WIPLINE FLOATS • SKIS • MODIFICATIONS • AIRCRAFT SALES
AVIONICS • INTERIOR • MAINTENANCE • PAINT REFINISHING

SERVICE LETTER 253

Horizontal Stabilizer Spar Cracking At Finlets

Aircraft Makes/Model(s):	Float Model(s):	Compliance: Mandatory	By: MAS
Air Tractor AT-802 & AT-802A	10000A	Part Number: 1012347	Approved: DRH
		Date: 3/5/2025	Revision: E

LOG OF REVISIONS

Revision	Description	Date
A	Initial release	4/5/2023
B	Changes made in conjunction per request from FAA. Added finlet configuration basis for initial inspection and adjusted compliance windows. Adjusted recurring inspection interval. Reworded background and compliance method. Added Figure 1 and renumbered following figures. Made LH inspection mandatory regardless of findings on RH (step 9). Added reporting step to Aircraft Closing and Return to Service section.	7/27/2023
C	Rewrite to incorporate bathtub fitting modification, alternate inspection method and interval, added kit 1012347-02.	5/31/2024
D	Full rewrite. Adjusted inspection intervals and removed provisions for the use of previously modified spars, following FAA feedback. Removed lockwasher from retrofit kits and instructions. Adjusted kit tables.	7/3/2024
E	Removed finlet mount gusset requirement. Clarified Work Instructions. Changed quantity of item 33 in kit 1012347-01. Updated Figure 8.	3/5/2025

EFFECTIVITY:

This service letter applies to Air Tractor models AT-802 and AT-802A with Wipline 10000 Amphibian Floats installed per STC SA01795CH with approved finlet configurations as specified in the STC. This service letter also applies to previously floated aircraft that have been converted to landplane configuration under the same STC.

COMPLIANCE:

Compliance is mandatory with initial inspection window and recurring inspection intervals based on finlet configuration and spar reinforcement method. Refer to Figure 1 and the tables within the Compliance Method section. Inspection and retrofit procedures are described in the various "work instruction" sections of this service letter.

NOTE: FAA Airworthiness Directive 2024-16-06 references revision D of this service letter as a means of compliance. Substantively, revision E (this document) is identical to the earlier document with the exception of the finlet mount gusset requirement – an allowance already given by the Airworthiness Directive. This revision may therefore be used as a means of compliance with the AD. Future revisions may revisit this topic. Contact the FAA POC provided in the AD if further clarification is required.

BACKGROUND:

Instances of cracked horizontal stabilizer spars have been observed, primarily on the forward spars near the finlet mounting locations, at/near the spar bend radii. The installation method has since been changed. This service letter supports a phase-out of the prior method while also describing the retrofit process and its altered, ongoing maintenance requirements.

1700 Henry Ave - Fleming Field (KSGS), South St. Paul, MN 55075

Phone: 651.451.1205 | Fax: 651.457.7858

www.wipaire.com

COMPLIANCE METHOD:

Inspect the finlet mount areas as outlined in work instructions, according to installation method and following the intervals laid out below. Photos of characteristic cracks are included in this Service Letter. Any cracks discovered in this area of the horizontal stabilizer spar necessitate replacement of spar. Forward spars also have a limited life, regardless of condition, which is likewise dependent on installation method.

The procedure for replacing Air Tractor spar assemblies is beyond the scope of this service letter. Forward spars are however included with the associated service letter kit (1012347-01) and may be ordered individually through Wipaire or local Air Tractor dealer.

Aircraft not already conforming to the newer "bathtub fitting" method are to be retrofit, as required by the limits shown above (or earlier). Work instructions for retrofit are included in this service letter.

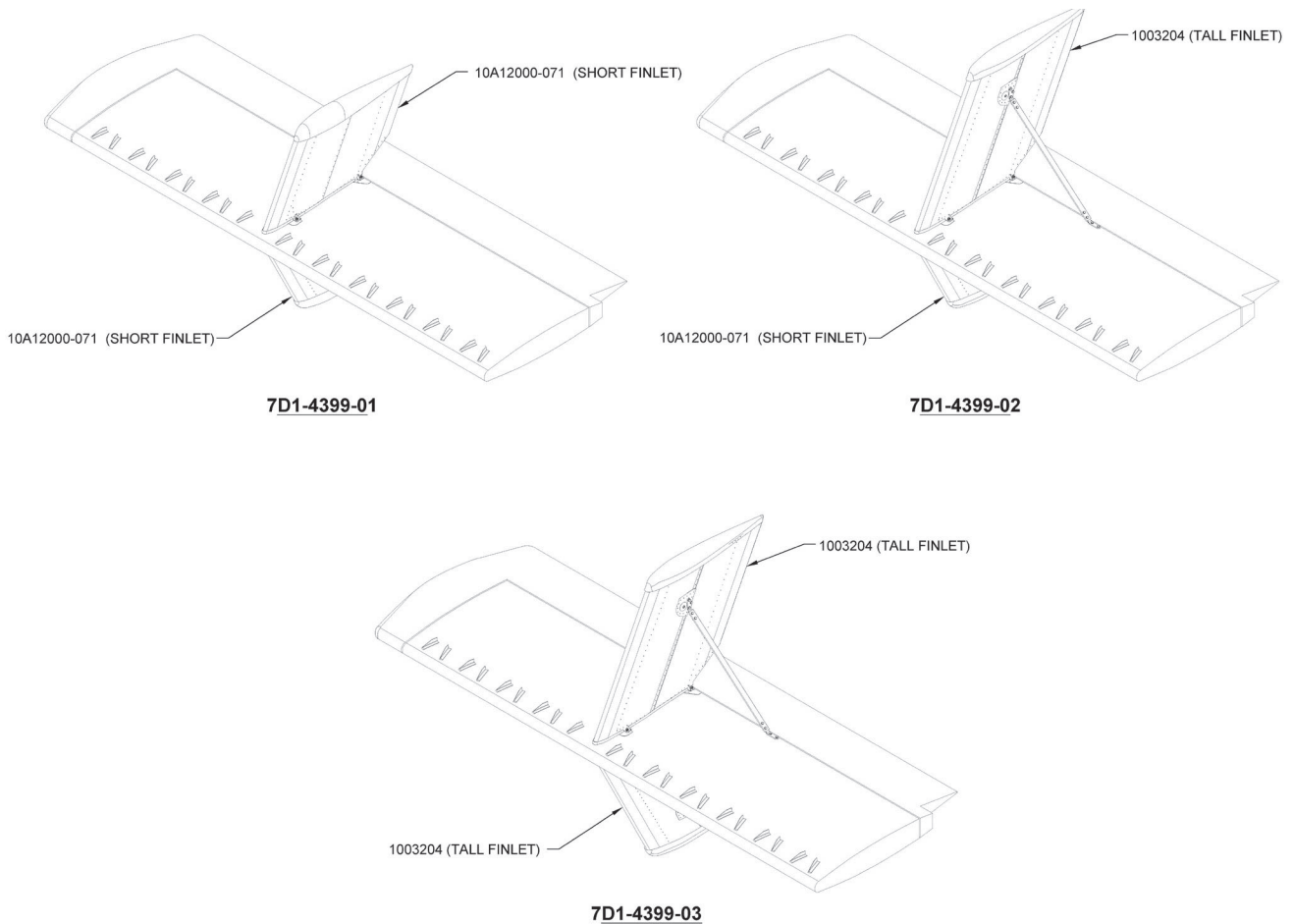

Figure 1
Finlet Configurations (RH Stabilizer Shown)



Method 1 – Applies to installations in accordance 7D1-4399 Revision L or earlier (prior to bathtub fittings), with inspection resulting in one of the following:

- No cracks found, no further action taken, **OR**
- All cracked horizontal stabilizer spars replaced and finlets reinstalled IAW 7D1-4399 Revision L or earlier (prior to bathtub fittings)

Finlet Configuration	Initial Inspection Window*	Recurring Inspection and continuing maintenance, Method 1 (no bathtub fittings)
7D1-4399-01 (short/short)	3 days or 24 hours TIS or before the accumulation of 200 hours TIS since the installation of the STC, whichever occurs later.	<p>110-hour TIS intervals: Remove finlets and inspect spars, replacing spar(s) if damage discovered. Prior to July 31, 2024, this inspection may be accomplished in 200-hour TIS intervals.</p> <p>300 hours TIS from issuance of Service Letter 253 revision D or within 1 year, whichever occurs first: MUST install bathtub fittings (Method 2) regardless of condition.</p>
7D1-4399-02 (tall/short)	5 days or 24 hours TIS or before the accumulation of 300 hours TIS since the installation of the STC, whichever occurs later.	
7D1-4399-03 (tall/tall)	15 days or 24 hours TIS or before the accumulation of 600 hours TIS since the installation of the STC, whichever occurs later.	
Previously floated aircraft now in landplane configuration IAW Wipaire drawing 1003406 (AT-802) or 7D1-4405 (AT-802A)	Same as 7D1-4399-01. See above.	

* Prior compliance with revision A or B of this service letter satisfies the initial inspection requirement; note that revision A only required inspection for the right hand stabilizer. Initial inspection of the left-hand stabilizer is required if not previously accomplished. Replacement of the spar due to the cracking associated with this letter also satisfies the initial inspection requirement for that side of the stabilizer.

Method 2 – Applies to installations conforming to 7D1-4399 Revision M (bathtub fitting update) or later. The following must apply at time of bathtub fitting installation/retrofit:

- Forward spar is to be new (zero-time) if the aircraft has previously accrued time with a finlet installation conforming to 7D1-4399 Revision L or earlier (no bathtub fittings), **OR**
- Forward spar is used but has not been previously modified by STC SA01795CH. The remaining service life of such a spar is 7800 hours less any time accrued prior to modification.

Finlet Configuration	Recurring Inspection and continuing maintenance, Method 2 (bathtub fittings)
All approved finlet configurations shown on install drawing 7D1-4399, as well as previously floated aircraft now in landplane configuration IAW Wipaire drawing 1003406 (AT-802) or 7D1-4405 (AT-802A)	<p>110-hour TIS intervals: Visually inspect spars with bathtub fittings in place.</p> <p>Annual inspection: Perform fittings-in-place visual inspection and retorque fittings and finlet mount bolts.</p> <p>1500-hour TIS intervals: Remove finlets and forward bathtub fittings for spar inspection.</p> <p>7800 hours TIS, including time accrued on spar prior to float modification: Remove fwd spar and fwd bathtub fittings from service and replace with new.</p>

APPROXIMATE SHOP HOURS:

Initial and 110-hour TIS recurring, method 1 - Inspection of spars with finlets installed IAW 7D1-4399 Revision L or earlier (prior to bathtub fittings) will take approximately **10 labor hours** to complete. This inspection requires removal of finlets and this labor estimate includes reinstallation by the same method.

110-hour TIS recurring, method 2 - Visual inspection of spars with bathtub fittings in place will take approximately **3 labor hours** to complete. This inspection does not require removal of finlets.

Annual inspection, method 2 - Inspection of spars and retorque of mount bolts for finlets installed IAW 7D1-4399 Revision M or later (bathtub fittings) will take approximately **4 labor hours** to complete. This inspection does not require removal of finlets or bathtub fittings.

1500-hour TIS recurring, method 2 - Inspection of spars for finlets installed IAW 7D1-4399 Revision M or later (bathtub fittings) will take approximately **14 labor hours** to complete. This inspection requires removal of finlets and bathtub fittings. This labor estimate includes reinstallation by the same method.

Installation (retrofit) of bathtub fittings IAW 7D1-4399 Revision M or later will take approximately **40 labor hours** to complete if reworking horizontal stabilizers (kit 1012347-01), with an additional approximately **40 labor hours** needed for replacement of Air Tractor forward horizontal stabilizer spars, when necessary (approximately **80 hours total**). Alternatively, replacement of complete horizontal stabilizers with built-up Wipaire assemblies will take approximately **20 labor hours** (kit 1012347-02).

WARRANTY INFORMATION:

Warranty coverage is provided for all parts and tooling kits in this service letter for the associated bathtub fitting retrofit. Labor to install bathtub fittings is covered for customers with existing 1-year warranty.

TECHNICAL DATA:

Copies of this service letter, associated service kit (if applicable), float service manual, and float parts manual are available at www.wipaire.com or by contacting Wipaire customer service at customerservice@wipaire.com.

Work Instructions – Inspection, Method 1

(FINLETS INSTALLED WITHOUT BATHTUB FITTING UPDATE – INITIAL AND 110-HOUR RECURRING)

1. Position and prepare aircraft for safe maintenance.

Refer to Figure 2 for steps 2 and 3.

2. Remove upper and lower finlets from left or right horizontal stabilizer.

3. Remove the inspection access cover from the bottom of the right horizontal stabilizer.

Note: Finlet sizes/configurations and the presence of the finlet stabilizing struts will vary with the model and horsepower of the aircraft.

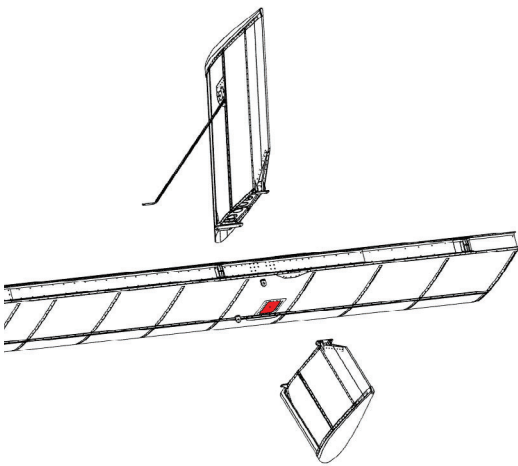

Figure 2

Inspection Access Locations

4. Remove the upper and lower spar strap (10A12001-074) from the forward horizontal stabilizer spar by drilling out the rivets holding it in place. See the parts highlighted in red in Figure 3.

Note: Rivet quantity and type may vary.

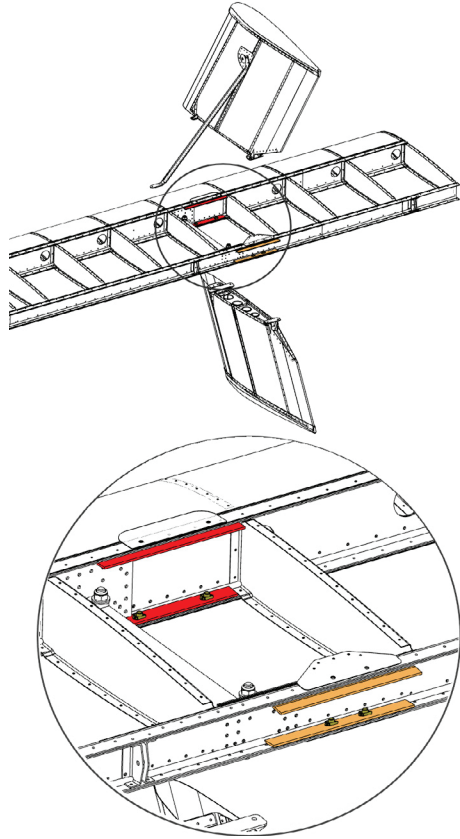

Figure 3

Stabilizer forward spar strap locations (LH stabilizer shown)

5. Clean the area that is to be inspected.
6. Visually inspect for cracks on the forward and aft horizontal stabilizer spars, including both upper and lower flanges and the web area between. Two primary varieties of cracks have been observed. These are described below to aid inspection, but the entire area is to be thoroughly examined:
 - a. A crack originating in the spar web above the forward, outboard mount bolt of the lower finlet. See Figures 4 and 5.
 - b. A crack near the forward, inboard mount bolt, typically within the radius of the spar, and perhaps centered at the corner of the strut brace shim plates. See Figure 6.



Figure 4

Crack above lower finlet forward, outboard mount bolt location (spar strap removed)



Figure 5

Early-stage crack above lower finlet forward, outboard mount bolt location (shown with spar strap in place)

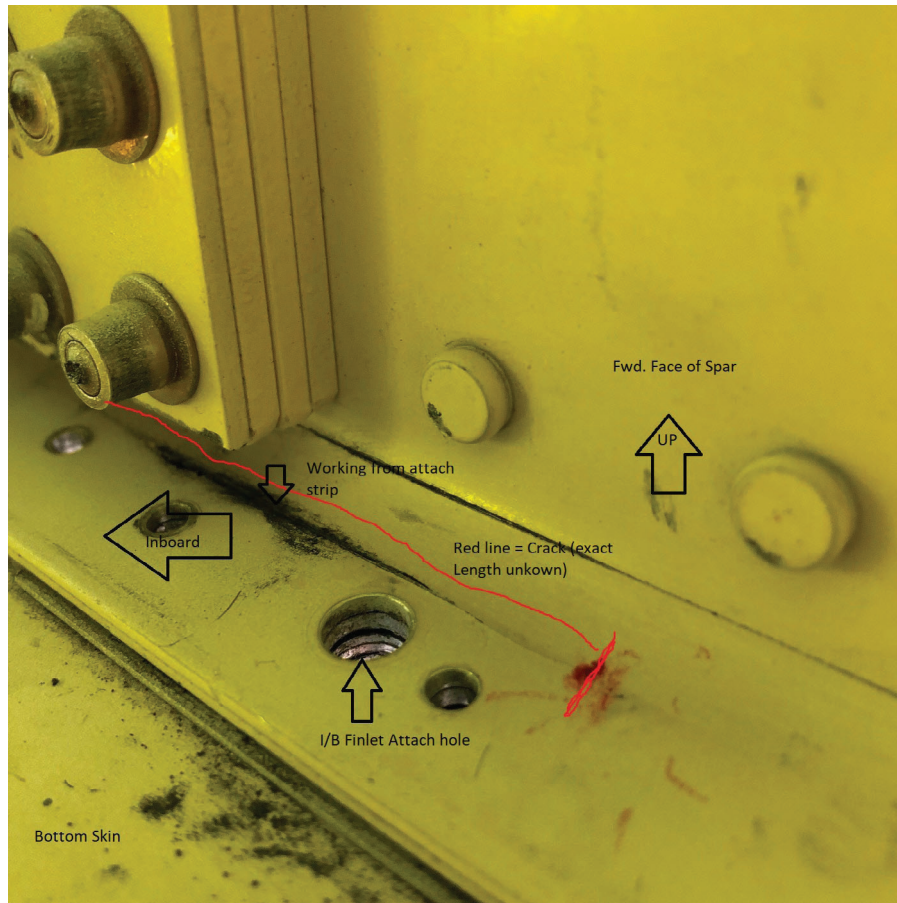

Figure 6

Crack at lower finlet forward, inboard mount bolt location (spar strap removed)

7. If no cracks are present continue to the next step, otherwise:

Any cracks discovered in this area of the horizontal stabilizer spar necessitate replacement of spar; the procedure for replacing the spar is beyond the scope of this service letter. Forward spar assemblies may be ordered directly through Wipaire. See the parts list in the WORK INSTRUCTIONS – INSTALL BATHTUB FITTINGS section.

8. Reinstall finlets following one of the following methods:

- a. It is acceptable to reinstall finlets in the same manner (i.e. without bathtub fittings), but the area will be subject to the method 1 reinspection interval described in the COMPLIANCE section of this service letter. Refer to Wipaire drawing 7D1-4399 revision L for part numbers and proper fitment. Additional notes:
 - i. Apply Loctite 242 or equivalent thread locker (medium strength) to finlet attach bolts.
 - ii. Torque finlet attach bolts 50-70 in-lbs.
 - iii. Apply torque stripes to bolt heads.
- b. Update to bathtub fittings in accordance with Wipaire Drawing 7D1-4399 Revision M or later. This is described in more detail in the WORK INSTRUCTIONS – INSTALL BATHTUB FITTINGS section of this service letter.

Contact Wipaire Customer service at customerservice@wipaire.com or technicalsupport@firebossllc.com to request the appropriate drawing revision.

9. REPEAT THIS INSPECTION FOR THE OPPOSITE HORIZONTAL STABILIZER.

Work Instructions – Inspection, Method 2

(FINLETS INSTALLED WITH BATHTUB FITTINGS - 110-HOUR, ANNUAL, 1500-HOUR)

1. Position and prepare aircraft for safe maintenance.
2. Remove both the leading edge (round) and center (oval) access covers. The leading edge access cover is clipped and can be removed with the lower finlet still in place.

Note: Finlet sizes/configurations and the presence of the finlet stabilizing struts will vary with the model and horsepower of the aircraft.

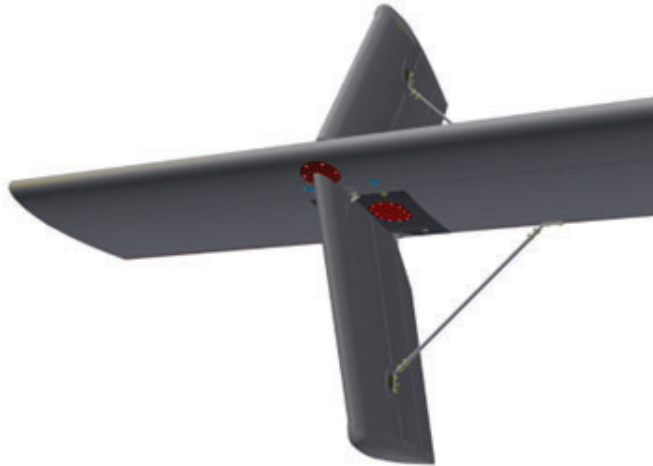

Figure 7
Access Locations

3. 1500 HOUR INSPECTION ONLY – Remove finlets and forward bathtub fittings. Refer to Wipaire Drawing 7D1-4399 Revision M or later while performing the following. Contact Wipaire Customer Service at customerservice@wipaire.com or technicalsupport@firebossllc.com to request the latest drawing revision:

- a. Remove upper and lower finlets from the left or right horizontal stabilizer.
 - b. Remove forward bathtub fittings, PN 1001966. Mark fittings by their location to ensure they are reinstalled in their original positions (step 7).
4. Clean the area that is to be inspected.
 5. Visually inspect for:
 - a. Cracks on the forward and aft horizontal stabilizer spar at finlet attach areas, including both upper and lower flanges and the web area between.
 - b. Cracks emanating from any holes, including those with fasteners installed.
 - c. Cracks on bathtub fittings, especially at holes which may or may not have fasteners installed at time of inspection (forward fittings are removed for 1500hr inspection), and in the radiused corners of these fittings.
 - d. Elongated holes and corrosion in the areas and parts described above.
 6. If no damage is detected continue to the next step, otherwise:

Damage as described above that is discovered in this area of the horizontal stabilizer spar necessitates replacement of spar; the procedure for replacing Air Tractor forward spar assemblies is beyond the scope of this service letter. Forward spar assemblies may be ordered directly through Wipaire or local Air Tractor dealer. See the parts list in the “Work Instructions – Install Bathtub Fittings” section.

Note: New forward bathtub fittings are to be installed with any replaced forward spar, including when spar safe-life is reached.



7. 1500 HOUR INSPECTION ONLY - Reinstall bathtub fittings and finlets. Bathtub fittings are to be reinstalled at their original locations. Refer to Wipaire Drawing 7D1-4399 Revision M (**with special attention to shimming flag note 1.5**) or later and/or pertinent steps within the WORK INSTRUCTIONS – INSTALL BATHTUB FITTINGS section of this service letter. Replace all MS21044N3 nuts (nylon locking) at fittings and MS21042-4 nuts at finlets. Replace bolts on condition. Contact Wipaire Customer service at customerservice@wipaire.com or technicalsupport@firebossllc.com to request the latest drawing revision.

8. ANNUAL INSPECTIONS ONLY – Retorque bathtub fitting bolts through forward spar to 20-25 in-lbs and finlet mount bolts to 50-70 in-lbs.

9. Reinstall access covers

10. REPEAT THIS INSPECTION FOR THE OPPOSITE HORIZONTAL STABILIZER.

Work Instructions – Install Bathtub Fittings

ITEMS PROVIDED IN SERVICE KIT 1012347-01 (1 KIT PER AIRCRAFT)			
ITEM	QTY	PART NUMBER	DESCRIPTION
1	8	1001904	SPACER, BATHTUB
2	12	1001908	SHIM, PEEL AWAY, .094 THICK
3	12	1001909	SHIM, PEEL AWAY, .048 THICK
4	2	1001963	SHIM, FINLET SLOT COVER, AT802/AT802A
5	4	1001966	FITTING, SUPPORT, FINLET, FRONT SPAR (FWD BATHTUB FITTING)
6	4	1001967	FITTING, SUPPORT, FINLET, REAR SPAR (AFT BATHTUB FITTING)
7	2	1001969	RING DOUBLER, ACCESS, LEADING EDGE
8	2	1001979	COVER, ACCESS, SKIN PATCH
9	2	1001978 (ALT FOR 1001971)	SKIN PATCH, SL, AT802 HORIZONTAL, FINLET ATTACH ACCESS
10	2	1001984	ASSEMBLY, RING DOUBLER, BOTTOM SKIN, HORIZONTAL STABILIZER
11	2	1001989	ASSEMBLY, COVER, ACCESS, LEADING EDGE
12	4	10A12005-412	DOUBLER, AFT FINLET ATTACH
13	4	10A12005-413	DOUBLER, FWD FINLET ATTACH
14	6	AN173-6A	BOLT, CLOSE TOL, 10-32, 0.375 GRIP, UNDRILLED, STEEL
15	6	AN173-7A	BOLT, CLOSE TOL, 10-32, 0.5 GRIP, UNDRILLED, STEEL
16	32	AN526-832R6	SCREW, MACHINE, TRUSS HEAD
17	8	CR3213-4-04	RIVET, CHERRY MAX, 1/8
18	8	CR3243-4-04	RIVET, CHERRY MAX, 1/8 OVERSIZE
19	16	MS20002C4	WASHER, HIGH STRENGTH, COUNTERSINK, 1/4
20	16	MS20426AD3-3-5	RIVET, COUNTERSUNK, 1/8" DIA, 7/32" LENGTH
21	72	MS20470AD3-3-5	RIVET, SOLID, UNIVERSAL, 3/32" DIA, 7/32" LENGTH
22	104	MS20470AD4-3-5	RIVET, SOLID, UNIVERSAL, 1/8" DIA, 7/32" LENGTH
23	10	MS20470AD4-4	RIVET, SOLID, UNIVERSAL, 1/8" DIA, 1/4" LENGTH
24	8	MS20470AD4-6	RIVET, SOLID, UNIVERSAL, 1/8" DIA, 3/8" LENGTH
25	26	MS20470AD4-7	RIVET, SOLID, UNIVERSAL, 1/8" DIA, 7/16" LENGTH
26	4	MS20470AD4-8	RIVET, SOLID, UNIVERSAL, 1/8" DIA, 1/2" LENGTH
27	12	MS20470AD6-11	RIVET, SOLID, UNIVERSAL, 3/16" DIA, 11/16" LENGTH
28	8	NAS1097AD4-6	RIVET, REDUCED COUNTERSINK, 1/8" DIA, 3/8" LENGTH
29	16	NAS1097AD4-7	RIVET, REDUCED COUNTERSINK, 1/8" DIA, 7/16" LENGTH
30	6	NAS1097AD6-8	RIVET, REDUCED COUNTERSINK, 3/16" DIA, 1/2" LENGTH
31	6	NAS1097AD6-9	RIVET, REDUCED COUNTERSINK, 3/16" DIA, 9/16" LENGTH
32	16	MS21042-4	NUT, SELF LOCKING, 450°, 1/4-28 UNF
33	40	MS21044N3	NUT, LOCKING, REGULAR HEIGHT, 10-32 UNF
34	8	MS21069L08	NUT PLATE, REDUCED RIVET SPACING, 8-32
35	18	NAS1149F0332P	WASHER, 0.203 ID, 0.032 THK, STEEL
36	12	NAS1149F0363P	WASHER, 0.203 ID, 0.063 THK, STEEL
37	16	NAS620-416	WASHER, REDUCED OD, STEEL, 416
38	16	NAS624-10	BOLT, 12 POINT, 1/4-28 UNF, 0.625 GRIP
39	8	NAS624-12	BOLT, 12 POINT, 1/4-28 UNF, 0.750 GRIP
40	1	30662-1	AIR TRACTOR, SPAR ASSY-STAB FRONT, LEFT-SIDE



ITEM	QTY	PART NUMBER	DESCRIPTION
41	1	30662-2	AIR TRACTOR, SPAR ASSY-STAB FRONT, RIGHT-SIDE

ITEMS PROVIDED IN SERVICE KIT 1012347-02 (1 KIT PER AIRCRAFT)			
ITEM	QTY	PART NUMBER	DESCRIPTION
1	1	1001998-01	ASSEMBLY, HORIZONTAL STABILIZER, LEFT, FLOATPLANE, AT802/AT802A
2	1	1001998-02	ASSEMBLY, HORIZONTAL STABILIZER, RIGHT, FLOATPLANE, AT802/AT802A
3	16	MS20002C4	WASHER, HIGH STRENGTH, COUNTERSINK, 1/4
4	16	MS21042-4	NUT, SELF LOCKING, 450°, 1/4-28 UNF
5	16	NAS620-416	WASHER, REDUCED OD, STEEL, 416
6	16	NAS624-10	BOLT, 12 POINT, 1/4-28 UNF, 0.625 GRIP
7	8	NAS624-12	BOLT, 12 POINT, 1/4-28 UNF, 0.750 GRIP

Note: The complete horizontal stabilizer assemblies provided with kit 1012347-02 do not include finlets or vortex generators, and painting may be required.

ADHESIVE SUPPLIES FOR BONDING SHIMS (ORDER AS REQUIRED)			
ITEM	QTY	PART NUMBER	DESCRIPTION
1	AR	7100148731*	DP 420 ADHESIVE, 3M (1 CARTRIDGE COVERS 3 AIRCRAFT)
2	AR	7100148764*	EPX APPLICATOR, 3M
3	AR	7100104991*	MIXING NOZZLE, 3M (NEED 4 PER AIRCRAFT)

* or equivalent

TOOLING LIST (1012347-TK, OR ORDER INDIVIDUALLY AS REQUIRED)			
ITEM	QTY	PART NUMBER	DESCRIPTION
1	1	7D1-4399-T1	TOOLING, DRILL TEMPLATE, ACCESS HOLE, AT802 FINLET ATTACH
2	1	7D1-4399-T2	TOOLING, LEADING EDGE ACCESS CUTOUT
3	1	7D1-4399-T3	TOOLING, BATHTUB FITTING SPACING, FINLET MOUNT
4	1	7D1-4399-T4	TOOLING, DRILL JIG, FINLET MOUNT LOCATION
	1	8493A136*	REMOVABLE DRILL BUSHING, 0.1875" ID, 1/2" OD, 1-3/8" LONG (INCL W/ -T4 TOOL)
	3	8493A235*	REMOVABLE DRILL BUSHING, 0.25" ID, 1/2" OD, 1-3/8" LONG (INCL W/ -T4 TOOL)
	4	8496A13*	LOCK SCREW FOR REMOVABLE DRILL BUSHINGS (INCL W/ -T4 TOOL)
5	1	7D1-4399-T5	TOOLING, HOLE SAW ARBOR, 1/4 IN DRILL BLANK
6	1	4066A61*	HOLE SAW, 1-15/16" CUTTING DEPTH, 4-1/2" DIAMETER
7	1	4066A72*	HOLE SAW, 1-15/16" CUTTING DEPTH, 5" DIAMETER
8	1	74720*	REVERSE COUNTERSINK, 1/8" PILOT X 5/16" DIA, 100DEG
9	1	70151*	REVERSE PILOT, 1/8"
10	2	CL-7-SP*	SHOULDER PIN, 1/4"
11	1	T172-4*	HOLE GAGE, CHERRY RIVET

* or equivalent

Note: Spars modified to 7D1-4399 Revision L or earlier must be replaced with new (zero-time) spars regardless of condition. The procedure for replacing Air Tractor spar assemblies is beyond the scope of this service letter. Forward spars are however included with the associated service letter kit (1012347-01) and may be ordered individually through Wipaire or local Air Tractor dealer.

1. Remove elevator per Air Tractor service documents.
2. Remove finlets. Each finlet is fastened by (4) bolts at the mount weldments. If present, detach strut from horizontal by removing (2) bolts through aft spar. Refer to Figure 8.

NOTE: Prior revision of this service letter required that finlet mounts include gussets near the mount bolts. This is not a requirement of associated FAA Airworthiness Directive 2024-16-06 and is no longer a requirement of this Wipaire service letter.

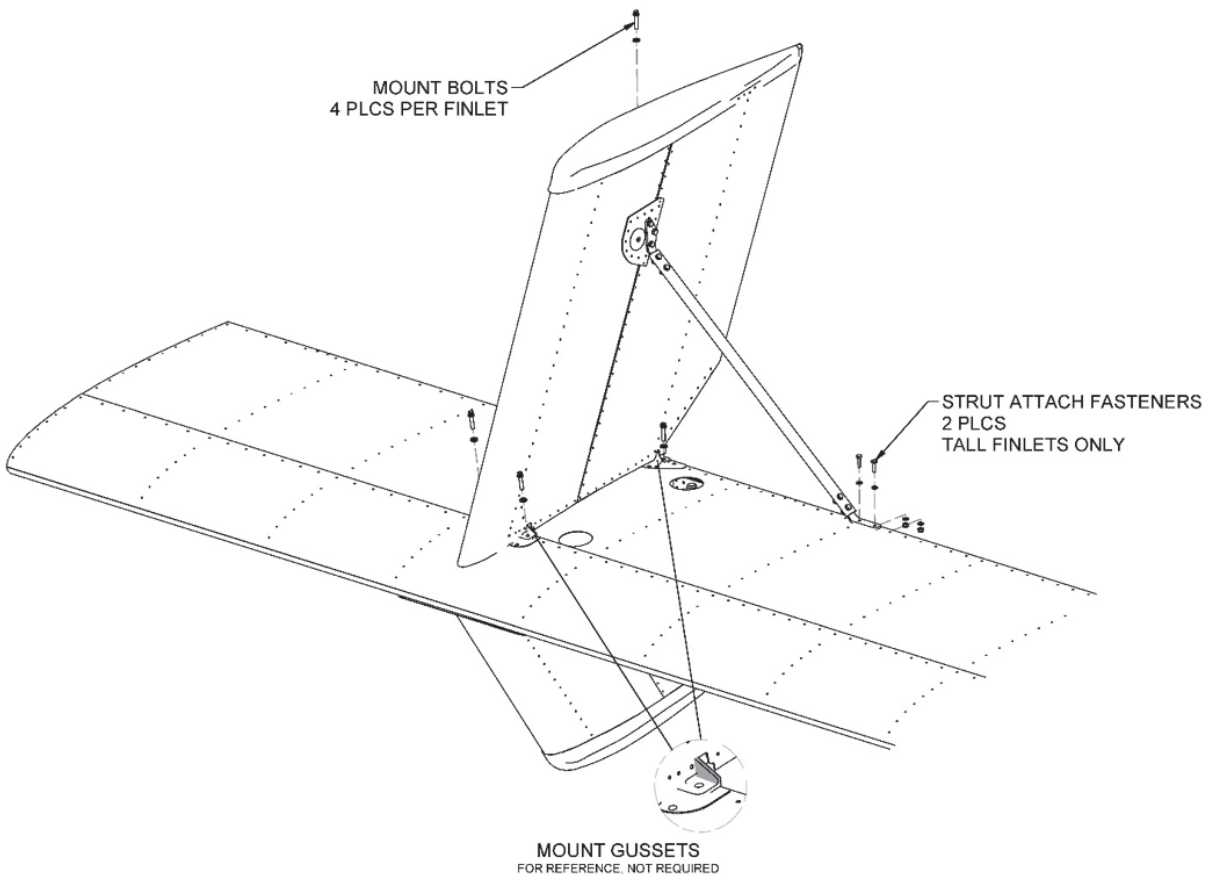

Figure 8
Finlet

3. Remove stabilizer per Air Tractor service documents.
4. If reworking horizontal stabilizers via kit 1012347-01, remove and discard: external doublers, nutplate straps, and internal Air Tractor doubler 30667-1 .
5. Refer to Wipaire installation drawing 7D1-4399 Revision M or later for modification of horizontal stabilizers and installation of bathtub fittings 1009666 and 1009667 (kit 1012347-01). This drawing also describes the alternate use of complete horizontal stabilizers with bathtub fittings pre-installed (kit 1012347-02). Contact Wipaire Customer Service at customerservice@wipaire.com or technicalsupport@firebossllc.com to request the latest drawing revision.

Note: Service Letter kit utilizes an alternate skin patch to accommodate prior modification of stabilizer skin. (1001978 in place of 1001971)

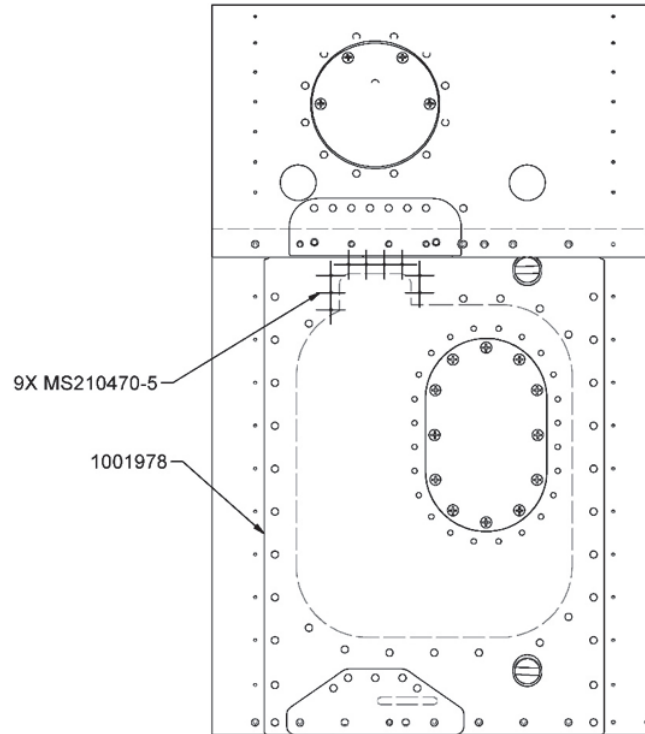

Figure 9
Alternate Skin Patch

6. Install stabilizer per Air Tractor service documents.
7. Install finlets. Refer to installation drawing 7D1-4399 Revision M or later.
8. Install finlet struts. Refer to installation drawing 7D1-4399 Revision M or later.
9. Install access covers. Refer to installation drawing 7D1-4399 Revision M or later.
10. Install elevator per Air Tractor service documents.

Aircraft Closing & Return to Service

1. Upon completion of inspection, enter information in Aircraft Logbook for completion of Wipaire Service Letter 253 **Revision D**, and note observations.
2. Report ALL inspections to Wipaire regardless of whether or not cracks were revealed. Include the following information:
 - Hours since initial modifications associated with STC SA01795CH occurred
 - Model/engine configuration (with HP limits)
 - Propeller type
 - Finlet configuration (7D1-4399-01, 7D1-4399-02, 7D1-4399-03, landplane)
 - Spar reinforcement method: 7D1-4399 Rev L or prior (no bathtub fittings) - vs.- 7D1-4399 Rev M or later (bathtub fittings)
 - Hours on bathtub fittings, if installed
 - Crack location(s), if applicable (RH/LH, upper/lower spar flange, inboard/outboard finlet mount hole, etc.)
 - Crack size(s), if applicable
 - Photos of crack(s), if found
 - Registration number
 - Serial number
 - Total hours on airframe
 - Operator comments